

SPECIFICATIONS, SPECIAL PROVISIONS AND CONTRACT DOCUMENTS

**CITY OF MIDWEST CITY
100 N MIDWEST BLVD
REPLACEMENT OF AHU 6&8**



Matt Dukes, MAYOR

CITY COUNCIL MEMBERS

WARD 1 – Susan Eads

WARD 4 – Sean Reed

WARD 2 – Pat Byrne

WARD 5 – Sara Bana

WARD 3 – Rick Dawkins

WARD 6 – Rick Favors

**Tim Lyon
CITY MANAGER**

**Brandon Bundy
ENG & CONST SERV DIRECTOR**

**Sara Hancock
CITY CLERK**

**Donald Maisch
CITY ATTORNEY**

Prepared by:
The City of Midwest City
100 North Midwest Boulevard
Midwest City, Oklahoma 73110
(405) 739-1220

THESE SPECIFICATIONS MUST BE READ AND CONSTRUED AS A WHOLE

TABLE OF CONTENTS

Table of Contents..... TC-1
Notice to Bidders.....NTB-1
General Information for BiddersGIB-1

SECTION A - SPECIAL PROVISIONS..... A-1
SECTION B - GENERAL CONDITIONS..... B-1
SECTION C - CONSTRUCTION SPECIFICATIONS..... C-1

Contract CT-1
Statutory Bond SB-1
Performance Bond PB-1
Maintenance Bond MB-1
Bid BID-1
Detailed Bid FormDBF-1
Noncollusion Affidavit NA-1
Certification of Pre-Bid Site Inspection CSI-1
Bid Bond BB-1
Business Relationships Affidavit..... BRA-1
Bid Affidavit BA-1
Contactor Certification CC-1
Statement of Bidder’s Qualifications SBQ-1

APPENDIX:
 Example Bid Form

NOTICE TO BIDDERS

Notice is given that the City of Midwest City will receive sealed bids in the Office of the City Clerk, Midwest City Municipal Center, 100 N. Midwest Blvd., Midwest City, Oklahoma, until **2:00 pm on May 14, 2024** for:

REPLACEMENT OF AHU 6 AND 8

Bids received more than ninety six (96) hours, excluding Saturdays, Sundays and holidays, before the time set for opening of bids, as well as bids received after the time set for opening of bids, shall not be considered and shall be returned unopened. Bids shall be made in accordance with the bid documents, all of which are on file and available for public examination at the Office of the City Clerk in the Midwest City Municipal Center at the address listed above.

Complete sets of general conditions, plans, specifications, and other bidding documents MAY be obtained from the City of Midwest City. Please contact Engineering and Construction Services Department, at 100 North Midwest Boulevard, Midwest City, Oklahoma 73110. Telephone (405) 739-1220.

The cost of the PRINTED plans and specifications will be Thirty Dollars and no Cents (\$30.00) per set. ELECTRONIC plans and specifications will be Thirty Dollars and no Cents (\$30.00). Purchases are non-refundable.

Bids filed with the City Clerk shall be opened publicly and read aloud in the City Council Chambers at the time stated above or later. The Mayor and Council shall consider all bids prior to the award of the contract. The City Council may consider award of the bid at or after **6:00 pm on May 28, 2024** to the lowest and best bidder meeting specifications. The City Council may lay the same over to a subsequent meeting for comparison and computation.

Sales Tax Exemption. Title 68, Oklahoma Statutes (1991), Section 1356(1), exempts sales to municipalities and their contractors from sales taxes on the sale of "tangible personal property or services." All bids for City projects shall be assumed to have been made based on such statutory exemption as effective on the bid date.

The bidder shall use the City's bid forms and affidavits, and all forms shall be signed and notarized/attested. The bidder shall file the bid in a sealed envelope. The envelope shall bear a legible notation thereon stating that it is a bid for the project proposed. The bid shall be filed with the City Clerk in the City Clerk's office. All bids shall be typewritten or in ink.

The bidder must attend the mandatory pre-bid conference at **2:00 pm on April 30, 2024** in the Council Chambers of the Midwest City Municipal Center, 100 N. Midwest Boulevard, Midwest City, Oklahoma. The meeting will be followed by a trip to the project site. **Attendance and project site inspection is required in order to be qualified to submit a bid.** Refer to the Certification of Pre-Bid Site Inspection form, CSI-1, for additional information.

The specifications are complete as written. No oral representations made by any agent or employee of the City or its affiliate agencies shall be of any force or effect unless reduced to writing and submitted to all prospective bidders at least 24 hours in advance of the bid opening.

Any protest of the award of this proposed contract shall be in writing, shall specify the grounds for the protest in specific terms and shall be received by the City Clerk within three (3) business days after the award of the contract by the governing body. The governing body reserves the right to review all bids and make the award to the lowest and best bidder. All other provisions of the specifications shall also apply.

The following documents comprise the complete bid package and must be submitted. Incomplete bid packages may be rejected.

1. Midwest City standard bid bond or surety bid bond form or cashier's check in the amount of five (5) percent of the total bid (cashier's checks will be returned to the unsuccessful bidders following the acceptance of the bid).
2. Bid.
3. Certification of Pre-bid Site Inspection.
4. Statement of Bidder's Qualifications.
5. Business Relationships Affidavit.
6. Bid Affidavit.
7. Non-Collusion Affidavit.
8. All Addendum Acknowledgment(s) (if applicable).
9. Contractor Certification

Additional information may be obtained by contacting the Midwest City Engineering and Construction Services Department at (405) 739-1220.

The Midwest City Council reserves the right to reject any or all bids.

Note: Failure to comply with any of the 9 listed items may disqualify the Bidder's Submittal.



SARA HANCOCK
CITY CLERK

GENERAL INFORMATION FOR BIDDERS

The City of Midwest City requires the execution and submittal of specific bid documents with each bid for a city, authority or grants project, and mandatory attendance at the prebid meeting. The following sections briefly outline the city's project bidding practices and procedures.

BID PACKAGES

Each and every required bid document must be submitted with the bid and must be signed in ink by the person with the authority to so execute the document and must be properly attested to or witnessed. The documents required vary with the type and nature of the work and the required bid documents are always listed on the Notice to Bidders provided at the beginning of every specification book. The bid documents required for most projects are as follows:

- a. Bid bond or cashier's check in the amount of five (5) percent of the total bid
- b. Bid
- c. Certification of Pre-Bid Site Inspection
- d. Statement of Bidder's Qualifications
- e. Business Relationships Affidavit
- f. Bid Affidavit
- g. Noncollusion Affidavit
- h. Contractor Certification
- i. Addendum Acknowledgment(s)

The following is a brief synopsis of the bid documents and is provided to assist you in completing the required forms.

1. Bid Bond.

A Midwest City standard bid bond form or surety bid bond form or cashier's check in the amount of five (5) percent of the **total bid** is the required bid security in accordance with the provisions of the Public Competitive Bidding Act of 1974, as amended (61 Okla. Stat. 1991, § 107). A copy of the city standard bid bond form is provided as a part of the bid package and the form may be used in lieu of a bid bond provided by a surety company. The total bid amount that the bond or cashier's check is written for is the largest combination of the base bid plus the alternate bids.

The bid security is a pledge that the bidder will enter into a contract with the city on the terms stated in the bid and will furnish bonds covering the faithful performance of the contract and payment of all obligations. Should the bidder refuse to enter into such contract or fail to furnish the required bonds, insurance certificates and other required documents, the bid security shall be forfeited to the city.

The city bid bond form requires execution by a corporate officer representing the company submitting the bid and the bonding company. The surety company executing the bid bond must be authorized to transact business in the state of Oklahoma.

The city has the right to and does retain the bid securities of all bidders until either (a) the contract, bonds, and other required documents have been executed or submitted by the successful bidder or (b) the specified time to award bids has elapsed so that bids

may be withdrawn in accordance with State law or (c) all bids have been rejected or (d) a bidder has been determined to be the successful bidder.

2. Bid

The bid is a complete and properly signed proposal, to do the work for the sums specified, submitted in accordance with the bid package documents and the contract documents. The “base bid” is the sum stated in the bid for which the bidder offers to perform the work described in the bid package documents as the base to which work may be added or from which work may be deleted for the sums stated in the alternate bid(s).

An “alternate bid (or alternate)” is an amount stated in the bid to be added to or deducted from the amount of the base bid if the corresponding change in the work, as described in the bid package documents, is accepted.

A “unit price” is an amount stated in the bid as a price per unit of measurement for materials, equipment or services, or a portion of the work as described in the bidding documents.

Bids must be submitted on the bid forms provided in the bid package at the prebid meeting or on photocopies of those forms. Bid forms are unique to each project and therefore forms other than those provided cannot and will not be accepted.

All blanks for unit prices with extensions must be completed and the bid must be totaled. The bid form must be executed by a corporate officer representing the company submitting the bid and the form must be attested to by another corporate representative or otherwise duly notarized. All blanks on the bid form must be filled in by typewriter or legibly printed in ink. Where indicated on the bid form, amounts shall be expressed in both words and figures and, in case of any discrepancy between the two, the amount written in words shall govern.

Unless otherwise provided for when unit prices are bid, partial payments and final claims will be based on actual quantities used. Any substantial change(s) in quantities required to complete the work requires a contract amendment which will be based on the unit prices bid.

Erasures and/or corrections must be initialed by the signer of the bid. A bid with erasures and/or corrections that are not initialed shall be considered to be invalid and incomplete.

An example of a properly completed bid form with sample correction is provided in the Appendix of these specifications.

3. Certification of Pre-Bid Site Inspection

The site inspection certification is a standard form that states that the bidder has visited the site and has become familiar with local conditions under which the work is to be performed. It indicates that the bidder has informed himself by independent research of the difficulties to be encountered and has personally judged the accessibility of the work and all attending circumstances affecting the cost of doing the work and of the time required for its completion.

The site inspection certification form requires execution by a corporate officer representing the company submitting the bid.

4. Statement of Bidder's Qualifications

The statement of bidder's qualifications is a standard form that provides the city with background information on the bidder. It is used solely as a matter of information to evaluate a prospective bidder's capacity to execute the contract requirements and to check references. Midwest City does not have a pre-qualification requirement or a contractor licensing requirement; therefore this document is required.

The statement of bidder's qualifications form requires execution by a corporate officer representing the company submitting the bid and must be duly notarized.

5. Business Relationships Affidavit.

6. Bid Affidavit.

7. Noncollusion Affidavit.

The affidavit forms require execution by a corporate officer representing the company submitting the bid and must be duly notarized.

8. Addendum Acknowledgment(s)

Addenda are written or graphic instruments issued prior to the bid date which modify or interpret the bidding documents by additions, deletions, clarifications, or corrections.

The bidding documents represent all the information the city will provide. Interpretations and corrections of and/or changes to the bidding documents will be made only by addendum. Interpretations and/or changes made in any other manner will not be binding upon the city and bidders shall not rely upon them.

Addenda will be mailed, faxed, emailed or delivered only to those bidders who attended and signed the prebid meeting sign in sheet.

The following shall be considered proof that a bidder received an addendum:

- 1) Mailed addendum: The bidder's signature or bidder's representative's signature on the certified mail return receipt.
- 2) Hand delivered or picked-up addendum: The bidder's or bidder's representative's signature on the addendum received signature list.
- 3) Faxed addendum: The city's or the consultant's fax confirmation sheet.
- 4) "By E-mail to an address provided by the bidder and posting on the City's webpage."

It is the responsibility of the bidder to ascertain from the City Clerk's Office, within two working days prior to the bid date, whether the bidder has received all addenda.

An addendum acknowledgment sheet accompanies each and every addendum and must be signed by a corporate officer representing the company submitting the bid. All addendum acknowledgment sheets must be submitted with the bid in order for the bid to be considered.

PREBID MEETING

The **mandatory** prebid meeting notice is included in the published **Notice to Bidders**, which is also provided at the beginning of every specification book. The notice specifies the date, time, and place for the meeting and the bidder must be represented at the meeting in order to be qualified to submit a bid for the project. The meeting is open to all prospective bidders and other interested parties. The consulting architect or consulting engineer and the city engineer or their designees will be present. The purpose of the meeting is to discuss the plans and specifications.

In compliance with the provisions of the Americans with Disabilities Act, a sign language interpreter or any other reasonable accommodation to attend and/or fully participate in the meeting will be provided at the prebid meeting upon twenty-four (24) hours notice to the city engineer.

ACCEPTANCE OF BID AND AWARD OF CONTRACT

It is the intent of the city to award a contract to the lowest and best bidder meeting specifications provided that the bid submitted is in accordance with the requirements of the bidding documents and does not exceed the engineer's estimate or the funds available. The city has the right to waive immaterial defects or irregularities in bids received and to accept the bid which, in the city's judgment, is in its own best interest.

The city has the right to accept alternates in any order or combination, unless otherwise specifically provided in the bidding documents, and to determine the lowest and best bidder on the basis of the sum of the base bid and any alternates accepted.

The city reserves the right to offer the contract to the bidder deemed to be the next lowest and best bidder should the original bidder who is awarded the contract fail to execute and provide the contract and bonds or fail to provide the required certificates of insurance and/or any other required documents.

The city is providing a draft of a contract. It is anticipated that the winning bidder abide by the contract terms stated in the draft contract provided in these documents. It is anticipated that minimal negotiation for a contract will occur. Please read and make sure that you, as bidder, can meet all the terms and conditions contained in the draft contract before providing a bid. If a bidder submits a bid and then negotiations on the contract become protracted, the city has the right and authority to suspend negotiations, enter into negotiation with the next lowest and best bidder and execute upon the bid bond.

BONDS AND INSURANCE REQUIREMENTS

As required by law, the bidder must furnish and execute in triplicate the required bonds in favor of the City of Midwest City. The bonds must be submitted on the standard bond forms provided in the bidding documents. The required bonds are:

a. Performance Bond

The performance bond guarantees the contractor's full and faithful execution of the work and performance of the contract and for the protection of the city and all property owners against any damage by reason of acts or omissions of the contractor or the improper execution of the work or the use of inferior materials.

b. Statutory Bond

The statutory bond guarantees that the contractor will make payment for all labor, materials and equipment used in the project.

c. Maintenance Bond

The maintenance bond guarantees the maintenance in good condition of the workmanship and materials for a specified period after completion and acceptance of the project by the city. The maintenance period is specified in the contract documents. The bond for the maintenance period is in an amount equal to one hundred percent (100%) of the contract amount.

The typical maintenance periods for the city projects are as follows:

1 Year All water, sanitary sewer, and drainage improvements installed separate from any road or bridge work.

2 Years All buildings and park projects, all drainage improvement projects, except those portions of drainage improvement that are placed under streets which shall be bonded for five (5) years.

5 Years All street and bridge projects including water, sanitary sewer, and drainage improvements installed directly in conjunction with those projects.

SECTION A
SPECIAL PROVISIONS

1. GENERAL DESCRIPTION OF WORK

The work to be performed under the provisions of these contract documents consists of the following: furnishing all materials, equipment, tools and plant; the performance of all necessary labor; and the complete construction of facilities, including all work appurtenant thereto.

2. GENERAL CONDITIONS

The General Conditions are general in scope and may refer to conditions not encountered on the work covered by this contract. Any provision of the General Conditions which pertains to a nonexistent condition and is not applicable to the work to be performed hereunder, or which conflicts with any provision of the Special Conditions, shall have no meaning in the contract and shall be disregarded.

3. SPECIFICATIONS

The specifications that govern the materials and equipment to be furnished and the work to be performed under this contract are listed in the following paragraphs. No attempt has been made in the specifications to segregate work that is to be performed by any trade or subcontract. Any segregation between trades or crafts will be solely a matter for agreement between the Contractor and his employees and his subcontractors.

All work performed under this contract shall be in full accordance with the laws and ordinances pertinent to such work. In case of any conflict wherein the methods or standards of installation or materials specified do not equal or exceed the requirements of the laws or ordinances, the laws or ordinances shall govern. All items required by the laws or ordinances but not specified or shown on the drawings shall be furnished without extra charge as shown or specified.

These Special Provisions are supplemental to the City of Midwest City requirements, current edition which govern all areas/types of construction and shall be considered as a part of these specifications and contract. Where the stipulations of the Special Provisions, and Midwest City, specifications or plans are in conflict, the interpretation of the plans and specifications shall be made by the City.

The words "laws and ordinances" as used herein shall mean all local, state, or national codes, laws, ordinances, standards, rules, or regulations of any nature which are in any way pertinent to, or regulatory over, the work covered by this contract.

4. PERMITS AND FEES

The Contractor shall secure all necessary permits or licenses to carry out this work and he shall pay all lawful fees, taxes, etc., in connection with the work.

5. EQUIVALENT MATERIALS AND EQUIPMENT

Whenever a material or article is specified or described by using the name of a proprietary product or the name of a particular manufacturer or vendor, the specific item mentioned

shall be understood as establishing the type, function and quality desired, unless specifically stated otherwise. Other manufacturers' products will be accepted provided sufficient information is submitted to allow the Engineer for the City of Midwest City (hereinafter "Engineer") to determine that the proposed products are equivalent to those named. Such items shall be submitted for approval by the procedure set forth in the SECTION B, General Conditions, 5. Shop Drawings. The words "or approved equal," although possibly not indicated after each proprietary specification, are implied as a result of the preceding statements in this paragraph.

6. WATER

The City will furnish all water that is required in connection with the work to be done under this contract in the vicinity of the site without charge, provided:

- a. The Contractor shall procure such water in the location and in the manner designated by the Engineer.
- b. The Contractor, at his own expense, shall make authorized connections and provide means for delivering the water to the work site.
- c. The Contractor shall provide adequately against waste and needless use of such water.
- d. The City shall provide a backflow preventer valve for the Contractor's use. The backflow preventer must be used at all times.

10. FIELD CHECK OF EXISTING STRUCTURES

It shall be the responsibility of the Contractor to check and verify all dimensions and elevations of existing structures, pipelines, equipment, or other existing items affected by or affecting the work under this contract. This shall be done prior to the start of construction or ordering of materials and equipment affected thereby.

The Contractor's attention is directed to the Advertisement for Bids which requires that each bidder visit the site of the work to familiarize himself with the arrangement and condition of existing construction. The drawings (in general) show only the details of existing construction that are to be connected to or that are to remain in place. The Contractor shall repair, to the Owner's satisfaction, any existing infrastructure, including private materials located in the City right of way, at no expense to the City and shall not constitute a claim by the Contractor for extra work, additional payment, or damages.

The Contractor shall be solely responsible for determining the extent and cost of all removal and salvage operations. Any delay or extra expense to the Contractor due to encountering construction, piping, or equipment not shown or in locations different from those indicated on the plans shall not constitute a claim by the Contractor for extra work, additional payment, or damages.

11. DAMAGE TO EXISTING PROPERTY

The Contractor will be held responsible for any damage to existing structures, work, materials, or equipment because of his operations; and shall repair or replace any damaged structures, work, materials, or equipment to the satisfaction of and at no additional cost to the City. The Contractor shall protect all existing structures and property (such as irrigation, landscaping, etc.) from such damage and shall provide bracing, shoring, or other work necessary for such protection.

12. SCHEDULE OF CONSTRUCTION OPERATIONS

The Contractor shall submit to the Engineer for approval, before starting work, a schedule of his proposed construction operations. He will be required to consult with the Engineer and a schedule shall be established whereby the proposed construction operations may be executed with a minimum of interruption to the normal water service. The City will fully cooperate with the Contractor in arrangements for continuity of service and operation of valves and other control facilities. The schedule of operations shall indicate the sequence of the work, the time of starting and completion of each part, and the time for making connections to existing pipes, structures, or any other facilities.

If conditions beyond the control of the Contractor justify, and the City approves an extension of contract time, the Contractor shall revise the construction schedule in accordance with the approved extension. If operations fall behind the approved schedule to an extent that the completion of the work within the specified time appears doubtful, the City may require the Contractor to add to his plant, equipment, or construction forces, and/or increase the working hours.

Approval of the proposed construction schedule by the Engineer is necessary before the actual performance of the work, but it shall not relieve the Contractor of his obligations to cooperate with the City to the fullest extent.

13. RIGHTS-OF-WAY

The Contractor shall be solely responsible for obtaining (and shall pay all costs in connection with) any additional work area, storage sites, access to the site, or temporary right-of-way which may be required for proper completion of the work.

It shall be clearly understood that the responsibility for the protection and safekeeping of equipment and materials on or near the site will be entirely that of the Contractor and that no claim shall be made against the City by reason of any act of any employee or trespasser. It shall be further understood that, should any occasion arise necessitating access to the sites occupied by these stored materials or equipment, the Contractor owning or responsible for the stored materials or equipment shall immediately move same. No materials or equipment may be placed upon the property of the City until the City has approved the location contemplated by the Contractor to be used for storage.

14. PROTECTION AND MAINTENANCE OF PUBLIC AND PRIVATE PROPERTY

The Contractor shall protect, shore, brace, support, and maintain all underground pipes, conduits, drains and other underground construction uncovered or otherwise affected by the construction work performed by him. All pavement, surfacing, driveway, curbs, walks, buildings, utility poles, guy wires, fences, and other surface structures affected by construction operations, together with all shrubs in yards and parking, shall be restored to their original condition as determined and approved by the Engineer, within or outside the City's right-of-way. All replacements shall be made with new materials.

15. SAFETY REQUIREMENTS

The Contractor shall familiarize himself and his employees with the requirements of the U.S. Labor Department's Occupational Safety and Health Administration Standards. He shall work in accordance with these OSHA Standards and Regulations.

16. ESTIMATED QUANTITIES

All estimated quantities stipulated in the bid or other contract documents are approximate and are to be used only (a) as a basis for estimating the probable cost of the work and (b) for the purpose of comparing the bids submitted for the work. The actual amounts of work done and materials furnished under unit price items may differ from the estimated quantities. The basis of payment for work and materials will be the actual amount of work done and materials furnished, unless a pay item is identified to be paid per plan quantities. The Contractor agrees that he will make no claim for damages, anticipated profits, or other factors, which are due to any difference between the amounts of work actually performed and materials actually furnished and the estimated amounts thereof.

17. SPECIAL NOTICE

The specifications are complete as written. No oral representations made by any agent or employee of the City or its affiliate agencies shall be of any force or effect unless reduced to writing and submitted to all prospective bidders at least 24 hours in advance of the Bid Opening.

Any protest of the award of this proposed contract to the lowest and best bidder by any bidder on the contract shall be in writing, shall specify the grounds for the protest in specific terms and shall be received by the City within three (3) business days after the award of the contract by the governing body. The governing body reserves the right to review all bids and make the award to the lowest and best bidder. All other provisions of these specifications shall also apply.

18. APPLICABLE LAWS

Contractor and its subcontractors shall at all times comply with all applicable laws (including, but not limited to, the Occupational Safety and Health Act of 1970), ordinances, rules, regulations, codes and orders of the United States, any state, county or any executive or administrative agency thereof and any other governmental body having any jurisdiction over the work and with the safety rules and regulations of the City in force at the facility, and all materials, equipment, and work shall comply therewith. All required personal safety items, including gloves, protective headgear, steel-toed footwear, and safety glasses shall be provided by the Contractor at no expense to the City.

19. CONTRACT TIME AND CITY OF MIDWEST CITY HOURS OF OPERATION

The contract time allowed for completion of the project, as specified in the bid, expressed in consecutive calendar days, is that time estimated for completion and related testing of all items of work based on a five (5) day work week, eight (8) hours worked per day Monday-Thursday. Four (4) work day Friday. Normal inclement weather days have been included in the contract time estimate.

The City of Midwest City engineering division observes working hours of 7:30 a.m. to 5:30 p.m., Monday through Thursday, 7:30 a.m. to 11:30 a.m. Friday, excluding designated holidays. Work requiring inspection by the City must be performed during these observed times and days of operation. Inspection services can be provided outside the observed times and days of operation at the Contractor's request and with approval of the City. Requests must be submitted in writing to the City at least twenty-four (24) hours prior to the time requested, excluding weekends and holidays. The request must state day(s), time(s), and reason(s) in order for the City to evaluate the request and to schedule staff accordingly.

Requests received less than 24 hours prior to the day(s) and time(s) of the requested inspections will not be honored.

20. BASIS OF PAYMENT

The prices bid shall be full compensation for all labor, materials, tools, equipment, and incidentals necessary to complete the work in accordance with the plans, these specifications, and the referenced City of Midwest City and Oklahoma Department of Transportation specifications.

SECTION B
GENERAL CONDITIONS

1 DEFINITIONS

Wherever used in the CONTRACT DOCUMENTS, the following terms shall have the meanings indicated which shall be applicable to both the singular and plural thereof:

- a. ADDENDA - Written or graphic instruments issued prior to the execution of the Contract which modify or interpret the CONTRACT DOCUMENTS, DRAWINGS and SPECIFICATIONS by additions, deletions, clarifications or corrections.
- b. BID - The offer or proposal of the SERVICE PROVIDER submitted on the prescribed form setting forth the prices for the WORK to be performed.
- c. BONDS - Bid, Performance, Statutory and Maintenance Bonds and other instruments of security furnished by the CONTRACTOR and his surety in accordance with the CONTRACT DOCUMENTS.
- d. CHANGE ORDER - A written order to the CONTRACTOR authorizing an addition, deletion or revision in the WORK within the general scope of the CONTRACT DOCUMENTS, or authorizing an adjustment in the CONTRACT PRICE or CONTRACT TIME.
- e. CONTRACT DOCUMENTS - The CONTRACT, BONDS, NOTICE OF AWARD, NOTICE TO PROCEED, CHANGE ORDER, DRAWINGS, SPECIFICATIONS and ADDENDA.
- f. CONTRACT PRICE - The total monies payable to the CONTRACTOR under the terms and conditions of the CONTRACT DOCUMENTS.
- g. CONTRACT TIME - The number of calendar days stated in the CONTRACT DOCUMENTS for the completion of the WORK.
- h. CONTRACTOR - The person, firm or corporation with whom the OWNER has executed the contract.
- i. DRAWINGS - The part of the CONTRACT DOCUMENTS which show the characteristics and scope of the WORK to be performed and which have been prepared or approved by the ENGINEER.
- j. ENGINEER - The City Engineer for the City of Midwest City.
- k. FIELD ORDER - A written order effecting a change in the WORK, not involving an adjustment in the CONTRACT PRICE or an extension of the CONTRACT TIME, issued by the ENGINEER to the CONTRACTOR during construction.
- l. NOTICE OF AWARD - The written notice of the acceptance of the BID from the OWNER to the successful SERVICE PROVIDER .
- m. NOTICE TO PROCEED - Written communication issued by the OWNER to the CONTRACTOR authorizing him to proceed with the WORK and establishing the date of commencement of the WORK.
- n. OWNER - City of Midwest City, a municipal corporation for whom the WORK is to be performed.
- o. PROJECT - The undertaking to be performed as provided in the CONTRACT DOCUMENTS.

- p. RESIDENT PROJECT REPRESENTATIVE - The authorized representative of the OWNER who is assigned to the PROJECT site or any part thereof.
- q. SERVICE PROVIDER or BIDDER - Any person, firm or corporation submitting a BID for the work.
- r. SHOP DRAWINGS - All drawings, diagrams, illustrations, brochures, schedules and other data which are prepared by the CONTRACTOR, a SUBCONTRACTOR, manufacturer, supplier or distributor, which illustrate how specific portions of the WORK shall be fabricated or installed.
- s. SPECIFICATIONS - A part of the CONTRACT DOCUMENTS consisting of written descriptions of a technical nature of materials, equipment construction systems, standards and workmanship.
- t. SUBCONTRACTOR - An individual, firm or corporation having a direct contract with the CONTRACTOR or with any other SUBCONTRACTOR for the performance of a part of the WORK at the site.
- u. SUBSTANTIAL COMPLETION - That date as certified by the ENGINEER when the construction of the PROJECT or a specified part thereof is sufficiently completed, in accordance with the CONTRACT DOCUMENTS, so that the PROJECT or specified part can be utilized for the purposes for which it was intended.
- v. SUPPLEMENTAL GENERAL CONDITIONS - Modifications to General Conditions required by a federal agency for participation in the PROJECT and approved by the agency in writing prior to inclusion in the CONTRACT DOCUMENTS.
- w. WORK - All labor necessary to produce the construction required by the CONTRACT DOCUMENTS, and all materials and equipment incorporated or to be incorporated in the PROJECT.
- x. WRITTEN NOTICE - Any notice to any party of the contract relative to any part of the contract in writing and considered delivered and the service thereof completed when posted by certified or registered mail to the party at his last given address or delivered in person to said party or his authorized representative on the PROJECT.

2 ADDITIONAL INSTRUCTIONS AND DETAIL DRAWINGS

- a. The CONTRACTOR may be furnished additional instructions and detail drawings, by the ENGINEER, as necessary to carry out the WORK required by the CONTRACT DOCUMENTS.
- b. The additional drawings and instructions thus supplied will become a part of the CONTRACT DOCUMENTS. The CONTRACTOR shall carry out the WORK in accordance with the additional detail drawings and instructions.

3 SCHEDULES, REPORTS AND RECORDS

- a. The CONTRACTOR shall submit to the OWNER such schedule of quantities and costs, progress schedules, payrolls, reports, estimates, records and other data as the OWNER may request concerning WORK performed or to be performed.
- b. Prior to the first partial payment estimate the CONTRACTOR shall submit schedules showing the order in which he proposes to carry on the WORK, including dates at which he will start the various parts of the WORK, estimated date of completion of each part and, as applicable:
 - (1) The dates at which special detail drawings will be required; and

- (2) Respective dates for submission of SHOP DRAWINGS, the beginning of manufacture, the testing and the installation of materials, supplies and equipment.
- c. The CONTRACTOR shall also submit a schedule of payments that he anticipates he will earn during the course of the WORK.

4 DRAWINGS AND SPECIFICATIONS

- a. The intent of the DRAWINGS and SPECIFICATIONS is that the CONTRACTOR shall furnish all labor, materials, tools, equipment and transportation necessary for the proper execution of the WORK in accordance with the CONTRACT DOCUMENTS and all incidental work necessary to complete the PROJECT in an acceptable manner, ready for use, occupancy or operation by the OWNER.
- b. In case of conflict between the DRAWINGS and SPECIFICATIONS, the SPECIFICATIONS shall govern. Figure dimensions on DRAWINGS shall govern over scale dimensions and detailed DRAWINGS shall govern over general DRAWINGS.
- c. Any discrepancies found between the DRAWINGS and SPECIFICATIONS and site conditions or any inconsistencies or ambiguities in the DRAWINGS or SPECIFICATIONS shall be immediately reported to the ENGINEER, in writing, who shall promptly correct such inconsistencies or ambiguities in writing. WORK done by the CONTRACTOR after his discovery of such discrepancies, inconsistencies or ambiguities shall be done at the CONTRACTOR's risk.

5 SHOP DRAWINGS

- a. The CONTRACTOR shall provide SHOP DRAWINGS, in triplicate, as may be necessary for the prosecution of the WORK as required by the CONTRACT DOCUMENTS. The ENGINEER shall promptly review all SHOP DRAWINGS. The ENGINEER's approval of any SHOP DRAWING shall not release the CONTRACTOR from responsibility for deviations from the CONTRACT DOCUMENTS. The approval of any SHOP DRAWING which substantially deviates from the requirement of the CONTRACT DOCUMENTS shall be evidenced by a CHANGE ORDER.
- b. When submitted for the ENGINEER's review, SHOP DRAWINGS shall bear the CONTRACTOR's certification that he has reviewed, checked and approved the SHOP DRAWINGS and that they are in conformance with the requirements of the CONTRACT DOCUMENTS.
- c. Portions of the WORK requiring a SHOP DRAWING or sample submission shall not begin until the SHOP DRAWING, or submission, has been approved by the ENGINEER. A copy of each approved SHOP DRAWING and each approved sample shall be kept in good order by the CONTRACTOR at the site and shall be available to the ENGINEER.

6 MATERIALS, SERVICES AND FACILITIES

- a. It is understood that, except as otherwise specifically stated in the CONTRACT DOCUMENTS, the CONTRACTOR shall provide any pay for all materials, labor, tools, equipment, water, light, power, transportation, supervision, temporary construction of any nature and all other services and facilities of any nature whatsoever necessary to execute, complete and deliver the WORK within the specified time.

- b. Materials and equipment shall be so stored as to insure the preservation of their quality and fitness for the WORK. Stored materials and equipment to be incorporated in the WORK shall be located as to facilitate prompt inspection.
- c. Manufactured articles, materials and equipment shall be applied, installed, connected, erected, used, cleaned and conditioned as directed by the manufacturer.
- d. Materials, supplies and equipment shall be in accordance with samples submitted by the CONTRACTOR and approved by the ENGINEER.
- e. Materials, supplies or equipment to be incorporated into the WORK shall not be purchased by the CONTRACTOR or the SUBCONTRACTOR subject to a chattel mortgage or under a conditional sale contract or other agreement by which an interest is retained by the seller.

7 INSPECTION AND TESTING

- a. All materials and equipment used in the construction of the PROJECT shall be subject to adequate inspection and testing in accordance with generally accepted standards.
- b. The CONTRACTOR shall provide at his expense the necessary testing and inspection services required by the CONTRACT DOCUMENTS, unless otherwise provided.
- c. The OWNER shall provide all other inspection and testing services not required by the CONTRACT DOCUMENTS.
- d. If the CONTRACT DOCUMENTS, laws, ordinances, rules, regulations or orders of any public authority having jurisdiction require any WORK to specifically be inspected, tested or approved by someone other than the CONTRACTOR, the CONTRACTOR will give the ENGINEER timely notice of readiness. The CONTRACTOR will then furnish the ENGINEER the required certificates of inspection, testing or approval.
- e. Neither observations by the ENGINEER nor inspections, tests or approvals by persons other than the CONTRACTOR shall relieve the CONTRACTOR from his obligations to perform the WORK in accordance with the requirements of the CONTRACT DOCUMENTS.
- f. The ENGINEER and his representatives will at all times have access to the WORK. In addition, authorized representatives and agents of any participating federal or state agency shall be permitted to inspect all work, materials, payrolls, records of personnel, invoices of materials and other relevant data and records. The CONTRACTOR will provide proper facilities for such access and observation of the WORK and also for any inspection or testing thereof.
- g. If any WORK is covered contrary to the written request of the ENGINEER, it must, if requested by the ENGINEER, be uncovered for his observation and replaced at the CONTRACTOR's expense.
- h. If any WORK has been covered that the ENGINEER has not specifically requested to observe prior to its being covered, or if the ENGINEER considers it necessary or advisable that covered WORK be inspected or tested by others, the CONTRACTOR at the ENGINEER's request will uncover, expose or otherwise make available for observation, inspection or testing, as the ENGINEER may require, that portion of the WORK in question, furnishing all necessary labor, materials, tools and equipment. If it is found that such WORK is defective, the CONTRACTOR will bear all the expense of such uncovering, exposure, observation, inspection and testing and of satisfactory reconstruction. If, however, such WORK is not found to be defective, the CONTRACTOR will be allowed an increase in the CONTRACT PRICE or an extension of the CONTRACT TIME, or both, directly attributable to such uncovering, exposure, observation,

inspection, testing and reconstruction, and an appropriate CHANGE ORDER shall be issued as the term CHANGE ORDER is defined in Section B, General Conditions, (1)(e).

8 SUBSTITUTIONS

- a. When a material, article or piece of equipment is identified on the DRAWINGS or SPECIFICATIONS by reference to brand name or catalogue number, it shall be understood that this is referenced for the purpose of defining the performance or other salient requirements and that other products of equal capacities, quality and function shall be considered. The CONTRACTOR may recommend the substitution of a material, article or piece of equipment of equal substance and function for those referred to in the CONTRACT DOCUMENTS by reference to brand name or catalogue number and if, in the opinion of the ENGINEER, such material, article or piece of equipment is of equal substance and function to that specified, the ENGINEER may approve its substitution and use by the CONTRACTOR. Any cost differential shall be deductible from the CONTRACT PRICE and the CONTRACT DOCUMENTS shall be appropriately modified by CHANGE ORDER. The CONTRACTOR warrants that, if substitutes are approved, no major changes in the function or general design of the PROJECT will result. Incidental changes or extra component parts required to accommodate the substitute will be made by the CONTRACTOR without a change in the CONTRACT PRICE or CONTRACT TIME.

9 PATENTS

- a. The CONTRACTOR shall pay all applicable royalties and license fees. He shall defend all suits or claims for infringement of any patent rights and save the OWNER harmless from loss on account thereof, except that the OWNER shall be responsible for any such loss when a particular process, design or the product of a particular manufacturer or manufacturers is specified but, if the CONTRACTOR has reason to believe that the design, process or product specified is an infringement of a patent, he shall be responsible for such loss unless he promptly gives such information to the ENGINEER.

10 SURVEYS, PERMITS, REGULATIONS

- a. The OWNER shall furnish and establish all base lines for locating the principal component parts of the WORK together with a suitable number of bench marks adjacent to the WORK as shown in the CONTRACT DOCUMENTS. From the information provided by the OWNER, unless otherwise specified in the CONTRACT DOCUMENTS, the CONTRACTOR shall develop and make all detail surveys needed for construction such as cut stakes, offset stakes and other working points, lines, elevations and cut sheets.
- b. The CONTRACTOR shall carefully preserve bench marks, reference points and stakes and, in case of willful or careless destruction, he shall be charged with the resulting expense and shall be responsible for any mistakes that may be caused by their unnecessary loss or disturbance.
- c. Permits and licenses of a temporary nature necessary for the prosecution of the WORK shall be secured and paid for by the CONTRACTOR. Permits, licenses, and easements for permanent structures or permanent changes in existing facilities shall be secured and paid for by the OWNER unless otherwise specified. The CONTRACTOR shall give all notices and comply with all laws, ordinances, rules and regulations bearing on the conduct of the WORK as drawn and specified. If the CONTRACTOR observes that the CONTRACT DOCUMENTS are at variance therewith, he shall promptly notify the ENGINEER in writing and any necessary changes shall be adjusted as provided in Section 12, CHANGES IN THE WORK.

11 PROTECTION OF WORK, PROPERTY AND PERSONS

- a. The CONTRACTOR will supervise and direct the WORK. He will be solely responsible for the means, methods, techniques, sequences and procedures of construction. The CONTRACTOR will employ and maintain on the WORK a qualified supervisor or superintendent who shall have been designated in writing by the CONTRACTOR as the CONTRACTOR's representative at the site. The supervisor shall have full authority to act on behalf of the CONTRACTOR and all communications given to the supervisor shall be as binding as if given to the CONTRACTOR. The supervisor shall be present on the site at all time as required to perform adequate supervision and coordination of the WORK.
- b. The CONTRACTOR will comply with all applicable laws, ordinances, rules, regulations and orders of any public body having jurisdiction. He will erect and maintain, as required by the conditions and progress of the WORK, all necessary safeguards for safety and protection. He will notify owners of adjacent utilities when prosecution of the WORK may affect them. The CONTRACTOR will remedy all damage, injury or loss to any property caused, directly or indirectly, declared or not, in whole or in part, by the CONTRACTOR, any SUBCONTRACTOR or anyone directly or indirectly employed by any of them, or anyone for whose acts any of them be liable, except damages or loss attributable to the fault of the CONTRACT DOCUMENTS or to the acts or omissions of the OWNER or the ENGINEER or anyone employed by either of them or anyone for whose acts either of them may be liable, and not attributable, directly or indirectly, in whole or in part, to the fault or negligence of the CONTRACTOR.
- c. In emergencies affecting the safety of persons or the WORK or property at the site or adjacent thereto, the CONTRACTOR, without special instruction or authorization from the ENGINEER or the OWNER, shall act to prevent threatened damage, injury or loss. He will give the ENGINEER prompt WRITTEN NOTICE of any significant changes in the WORK or deviations from the CONTRACT DOCUMENTS caused thereby, and a CHANGE ORDER shall thereupon be issued covering the changes and deviations involved.

12 CHANGES IN THE WORK

- a. The OWNER may at any time, as the need arises, order change within the scope of the WORK without invalidating the contract. If such changes increase or decrease the amount due under the CONTRACT DOCUMENTS, or in the time required for performance of the WORK, an equitable adjustment shall be authorized by CHANGE ORDER.
- b. The ENGINEER also may at any time, by issuing a FIELD ORDER, make changes in the details of the WORK. The CONTRACTOR shall proceed with the performance of any changes in the WORK so ordered by the ENGINEER unless the CONTRACTOR believes that such FIELD ORDER entitles him to a change in CONTRACT PRICE or TIME, or both, in which event he shall give the ENGINEER WRITTEN NOTICE thereof within fifteen (15) days after the receipt of the ordered change and the CONTRACTOR shall not execute such changes pending the receipt of an executed CHANGE ORDER or further instruction from the OWNER.

13 CHANGES IN CONTRACT PRICE

- a. The CONTRACT PRICE may be changed only by a CHANGE ORDER. The value of any WORK covered by a CHANGE ORDER or of any claim for increase or decrease in the CONTRACT PRICE shall be determined by one or more of the following methods in the order of precedence listed below:

- (1) Unit prices previously approved.
- (2) An agreed lump sum.
- (3) The actual cost for labor, direct overhead, materials, supplies, equipment, and other services necessary to complete the WORK. In addition there shall be added an amount to be agreed upon but not to exceed fifteen percent (15%) of the actual cost of the WORK to cover the cost of general overhead and profit.

14 TIME FOR COMPLETION

- a. The date of beginning and the time for completion of the WORK are essential conditions of the CONTRACT DOCUMENTS and the WORK embraced shall be commenced on a date specified in the NOTICE TO PROCEED.
- b. All CONTRACTS are calendar day length contracts. There are no provisions for weather days. Weather days have been factored into the total days provided in the CONTRACT.
- c. Arbitration for the extension of TIME FOR COMPLETION is prohibited.
- d. The CONTRACTOR will proceed with the WORK at such rate of progress to insure full completion within the CONTRACT TIME. It is expressly understood and agreed, by and between the CONTRACTOR and the OWNER, that the CONTRACT TIME for the completion of the WORK described herein is a reasonable time, taking into consideration the average climatic and economic conditions and other factors prevailing in the locality of the WORK.
- e. If the CONTRACTOR shall fail to complete the WORK within the CONTRACT TIME, or extension of time granted by the OWNER, then the CONTRACTOR will pay to the OWNER the amount for liquidated damages as specified in the BID for each calendar day that the CONTRACTOR shall be in default after the time stipulated in the CONTRACT DOCUMENTS.
- f. The CONTRACTOR shall not be charged with liquidated damages or any excess cost when the delay in completion of the WORK is due to the following and the CONTRACTOR has promptly given WRITTEN NOTICE of such delay to the OWNER or ENGINEER:
 - (1) To any preference, priority or allocation order duly issued by the OWNER.
 - (2) To unforeseeable causes beyond the control and without the fault or negligence of the CONTRACTOR including, but not restricted to, acts of God or of the public enemy, acts of the OWNER, acts of another contractor in the performance of a contract with the OWNER, fires, floods, epidemics, quarantine restrictions, strikes; and
 - (3) To any delays of SUBCONTRACTORS occasioned by any of the causes specified in paragraphs 14.f.(1) and 14.f.(2) of this article.

15 CORRECTION OF WORK

- a. The CONTRACTOR shall promptly remove from the premises all WORK rejected by the ENGINEER for failure to comply with the CONTRACT DOCUMENTS, whether incorporated in the construction or not, and the CONTRACTOR shall promptly replace and re-execute the WORK in accordance with the CONTRACT DOCUMENTS and without expense to the OWNER and shall bear the expense of making good all WORK of other contractors destroyed or damaged by such removal or replacement.
- b. All removal and replacement WORK shall be done at the CONTRACTOR's expense. If the CONTRACTOR does not take action to remove such rejected WORK within ten (10) days after receipt of WRITTEN NOTICE, the OWNER may remove such WORK and store the materials at the expense of the CONTRACTOR.

16 SUBSURFACE CONDITIONS

- a. The CONTRACTOR shall promptly, and before such conditions are disturbed, except in the event of an emergency, notify the OWNER by WRITTEN NOTICE of:
 - (1) Subsurface or latent physical conditions at the site differing materially from those indicated in the CONTRACT DOCUMENTS; or
 - (2) Unknown physical conditions at the site, of an unusual nature, differing materially from those ordinarily encountered and generally recognized as inhering in WORK of the character provided for in the CONTRACT DOCUMENTS.
- b. The OWNER shall promptly investigate the conditions and, if it finds that such conditions do so materially differ and cause an increase or decrease in the cost of, or in the time required for, performance of the WORK, an equitable adjustment shall be made and the CONTRACT DOCUMENTS shall be modified by a CHANGE ORDER. Any claim of the CONTRACTOR for adjustment hereunder shall not be allowed unless he has given the required WRITTEN NOTICE; provided that the OWNER may, if it determines the facts so justify, consider and adjust any such claims asserted before the date of final payment.

17 SUSPENSION OF WORK, TERMINATION AND DELAY

- a. The OWNER may, at any time and without cause, suspend the WORK or any portion thereof for a period of not more than ninety days, or such further time as agreed upon by the CONTRACTOR, by WRITTEN NOTICE to the CONTRACTOR and the ENGINEER which notice shall fix the date on which WORK shall be resumed. The CONTRACTOR will resume the WORK on the date so fixed. The CONTRACTOR will be allowed an increase in the CONTRACT PRICE or an extension of the CONTRACT TIME, or both, directly attributable to any suspension.
- b. If the CONTRACTOR is adjudged bankrupt or insolvent, or if he makes a general assignment for the benefit of his creditors, or if a trustee or receiver is appointed for the CONTRACTOR or for any of his property, or if he files a petition to take advantage of any debtor's act, or to reorganize under the bankruptcy or applicable laws, or if he repeatedly fails to supply sufficient skilled workmen or suitable materials or equipment, or if he repeatedly fails to make prompt payments to SUBCONTRACTORS or for labor, materials or equipment or if he disregards laws, ordinances, rules, regulations or orders of any public body having jurisdiction of the WORK or if he disregards the authority of the ENGINEER, or if he otherwise violates any provision of the CONTRACT DOCUMENTS, then the OWNER may, without prejudice to any other right or remedy and after giving the CONTRACTOR and his surety a minimum of ten (10) days WRITTEN NOTICE, terminate the services of the CONTRACTOR and take possession of the PROJECT and of all materials, equipment, tools, construction equipment and machinery thereon owned by the CONTRACTOR, and finish the WORK by whatever method it may deem expedient. In such case, the CONTRACTOR shall not be entitled to receive any further payment until the WORK is finished. If the unpaid balance of the CONTRACT PRICE exceeds the direct and indirect costs of completing the PROJECT, including compensation for additional professional services, such excess shall be paid to the CONTRACTOR. If such costs exceed such unpaid balance, the CONTRACTOR will pay the difference to the OWNER. Such costs incurred by the OWNER will be determined by the ENGINEER and incorporated in a CHANGE ORDER.
- c. Where the CONTRACTOR's services have been so terminated by the OWNER, said termination shall not affect any right of the OWNER against the CONTRACTOR then existing or which may thereafter accrue. Any retention or payment of monies by the OWNER due the

CONTRACTOR will not release the CONTRACTOR from compliance with the CONTRACT DOCUMENTS.

- d. After ten (10) days from delivery of a WRITTEN NOTICE to the CONTRACTOR and the ENGINEER, the OWNER may, without cause and without prejudice to any other right or remedy, elect to abandon the PROJECT and terminate the contract. In such case, the CONTRACTOR shall be paid for all WORK executed and any expense plus reasonable profit.
- e. If, through no act or fault of the CONTRACTOR, the WORK is suspended for a period of more than ninety (90) days by the OWNER or under an order of court or other public authority, or the ENGINEER fails to act on any request for payment within thirty (30) days after it is submitted, or the OWNER fails to pay the CONTRACTOR substantially the sum approved by the ENGINEER or awarded by court order or legal proceeding within thirty (30) days of its approval and presentation, then the CONTRACTOR may, after ten (10) days from delivery of a WRITTEN NOTICE to the OWNER and the ENGINEER, terminate the CONTRACT and recover from the OWNER payment for all WORK executed and all expenses sustained. In addition and in lieu of terminating the CONTRACT, if the ENGINEER has failed to act on a request for payment or if the OWNER has failed to make any payment as aforesaid, the CONTRACTOR may upon ten (10) days' notice to the OWNER and the ENGINEER stop the WORK until he has been paid all amounts then due, in which event and upon resumption of the WORK, CHANGE ORDERS shall be issued for adjusting the CONTRACT PRICE or extending the CONTRACT TIME, or both, to compensate for the costs and delays attributable to the stoppage of the WORK.
- f. If the performance of all or any portion of the WORK is suspended, delayed or interrupted as a result of a failure of the OWNER or ENGINEER to act within the time specified in the CONTRACT DOCUMENTS or, if no time is specified, within a reasonable time, adjustment in the CONTRACT PRICE or an extension of the CONTRACT TIME, or both, shall be made by CHANGE ORDER to compensate the CONTRACTOR for the costs and delays necessarily caused by the failure of the OWNER or ENGINEER.

18 PAYMENTS TO CONTRACTOR

- a. At least ten (10) days before each progress payment falls due (but not more often than once a month), the CONTRACTOR will submit to the ENGINEER a partial payment estimate filled out and signed by the CONTRACTOR covering the WORK performed during the period covered by the partial payment estimate and supported by such data as the ENGINEER may reasonably require. If payment is requested on the basis of materials and equipment not incorporated in the WORK but delivered and suitably stored at or near the site, the partial payment estimate shall also be accompanied by such supporting data, satisfactory to the OWNER, as will establish the OWNER's title to the material and equipment and protect its interest therein, including applicable insurance. The ENGINEER will, within ten days after receipt of each partial payment estimate, either indicate in writing his approval of payment and present the partial payment estimate to the OWNER, or return the partial payment estimate to the CONTRACTOR indicating in writing his reasons for refusing to approve payment. In the latter case, the CONTRACTOR may make the necessary corrections and resubmit the partial payment estimate. The OWNER will, within ten (10) days of presentation to him of an approved partial payment estimate, pay the CONTRACTOR a progress payment on the basis of the approved partial payment estimate. The OWNER shall retain five percent (5%) of the amount of each payment until fifty percent (50%) project completion and retain two and a half (2.5%) after to final completion and acceptance of all WORK covered by the CONTRACT DOCUMENTS. On completion and acceptance of a part of the WORK on which the price is

stated separately in the CONTRACT DOCUMENTS, payment may be made in full, including retained percentages, less authorized deductions.

- b. The request for payment may also include an allowance for the cost of such major materials and equipment which are suitably stored either at or near the site.
- c. All WORK covered by partial payment made shall thereupon become the sole property of the OWNER, but this provision shall not be construed as relieving the CONTRACTOR of the sole responsibility for the care and protection of the WORK upon which payments have been made or the restoration of any damaged WORK, or as a waiver of the right of the OWNER to require the fulfillment of all terms of the CONTRACT DOCUMENTS.
- d. Upon completion and acceptance of the WORK, the ENGINEER shall issue a certificate attached to the final payment request that the WORK has been accepted by him under the conditions of the CONTRACT DOCUMENTS. The entire balance found to be due the CONTRACTOR, including the retained percentages, but except such sums as may be lawfully retained by the OWNER shall be paid to the CONTRACTOR within thirty (30) days of completion and acceptance by the OWNER of the WORK.
- e. The CONTRACTOR will indemnify and save the OWNER and the OWNER's agents harmless from all claims growing out of the lawful demands of SUBCONTRACTORS, laborers, workmen, mechanics, materialmen and furnishers of machinery and parts thereof, equipment, tools and all supplies incurred in the furtherance of the performance of the WORK. The CONTRACTOR shall, at the OWNER's request, furnish satisfactory evidence that all obligations of the nature designated above have been paid, discharged or waived. If the CONTRACTOR fails to do so the OWNER may, after having notified the CONTRACTOR, either pay unpaid bills or withhold from the CONTRACTOR's unpaid compensation a sum of money deemed reasonably sufficient to pay any and all such lawful claims until satisfactory evidence is furnished that all liabilities have been fully discharged whereupon payment to the CONTRACTOR shall be resumed, in accordance with the terms of the CONTRACT DOCUMENTS, but in no event shall the provisions of this sentence be construed to impose any obligations upon the OWNER. Such payment(s) shall be considered as a payment made under the CONTRACT DOCUMENTS by the OWNER to the CONTRACTOR and the OWNER shall not be liable to the CONTRACTOR for any such payments made in good faith.
- f. If the OWNER fails to make payment thirty (30) days after approval by the ENGINEER, in addition to other remedies available to the CONTRACTOR, there shall be added to each such payment interest at the maximum legal rate commencing on the first day after said payment is due and continuing until the payment is received by the CONTRACTOR.

19 ACCEPTANCE OF FINAL PAYMENT AS RELEASE

- a. The acceptance by the CONTRACTOR of final payment shall be and shall operate as a release to the OWNER of all claims and all liability to the CONTRACTOR other than claims in stated amounts as may be specifically expected by the CONTRACTOR for all things done or furnished in connection with the WORK and for every act and neglect of the OWNER and others relating to or arising out of the WORK. Any payment, however, final or otherwise, shall not release the CONTRACTOR or his sureties from any obligations under the CONTRACT DOCUMENTS or the Bonds.

20 INSURANCE

- a. The CONTRACTOR shall purchase and maintain such insurance as will protect him from claims set forth below which may arise out of or result from the CONTRACTOR's execution of the WORK, whether such execution be by him or by any SUBCONTRACTOR or by anyone directly or indirectly employed by any of them, or by anyone for whose acts any of them may be liable:
 - (1) Claims under worker's compensation, disability benefit and other similar employee benefit acts;
 - (2) Claims for damages because of bodily injury, occupational sickness or disease, or death of his employees;
 - (3) Claims for damages because of bodily injury, sickness or disease or death of any person other than his employees;
 - (4) Claims for damages insured by usual personal injury liability coverage which are sustained (a) by any person as a result of an offense directly or indirectly related to the employment of such person by the CONTRACTOR or (b) by any other person;
 - (5) Claims for damages because of injury to or destruction of tangible property, including loss of use resulting therefrom.
- b. Certificates of Insurance acceptable to the OWNER shall be filed with the OWNER prior to commencement of the WORK. These Certificates shall contain a provision that coverages afforded under the policies will not be canceled unless at least fifteen (15) days prior WRITTEN NOTICE has been given to the OWNER.
- c. The CONTRACTOR shall procure and maintain, at his own expense, during the CONTRACT TIME, liability insurance as hereinafter specified:
 - (1) CONTRACTOR's General Public Liability and Property Damage Insurance including vehicle coverage issued to the CONTRACTOR and protecting him from all claims for personal injury, including death, and all claims for destruction of or damage to property, arising out of or in connection with any operations under the CONTRACT DOCUMENTS, whether such operations be by him or by any SUBCONTRACTOR under him, or anyone directly or indirectly employed by the CONTRACTOR or by a SUBCONTRACTOR under him. Insurance shall be written with a limit of liability of not less than \$200,000.00 for all damages arising out of bodily injury, including death, at any time resulting therefor, sustained by any one person in any one accident; a limit of liability of not less than \$1,000,000.00 for any such damages sustained by two or more persons in any one accident. Insurance shall be written with a limit of liability of not less than \$100,000.00 for all property damage sustained by any one person in any one accident; and a limit of liability of not less than \$500,000.00 for any such damage sustained by two or more persons in any one accident.
 - (2) The CONTRACTOR shall acquire and maintain, if applicable, Fire and Extended Coverage insurance upon the PROJECT to the full insurable value thereof for the benefit of the OWNER, the CONTRACTOR and SUBCONTRACTORS as their interests may appear. This provision shall in no way release the CONTRACTOR or CONTRACTOR's surety from obligation under the CONTRACT DOCUMENTS to fully complete the PROJECT.
- d. The CONTRACTOR shall procure and maintain, at his own expense, during the CONTRACT TIME, in accordance with the provision of the laws of Oklahoma, Worker's Compensation Insurance, including occupational disease provisions, for all of his employees at the site of the

PROJECT and, in case any work is sublet, the CONTRACTOR shall require all SUBCONTRACTORS similarly to provide Worker's Compensation Insurance, including occupational disease provisions for all of the latter's employees unless such employees are covered by the protection afforded by the CONTRACTOR. In case any class of employees engaged in hazardous work under this contract at the site of the PROJECT is not protected under Worker's Compensation statute, the CONTRACTOR shall provide and shall cause each SUBCONTRACTOR to provide adequate and suitable insurance for the protection of his employees not otherwise protected.

- e. The CONTRACTOR shall secure, if applicable, "All Risk" type Builder's Risk Insurance for the WORK to be performed. Unless specifically authorized by the OWNER, the amount of such insurance shall not be less than the CONTRACT PRICE totaled in the BID. The policy shall cover not less than the losses due to fire, explosion, hail, lightning, vandalism, malicious mischief, wind, collapse, riot, aircraft and smoke during the CONTRACT TIME, and until the WORK is accepted by the OWNER. The policy shall name as insured the CONTRACTOR, the ENGINEER and the OWNER.

21 CONTRACT SECURITY

- a. The CONTRACTOR shall within ten (10) days after the receipt of the NOTICE OF AWARD furnish the OWNER with a Performance Bond and a Statutory Bond in penal sums equal to the amount of the CONTRACT PRICE, conditioned upon the performance by the CONTRACTOR of all undertakings, covenants, terms, conditions and agreements of the CONTRACT DOCUMENTS, and upon the prompt payment by the CONTRACTOR to all persons supplying labor and materials in the prosecution of the WORK provided by the CONTRACT DOCUMENTS. Such BONDS shall be executed by the CONTRACTOR and a corporate bonding company licensed to transact such business in the state in which the WORK is to be performed. The expense of these BONDS shall be borne by the CONTRACTOR. If at any time a surety on any such BOND is declared a bankrupt or loses its right to do business in the state in which the WORK is to be performed, CONTRACTOR shall within ten (10) days after notice from the OWNER to do so, substitute an acceptable BOND (or BONDS) in such form and sum signed by such other surety or sureties as may be satisfactory to the OWNER. The premiums on such BOND shall be paid by the CONTRACTOR. No further payments shall be deemed due nor shall be made until the new surety or sureties shall have furnished an acceptable BOND to the OWNER.

22 ASSIGNMENTS

- a. Neither the CONTRACTOR nor the OWNER shall sell, transfer, assign or otherwise dispose of the contract or any portion thereof, or of his right, title or interest therein, or his obligations thereunder, without written consent of the other party.

23 INDEMNIFICATION

- a. The CONTRACTOR will indemnify and hold harmless the OWNER and the ENGINEER and their agents and employees from and against all claims, damages, losses and expenses including attorneys' fees arising out of or resulting from the performance of the WORK provided that any such claims, damage, loss or expense is attributable to bodily injury, sickness, disease or death, or to injury to or destruction of tangible property, including the loss of use resulting therefrom; and is caused in whole or in part by any negligent or willful

act or omission of the CONTRACTOR, and/or SUBCONTRACTOR, anyone directly or indirectly employed by any of them or anyone for whose acts any of them may be liable.

- b. In any and all claims against the OWNER or the ENGINEER, or any of their agents or employees, by any employee of the CONTRACTOR, any SUBCONTRACTOR, anyone directly or indirectly employed by any of them or anyone for whose acts any of them may be liable, the indemnification obligation shall not be limited in any way by any limitation on the amount or type of damages, compensation or benefits payable by and for the CONTRACTOR or any SUBCONTRACTOR under worker's compensation acts, disability benefit acts or other employee benefit acts.
- c. The obligation of the CONTRACTOR under this paragraph shall not extend to the liability of the ENGINEER, his agents or employees arising out of the preparation or approval of maps, DRAWINGS, opinions, reports, surveys, CHANGE ORDERS, designs or SPECIFICATIONS.
- d. The OWNER is covered by the Oklahoma Tort Claims Act at 51 O.S. Sec. 151 *et seq.* Any claims for damages against the OWNER must be filed and comply with the requirement of the Oklahoma Tort Claims Act.

24 SEPARATE CONTRACTS

- a. The OWNER reserves the right to let other contracts in connection with this PROJECT. The CONTRACTOR shall afford other contractors reasonable opportunity for the introduction and storage of their materials and the execution of their work, and shall properly connect and coordinate his WORK with theirs. If the proper execution or results of any part of the CONTRACTOR's WORK depends upon the work of any other contractor, the CONTRACTOR shall inspect and promptly report to the ENGINEER any defects in such work that render it unsuitable for such proper execution and results.
- b. The OWNER may perform additional work related to the PROJECT, or it may let other contracts containing provisions similar to these. The CONTRACTOR will afford the other contractors who are parties to such contracts (or the OWNER, if it is performing the additional work itself) reasonable opportunity for the introduction and storage of materials and equipment and the execution of work, and shall properly connect and coordinate its WORK with theirs.
- c. If the performance of additional work by other contractors or the OWNER is not noted in the CONTRACT DOCUMENTS prior to the execution of the contract, written notice thereof shall be given to the CONTRACTOR prior to starting any such additional work. If the CONTRACTOR believes that the performance of such additional work by the OWNER or others involves him in additional expense or entitles him to an extension of the CONTRACT TIME, he may make a claim therefor as provided in Sections 13 and 14.

25 SUBCONTRACTING

- a. The CONTRACTOR may utilize the services of specialty SUBCONTRACTORS on those parts of the WORK that, under normal contracting practices, are performed by specialty SUBCONTRACTORS.
- b. The CONTRACTOR shall not award WORK to SUBCONTRACTOR(S) in excess of fifty percent (50%) of the CONTRACT PRICE, without prior written approval of the OWNER.

- c. The CONTRACTOR shall be fully responsible to the OWNER for the acts and omissions of his SUBCONTRACTORS, and of persons either directly or indirectly employed by them, as he is for the acts and omissions of persons directly employed by him.
- d. The CONTRACTOR shall cause appropriate provisions to be inserted in all subcontracts relative to the WORK to bind SUBCONTRACTORS to the CONTRACTOR by the terms of the CONTRACT DOCUMENTS insofar as applicable to the WORK of SUBCONTRACTORS and to give the CONTRACTOR the same power as regards terminating any subcontract that the OWNER may exercise over the CONTRACTOR under any provision of the CONTRACT DOCUMENTS.
- e. Nothing contained in this contract shall create any contractual relation between any SUBCONTRACTOR and the OWNER.
- f. The OWNER will not recognize any SUBCONTRACTOR on the WORK. The CONTRACTOR shall at all times when work is in progress be represented at the site either in person or by a qualified and approved superintendent who shall be in direct charge of all operations on the contract whether performed directly by the CONTRACTOR or the SUBCONTRACTOR.

26 ENGINEER'S AUTHORITY

- a. The ENGINEER shall act as the OWNER's representative during the construction period. He shall decide questions which may arise as to quality and acceptability of materials furnished and WORK performed. He shall interpret the intent of the CONTRACT DOCUMENTS in a fair and unbiased manner. The ENGINEER will make visits to the site and determine if the WORK is proceeding in accordance with the CONTRACT DOCUMENTS.
- b. The CONTRACTOR will be held strictly to the intent of the CONTRACT DOCUMENTS in regard to the quality of materials, workmanship and execution of the WORK. Inspections may be made at the factory or fabrication plant of the source of material supply.
- c. The ENGINEER will not be responsible for the construction means, controls, techniques, sequences, procedures or construction safety.
- d. The ENGINEER shall promptly make decisions relative to interpretation of the CONTRACT DOCUMENTS.

27 LAND AND RIGHTS-OF-WAY

- a. Prior to issuance of the NOTICE TO PROCEED, the OWNER shall obtain all land and rights-of-way necessary for carrying out and for the completion of the WORK to be performed pursuant to the CONTRACT DOCUMENTS, unless otherwise mutually agreed.
- b. The OWNER shall provide to the CONTRACTOR information which delineates and describes the lands owned and rights-of-way acquired.
- c. The CONTRACTOR shall provide at his own expense and without liability to the OWNER any additional land and access thereto that the CONTRACTOR may desire for temporary construction facilities or for storage of materials.

28 GUARANTY

- a. The CONTRACTOR shall guarantee all materials and equipment (including settlement or washing out of any backfill, leaks, etc.) furnished and WORK performed for a period of

two (2) years from the date of SUBSTANTIAL COMPLETION. The CONTRACTOR warrants and guarantees for a period of two (2) years from the date of SUBSTANTIAL COMPLETION of the WORK that the completed WORK is free from all defects due to faulty materials or workmanship and the CONTRACTOR shall promptly make such corrections as may be necessary by reason of such defects including the repairs of any damage to other parts of the WORK resulting from such defects. The OWNER will give notice of observed defects with reasonable promptness. In the event that the CONTRACTOR should fail to make such repairs, adjustments or other WORK that may be made necessary by such defects, the OWNER may do so and charge the CONTRACTOR the cost thereby incurred. The Performance Bond shall remain in full force and effect through the guarantee period.

29 GRADING AND CLEANING OF WORK SITE

- a. Before final acceptance of the WORK by the OWNER, the work site shall be graded in an approved manner. All rubbish, materials of construction, CONTRACTOR'S equipment, etc. shall be removed from the work site.
- b. Any privately owned facility (sprinkler lines, etc.) damaged by the CONTRACTOR, even located in the right of way, shall be replaced or repaired at the CONTRACTOR'S expense.

30 TESTING

- a. The City Engineer or his representative shall designate which samples must be taken or tests to be conducted and which must be taken or conducted in the presence of an inspector; the contractor must notify the inspector for all scheduled tests. The City Engineer may require such tests as he deems necessary to the proper construction of the project. All tests will be made in accordance with the appropriate specifications, ODOT or City of Midwest City as indicated in the contract and list of work or materials. The Contractor shall provide such facilities as the City Engineer or his representatives may require for collecting and forwarding samples. All tests shall be made at a laboratory designated by the City.
- b. All costs of tests on materials, which meet specifications shall be at the expense of the City.
- c. All costs of tests on materials, which fail to meet specifications, or that are required to prove acceptance due to failed tests, shall be at the expense of the Contractor. Also, any costs incurred by the City for cancelled tests which result in time charges shall be reimbursed to the City. All said costs shall be deducted from final pay applications.

SECTION C - CONSTRUCTION SPECIFICATIONS

GENERAL DESCRIPTION OF WORK

The work to be performed under the provisions of these contract documents consists of furnishing all materials, equipment, tools and plant; and the performance of all necessary labor and services to construct as shown in the Plans. Generally described as replacement of two air handlers and other HVAC equipment.

CONTRACT LENGTH

The contract length will be specified by the contractor on Bid, BID-2 at time of bid.

LIQUIDATED DAMAGES

Liquidated damages shall be assessed at the rate of one hundred dollars (\$100.00) per consecutive calendar day effective midnight on the last day of the contract as stated on the Notice to Proceed.

BASIS OF PAYMENT

The "Unit Prices" described herein shall be full compensation for all labor, materials, tools, equipment and incidentals necessary to complete the work in accordance with the plans and these specifications, and associated 2018 International Mechanical Code. All work not classified as a contract pay item shall be considered incidental construction and the cost for such shall be included in the price bid for other items of work.

MEASUREMENT AND PAYMENT

The method of measurement and basis of payment for each item listed in the bid shall be as stipulated in the following:

Under each item, the Contractor shall furnish, construct, and install in place all items as shown on the plans or as directed by the City.

FURTHER SPECIFICATIONS

The following sections comprise of these specifications for the associated work in the plans.

SECTION 23 0593 REPLACEMENT OF AIR HANDLER UNITS 6 & 8, TESTING, ADJUSTING,
AND BALANCING FOR HVAC

SECTION 23 0713 – DUCT INSULATION

SECTION 23 0719 - HVAC PIPING INSULATION

SECTION 23 2113 - HYDRONIC PIPING

SECTION 23 3113 - METAL DUCTS

SECTION 23 3300 - AIR DUCT ACCESSORIES

SECTION 23 7313 – INDOOR, SEMI-CUSTOM AIR-HANDLING UNITS

SECTION 23 8219 – FAN COIL UNITS

SECTION 26 0519 – LOW-VOLTAGE ELECTRICAL POWER CONDUCTORS AND CABLES

SECTION 26 0523 – CONTROL-VOLTAGE ELECTRICAL POWER CABLES

SECTION 26 0526 – GROUNDING AND BONDING FOR ELECTRICAL SYSTEMS

SECTION 26 0529 – HANGERS AND SUPPORTS FOR ELECTRICAL SYSTEMS

SECTION 26 0533 – RACEWAYS AND BOXES FOR ELECTRICAL SYSTEMS

SECTION 26 0553 – IDENTIFICATION FOR ELECTRICAL SYSTEMS

SECTION 26 2816 – ENCLOSED SWITCHES AND CIRCUIT BREAKERS

ITEM**NO. DESCRIPTION**

1. PUMP SYSTEM

Under this item, the Contractor will furnish all material, equipment, labor, etc. to replace the pump system according to the plans. This pay item will be in accordance with the plans and specifications.

Measurement - None

Payment - The contract lump sum for all work related to replacement of pumps as required for this project.

2. FAN COIL SYSTEM

Under this item, the Contractor will furnish all material, equipment, labor, etc. to replace the fan coil system according to the plans. This pay item will be in accordance with the plans and specifications.

Measurement - None

Payment - The contract lump sum for all work related to replacement of fan coil system as required for this project.

3. AHU 8

Under this item, the Contractor will furnish all material, equipment, labor, etc. to replace the AHU 8 (Air Handler Unit 8) according to the plans. This pay item will be in accordance with the plans and specifications.

Measurement - None

Payment - The contract lump sum for all work related to replacement of AHU 8 as required for this project.

4. AHU 6

Under this item, the Contractor will furnish all material, equipment, labor, etc. to replace the AHU 6 (Air Handler Unit 6) according to the plans. This pay item will be in accordance with the plans and specifications.

Measurement - None

Payment - The contract lump sum for all work related to replacement of AHU 8 as required for this project.

SECTION 23 0593 - REPLACEMENT OF AIR HANDLER UNITS 6 & 8, TESTING, ADJUSTING, AND BALANCING FOR HVAC

PART 1 GENERAL

1.01 RELATED DOCUMENTS

- A. Drawings and general provisions of the Contract, including General and Supplementary Conditions and Division 01 Specification Sections, apply to this Section.

1.02 SUMMARY

- A. Section Includes:
 - 1. Balancing Air Systems:
 - a. Constant-volume air systems.
 - 2. Balancing Hydronic Piping Systems:
 - a. Constant-flow hydronic systems.

1.03 DEFINITIONS

- A. AABC: Associated Air Balance Council.
- B. NEBB: National Environmental Balancing Bureau.
- C. TAB: Testing, adjusting, and balancing.
- D. TABB: Testing, Adjusting, and Balancing Bureau.
- E. TAB Specialist: An entity engaged to perform TAB Work.

1.04 INFORMATIONAL SUBMITTALS

- A. Qualification Data: Within 15 days of Contractor's Notice to Proceed, submit documentation that the TAB contractor and this Project's TAB team members meet the qualifications specified in "Quality Assurance" Article.
- B. Contract Documents Examination Report: Within 30 days of Contractor's Notice to Proceed, submit the Contract Documents review report as specified in Part 3.
- C. Strategies and Procedures Plan: Within 30 days of Contractor's Notice to Proceed, submit TAB strategies and step-by-step procedures as specified in "Preparation" Article.
- D. Certified TAB reports.
- E. Sample report forms.
- F. Instrument calibration reports, to include the following:
 - 1. Instrument type and make.
 - 2. Serial number.
 - 3. Application.
 - 4. Dates of use.
 - 5. Dates of calibration.

1.05 QUALITY ASSURANCE

- A. TAB Contractor Qualifications: Engage a TAB entity certified by AABC, NEBB, or TABB.
 - 1. TAB Field Supervisor: Employee of the TAB contractor and certified by AABC, NEBB, or TABB.
 - 2. TAB Technician: Employee of the TAB contractor and who is certified by AABC, NEBB, or TABB as a TAB technician.
- B. Certify TAB field data reports and perform the following:
 - 1. Review field data reports to validate accuracy of data and to prepare certified TAB reports.
 - 2. Certify that the TAB team complied with the approved TAB plan and the procedures specified and referenced in this Specification.
- C. TAB Report Forms: Use standard TAB contractor's forms approved by Architect.

- D. Instrumentation Type, Quantity, Accuracy, and Calibration: As described in ASHRAE 111, Section 5, "Instrumentation."
- E. ASHRAE Compliance: Applicable requirements in ASHRAE 62.1, Section 7.2.2 - "Air Balancing."
- F. ASHRAE/IESNA Compliance: Applicable requirements in ASHRAE/IESNA 90.1, Section 6.7.2.3 - "System Balancing."

PART 2 PRODUCTS (Not Applicable)

PART 3 EXECUTION

3.01 EXAMINATION

- A. Examine the Contract Documents to become familiar with Project requirements and to discover conditions in systems' designs that may preclude proper TAB of systems and equipment.
- B. Examine systems for installed balancing devices, such as test ports, gage cocks, thermometer wells, flow-control devices, balancing valves and fittings, and manual volume dampers. Verify that locations of these balancing devices are accessible.
- C. Examine the approved submittals for HVAC systems and equipment.
- D. Examine design data including HVAC system descriptions, statements of design assumptions for environmental conditions and systems' output, and statements of philosophies and assumptions about HVAC system and equipment controls.
- E. Examine ceiling plenums and underfloor air plenums used for supply, return, or relief air to verify that they meet the leakage class of connected ducts as specified in Section 233113 "Metal Ducts" and are properly separated from adjacent areas. Verify that penetrations in plenum walls are sealed and fire-stopped if required.
- F. Examine equipment performance data including fan and pump curves.
 - 1. Relate performance data to Project conditions and requirements, including system effects that can create undesired or unpredicted conditions that cause reduced capacities in all or part of a system.
 - 2. Calculate system-effect factors to reduce performance ratings of HVAC equipment when installed under conditions different from the conditions used to rate equipment performance. To calculate system effects for air systems, use tables and charts found in AMCA 201, "Fans and Systems," or in SMACNA's "HVAC Systems - Duct Design." Compare results with the design data and installed conditions.
- G. Examine system and equipment installations and verify that field quality-control testing, cleaning, and adjusting specified in individual Sections have been performed.
- H. Examine test reports specified in individual system and equipment Sections.
- I. Examine HVAC equipment and filters and verify that bearings are greased, belts are aligned and tight, and equipment with functioning controls is ready for operation.
- J. Examine heat-transfer coils for correct piping connections and for clean and straight fins.
- K. Examine operating safety interlocks and controls on HVAC equipment.
- L. Report deficiencies discovered before and during performance of TAB procedures. Observe and record system reactions to changes in conditions. Record default set points if different from indicated values.

3.02 PREPARATION

- A. Prepare a TAB plan that includes strategies and step-by-step procedures.
- B. Complete system-readiness checks and prepare reports. Verify the following:
 - 1. Airside:

- a. Permanent electrical-power wiring is complete.
 - b. Automatic temperature-control systems are operational.
 - c. Equipment and duct access doors are securely closed.
 - d. Balance, smoke, and fire dampers are open.
 - e. Ceilings are installed in critical areas where air-pattern adjustments are required and access to balancing devices is provided.
 - f. Windows and doors can be closed so indicated conditions for system operations can be met.
2. Hydronics:
- a. Control valves are functioning in accordance with the sequence of operation.
 - b. Shutoff and balance valves have been verified to be 100 percent open.
 - c. Pumps are started and proper rotation is verified.
 - d. Pump gauge connections are installed directly at pump inlet and outlet flanges or in discharge and suction pipe prior to valves or strainers.

3.03 GENERAL PROCEDURES FOR TESTING AND BALANCING

- A. Perform testing and balancing procedures on each system according to the procedures contained in AABC's "National Standards for Total System Balance" and in this Section.
 - 1. Comply with requirements in ASHRAE 62.1, Section 7.2.2 - "Air Balancing."
- B. Cut insulation, ducts, pipes, and equipment cabinets for installation of test probes to the minimum extent necessary for TAB procedures.
 - 1. After testing and balancing, patch probe holes in ducts with same material and thickness as used to construct ducts.
 - 2. Install and join new insulation that matches removed materials. Restore insulation, coverings, vapor barrier, and finish according to Section 230713 "Duct Insulation."
- C. Mark equipment and balancing devices, including damper-control positions, valve position indicators, fan-speed-control levers, and similar controls and devices, with paint or other suitable, permanent identification material to show final settings.
- D. Take and report testing and balancing measurements in inch-pound (IP) units.

3.04 GENERAL PROCEDURES FOR BALANCING AIR SYSTEMS

- A. Prepare test reports for both fans and outlets. Obtain manufacturer's outlet factors and recommended testing procedures. Crosscheck the summation of required outlet volumes with required fan volumes.
- B. Prepare schematic diagrams of systems' "as-built" duct layouts.
- C. Determine the best locations in main and branch ducts for accurate duct-airflow measurements.
- D. Check airflow patterns from the outdoor-air louvers and dampers and the return- and exhaust-air dampers through the supply-fan discharge and mixing dampers.
- E. Locate start-stop and disconnect switches, electrical interlocks, and motor starters.
- F. Verify that motor starters are equipped with properly sized thermal protection.
- G. Check dampers for proper position to achieve desired airflow path.
- H. Check for airflow blockages.
- I. Check condensate drains for proper connections and functioning.
- J. Check for proper sealing of air-handling-unit components.
- K. Verify that air duct system is sealed as specified in Section 233113 "Metal Ducts."

3.05 PROCEDURES FOR CONSTANT-VOLUME AIR SYSTEMS

- A. Adjust fans to deliver total indicated airflows within the maximum allowable fan speed listed by fan manufacturer.
 - 1. Measure total airflow.
 - a. Where sufficient space in ducts is unavailable for Pitot-tube traverse measurements,

- measure airflow at terminal outlets and inlets and calculate the total airflow.
2. Measure fan static pressures as follows to determine actual static pressure:
 - a. Measure outlet static pressure as far downstream from the fan as practical and upstream from restrictions in ducts such as elbows and transitions.
 - b. Measure static pressure directly at the fan outlet or through the flexible connection.
 - c. Measure inlet static pressure of single-inlet fans in the inlet duct as near the fan as possible, upstream from the flexible connection, and downstream from duct restrictions.
 - d. Measure inlet static pressure of double-inlet fans through the wall of the plenum that houses the fan.
 3. Measure static pressure across each component that makes up an air-handling unit, rooftop unit, and other air-handling and -treating equipment.
 - a. Report the cleanliness status of filters and the time static pressures are measured.
 4. Measure static pressures entering and leaving other devices, such as sound traps, heat-recovery equipment, and air washers, under final balanced conditions.
 5. Review Record Documents to determine variations in design static pressures versus actual static pressures. Calculate actual system-effect factors. Recommend adjustments to accommodate actual conditions.
 6. Obtain approval from Architect for adjustment of fan speed higher or lower than indicated speed. Comply with requirements in HVAC Sections for air-handling units for adjustment of fans, belts, and pulley sizes to achieve indicated air-handling-unit performance.
 7. Do not make fan-speed adjustments that result in motor overload. Consult equipment manufacturers about fan-speed safety factors. Modulate dampers and measure fan-motor amperage to ensure that no overload will occur. Measure amperage in full-cooling, full-heating, economizer, and any other operating mode to determine the maximum required brake horsepower.
- B. Adjust volume dampers for main duct, submain ducts, and major branch ducts to indicated airflows within specified tolerances.
1. Measure airflow of submain and branch ducts.
 - a. Where sufficient space in submain and branch ducts is unavailable for Pitot-tube traverse measurements, measure airflow at terminal outlets and inlets and calculate the total airflow for that zone.
 2. Measure static pressure at a point downstream from the balancing damper, and adjust volume dampers until the proper static pressure is achieved.
 3. Remeasure each submain and branch duct after all have been adjusted. Continue to adjust submain and branch ducts to indicated airflows within specified tolerances.
- C. Measure air outlets and inlets without making adjustments.
1. Measure terminal outlets using a direct-reading hood or outlet manufacturer's written instructions and calculating factors.
- D. Adjust air outlets and inlets for each space to indicated airflows within specified tolerances of indicated values. Make adjustments using branch volume dampers rather than extractors and the dampers at air terminals.
1. Adjust each outlet in same room or space to within specified tolerances of indicated quantities without generating noise levels above the limitations prescribed by the Contract Documents.
 2. Adjust patterns of adjustable outlets for proper distribution without drafts.
- 3.06 GENERAL PROCEDURES FOR HYDRONIC SYSTEMS
- A. Prepare test reports for pumps, coils, and other equipment. Obtain approved submittals and manufacturer-recommended testing procedures. Crosscheck the summation of required coil and equipment flow rates with pump design flow rate.
- B. Prepare schematic diagrams of systems' Record drawings piping layouts.

- C. In addition to requirements in "Preparation" Article, prepare hydronic systems for testing and balancing as follows:
 - 1. Check expansion tank for proper setting.
 - 2. Check highest vent for adequate pressure.
 - 3. Check flow-control valves for proper position.
 - 4. Locate start-stop and disconnect switches, electrical interlocks, and motor controllers.
 - 5. Verify that motor controllers are equipped with properly sized thermal protection.
 - 6. Check that air has been purged from the system.
- D. Measure and record upstream and downstream pressure of each piece of equipment.
- E. Measure and record upstream and downstream pressure of pressure-reducing valves.
- F. Check settings and operation of automatic temperature-control valves, self-contained control valves, and pressure-reducing valves. Record final settings.
 - 1. Check settings and operation of each safety valve. Record settings.

3.07 PROCEDURES FOR CONSTANT-FLOW HYDRONIC SYSTEMS

- A. Adjust pumps to deliver total design flow.
 - 1. Measure total water flow.
 - a. Position valves for full flow through coils.
 - b. Measure flow by main flow meter, if installed.
 - c. If main flow meter is not installed, determine flow by pump TDH or known equipment pressure drop.
 - 2. Measure pump TDH as follows:
 - a. Measure discharge pressure directly at the pump outlet flange or in discharge pipe prior to any valves.
 - b. Measure inlet pressure directly at the pump inlet flange or in suction pipe prior to any valves or strainers.
 - c. Convert pressure to head and correct for differences in gauge heights.
 - d. Verify pump impeller size by measuring the TDH with the discharge valve closed. Note the point on manufacturer's pump curve at zero flow, and verify that the pump has the intended impeller size.
 - e. With valves open, read pump TDH. Adjust pump discharge valve until design water flow is achieved. If excessive throttling is required to achieve desired flow, recommend pump impellers be trimmed to reduce excess throttling.
 - 3. Monitor motor performance during procedures, and do not operate motor in an overloaded condition.
- B. Adjust flow-measuring devices installed in mains and branches to design water flows.
 - 1. Measure flow in main and branch pipes.
 - 2. Adjust main and branch balance valves for design flow.
 - 3. Re-measure each main and branch after all have been adjusted.
- C. Adjust flow-measuring devices installed at terminals for each space to design water flows.
 - 1. Measure flow at terminals.
 - 2. Adjust each terminal to design flow.
 - 3. Re-measure each terminal after it is adjusted.
 - 4. Position control valves to bypass the coil, and adjust the bypass valve to maintain design flow.
 - 5. Perform temperature tests after flows have been balanced.
- D. For systems with pressure-independent valves at terminals:
 - 1. Measure differential pressure and verify that it is within manufacturer's specified range.
 - 2. Perform temperature tests after flows have been verified.
- E. For systems without pressure-independent valves or flow-measuring devices at terminals:
 - 1. Measure and balance coils by either coil pressure drop or temperature method.
 - 2. If balanced by coil pressure drop, perform temperature tests after flows have been

verified.

F. Verify final system conditions as follows:

1. Re-measure and confirm that total water flow is within design.
2. Re-measure final pumps' operating data, TDH, volts, amps, and static profile.
3. Mark final settings.

G. Verify that memory stops have been set.

3.08 TOLERANCES

A. Set HVAC system's air flow rates and water flow rates within the following tolerances:

1. Equipment with Fans: Plus or minus 10 percent.
2. Air Outlets and Inlets: Plus or minus 10 percent.
3. Exhaust fans: Plus 10 percent.
4. Outside air: Minus 10 percent.
5. Heating-Water Flow Rate: Plus or minus 5 percent.
6. Chilled-Water Flow Rate: Plus or minus 5 percent.
7. Condenser-Water Flow Rate: Plus or minus 5 percent.

3.09 PROGRESS REPORTING

- A. Initial Construction-Phase Report: Based on examination of the Contract Documents as specified in "Examination" Article, prepare a report on the adequacy of design for systems' balancing devices. Recommend changes and additions to systems' balancing devices to facilitate proper performance measuring and balancing. Recommend changes and additions to HVAC systems and general construction to allow access for performance measuring and balancing devices.
- B. Status Reports: Prepare weekly progress reports to describe completed procedures, procedures in progress, and scheduled procedures. Include a list of deficiencies and problems found in systems being tested and balanced. Prepare a separate report for each system and each building floor for systems serving multiple floors.

3.10 FINAL REPORT

- A. General: Prepare a certified written report; tabulate and divide the report into separate sections for tested systems and balanced systems.
1. Include a certification sheet at the front of the report's binder, signed and sealed by the certified testing and balancing engineer.
 2. Include a list of instruments used for procedures, along with proof of calibration.
- B. Final Report Contents: In addition to certified field-report data, include the following:
1. Fan curves.
 2. Pump curves
 3. Manufacturers' test data.
 4. Field test reports prepared by system and equipment installers.
 5. Other information relative to equipment performance; do not include Shop Drawings and product data.
- C. General Report Data: In addition to form titles and entries, include the following data:
1. Title page.
 2. Name and address of the TAB contractor.
 3. Project name.
 4. Project location.
 5. Architect's name and address.
 6. Engineer's name and address.
 7. Contractor's name and address.
 8. Report date.
 9. Signature of TAB supervisor who certifies the report.
 10. Table of Contents with the total number of pages defined for each section of the report.

- Number each page in the report.
11. Summary of contents including the following:
 - a. Indicated versus final performance.
 - b. Notable characteristics of systems.
 - c. Description of system operation sequence if it varies from the Contract Documents.
 12. Nomenclature sheets for each item of equipment.
 13. Data for terminal units, including manufacturer's name, type, size, and fittings.
 14. Notes to explain why certain final data in the body of reports vary from indicated values.
 15. Test conditions for fans and pump performance forms including the following:
 - a. Settings for outdoor-, return-, and exhaust-air dampers.
 - b. Conditions of filters.
 - c. Cooling coil, wet- and dry-bulb conditions.
 - d. Face and bypass damper settings at coils.
 - e. Fan drive settings including settings and percentage of maximum pitch diameter.
 - f. Inlet vane settings for variable-air-volume systems.
 - g. Settings for supply-air, static-pressure controller.
 - h. Other system operating conditions that affect performance.
- D. System Diagrams: Include schematic layouts of air and hydronic distribution systems. Present each system with single-line diagram and include the following:
1. Quantities of outdoor, supply, return, and exhaust airflows.
 2. Water and steam flow rates.
 3. Duct, outlet, and inlet sizes.
 4. Pipe and valve sizes and locations.
 5. Terminal units.
 6. Balancing stations.
 7. Position of balancing devices.
- E. Air-Handling-Unit Test Reports: For air-handling units with coils, include the following:
1. Unit Data:
 - a. Unit identification.
 - b. Location.
 - c. Make and type.
 - d. Model number and unit size.
 - e. Manufacturer's serial number.
 - f. Unit arrangement and class.
 - g. Discharge arrangement.
 - h. Sheave make, size in inches, and bore.
 - i. Center-to-center dimensions of sheave, and amount of adjustments in inches.
 - j. Number, make, and size of belts.
 - k. Number, type, and size of filters.
 2. Motor Data:
 - a. Motor make, and frame type and size.
 - b. Horsepower and rpm.
 - c. Volts, phase, and hertz.
 - d. Full-load amperage and service factor.
 - e. Sheave make, size in inches, and bore.
 - f. Center-to-center dimensions of sheave, and amount of adjustments in inches.
 3. Test Data (Indicated and Actual Values):
 - a. Total air flow rate in cfm.
 - b. Total system static pressure in inches wg.
 - c. Fan rpm.
 - d. Discharge static pressure in inches wg.
 - e. Filter static-pressure differential in inches wg.

- f. Preheat-coil static-pressure differential in inches wg.
 - g. Cooling-coil static-pressure differential in inches wg.
 - h. Heating-coil static-pressure differential in inches wg.
 - i. Outdoor airflow in cfm.
 - j. Return airflow in cfm.
 - k. Outdoor-air damper position.
 - l. Return-air damper position.
 - m. Vortex damper position.
- F. Apparatus-Coil Test Reports:
- 1. Coil Data:
 - a. System identification.
 - b. Location.
 - c. Coil type.
 - d. Number of rows.
 - e. Fin spacing in fins per inch o.c.
 - f. Make and model number.
 - g. Face area in sq. ft..
 - h. Tube size in NPS.
 - i. Tube and fin materials.
 - j. Circuiting arrangement.
 - 2. Test Data (Indicated and Actual Values):
 - a. Air flow rate in cfm.
 - b. Average face velocity in fpm.
 - c. Air pressure drop in inches wg.
 - d. Outdoor-air, wet- and dry-bulb temperatures in deg F.
 - e. Return-air, wet- and dry-bulb temperatures in deg F.
 - f. Entering-air, wet- and dry-bulb temperatures in deg F.
 - g. Leaving-air, wet- and dry-bulb temperatures in deg F.
 - h. Water flow rate in gpm.
 - i. Water pressure differential in feet of head or psig.
 - j. Entering-water temperature in deg F.
 - k. Leaving-water temperature in deg F.
 - l. Water flow rate in gpm
 - m. Water pressure differential in feet of head
 - n. Entering-water temperature in deg F
 - o. Leaving-water temperature in deg F
- G. Gas- and Oil-Fired Heat Apparatus Test Reports: In addition to manufacturer's factory startup equipment reports, include the following:
- 1. Unit Data:
 - a. System identification.
 - b. Location.
 - c. Make and type.
 - d. Model number and unit size.
 - e. Manufacturer's serial number.
 - f. Fuel type in input data.
 - g. Output capacity in Btu/h.
 - h. Ignition type.
 - i. Burner-control types.
 - j. Motor horsepower and rpm.
 - k. Motor volts, phase, and hertz.
 - l. Motor full-load amperage and service factor.
 - m. Sheave make, size in inches, and bore.

- n. Center-to-center dimensions of sheave, and amount of adjustments in inches.
- 2. Test Data (Indicated and Actual Values):
 - a. Total air flow rate in cfm.
 - b. Entering-air temperature in deg F.
 - c. Leaving-air temperature in deg F.
 - d. Air temperature differential in deg F.
 - e. Entering-air static pressure in inches wg.
 - f. Leaving-air static pressure in inches wg.
 - g. Air static-pressure differential in inches wg.
 - h. Low-fire fuel input in Btu/h.
 - i. High-fire fuel input in Btu/h.
 - j. Manifold pressure in psig.
 - k. High-temperature-limit setting in deg F.
 - l. Operating set point in Btu/h.
 - m. Motor voltage at each connection.
 - n. Motor amperage for each phase.
 - o. Heating value of fuel in Btu/h.
- H. Fan Test Reports: For supply, return, and exhaust fans, include the following:
 - 1. Fan Data:
 - a. System identification.
 - b. Location.
 - c. Make and type.
 - d. Model number and size.
 - e. Manufacturer's serial number.
 - f. Arrangement and class.
 - g. Sheave make, size in inches, and bore.
 - h. Center-to-center dimensions of sheave, and amount of adjustments in inches.
 - 2. Motor Data:
 - a. Motor make, and frame type and size.
 - b. Horsepower and rpm.
 - c. Volts, phase, and hertz.
 - d. Full-load amperage and service factor.
 - e. Sheave make, size in inches, and bore.
 - f. Center-to-center dimensions of sheave, and amount of adjustments in inches.
 - g. Number, make, and size of belts.
 - 3. Test Data (Indicated and Actual Values):
 - a. Total airflow rate in cfm.
 - b. Total system static pressure in inches wg.
 - c. Fan rpm.
 - d. Discharge static pressure in inches wg.
 - e. Suction static pressure in inches wg.
- I. Round, Flat-Oval, and Rectangular Duct Traverse Reports: Include a diagram with a grid representing the duct cross-section and record the following:
 - 1. Report Data:
 - a. System and air-handling-unit number.
 - b. Location and zone.
 - c. Traverse air temperature in deg F.
 - d. Duct static pressure in inches wg.
 - e. Duct size in inches.
 - f. Duct area in sq. ft.
 - g. Indicated air flow rate in cfm.
 - h. Indicated velocity in fpm.

- i. Actual air flow rate in cfm.
 - j. Actual average velocity in fpm.
 - k. Barometric pressure in psig.
- J. Instrument Calibration Reports:
- 1. Report Data:
 - a. Instrument type and make.
 - b. Serial number.
 - c. Application.
 - d. Dates of use.
 - e. Dates of calibration.

3.11 INSPECTIONS

- A. Initial Inspection:
- 1. After testing and balancing are complete, operate each system and randomly check measurements to verify that the system is operating according to the final test and balance readings documented in the final report.
 - 2. Check the following for each system:
 - a. Measure airflow of at least 10 percent of air outlets.
 - b. Measure room temperature at each thermostat/temperature sensor. Compare the reading to the set point.
 - c. Verify that balancing devices are marked with final balance position.
 - d. Note deviations from the Contract Documents in the final report.
- B. Final Inspection:
- 1. After initial inspection is complete and documentation by random checks verifies that testing and balancing are complete and accurately documented in the final report, request that a final inspection be made by Architect.
 - 2. The TAB contractor's test and balance engineer shall conduct the inspection in the presence of Architect.
 - 3. Architect shall randomly select measurements, documented in the final report, to be rechecked. Rechecking shall be limited to either 10 percent of the total measurements recorded or the extent of measurements that can be accomplished in a normal 8-hour business day.
 - 4. If rechecks yield measurements that differ from the measurements documented in the final report by more than the tolerances allowed, the measurements shall be noted as "FAILED."
 - 5. If the number of "FAILED" measurements is greater than 10 percent of the total measurements checked during the final inspection, the testing and balancing shall be considered incomplete and shall be rejected.
- C. TAB Work will be considered defective if it does not pass final inspections. If TAB Work fails, proceed as follows:
- 1. Recheck all measurements and make adjustments. Revise the final report and balancing device settings to include all changes; resubmit the final report and request a second final inspection.
 - 2. If the second final inspection also fails, Owner may contract the services of another TAB contractor to complete TAB Work according to the Contract Documents and deduct the cost of the services from the original TAB contractor's final payment.
- D. Prepare test and inspection reports.

3.12 ADDITIONAL TESTS

- A. Within 90 days of completing TAB, perform additional TAB to verify that balanced conditions are being maintained throughout and to correct unusual conditions.

END OF SECTION 23 0593

SECTION 23 0713 – DUCT INSULATION

PART 1 - GENERAL

1.01 SUMMARY

- A. Section includes insulating the following duct services:
 - 1. Indoor, concealed supply and outdoor air.
- B. Related Sections:
 - 1. Section 233113 "Metal Ducts" for duct liners.

1.02 ACTION SUBMITTALS

- A. Product Data: For each type of product indicated. Include thermal conductivity, water-vapor permeance thickness, and jackets (both factory- and field-applied if any).
- B. Shop Drawings: Include plans, elevations, sections, details, and attachments to other work.
 - 1. Detail application of protective shields, saddles, and inserts at hangers for each type of insulation and hanger.
 - 2. Detail insulation application at elbows, fittings, dampers, specialties and flanges for each type of insulation.
 - 3. Detail application of field-applied jackets.
 - 4. Detail application at linkages of control devices.

1.03 QUALITY ASSURANCE

- A. Installer Qualifications: Skilled mechanics who have successfully completed an apprenticeship program or another craft training program certified by the Department of Labor, Bureau of Apprenticeship and Training.
- B. Surface-Burning Characteristics: For insulation and related materials, as determined by testing identical products according to ASTM E 84, by a testing agency acceptable to authorities having jurisdiction. Factory label insulation and jacket materials and adhesive, mastic, tapes, and cement material containers, with appropriate markings of applicable testing agency.
 - 1. Insulation Installed Indoors: Flame-spread index of 25 or less, and smoke-developed index of 50 or less.
 - 2. Insulation Installed Outdoors: Flame-spread index of 75 or less, and smoke-developed index of 150 or less.

1.04 DELIVERY, STORAGE, AND HANDLING

- A. Packaging: Insulation material containers shall be marked by manufacturer with appropriate ASTM standard designation, type and grade, and maximum use temperature.

1.05 COORDINATION

- A. Coordinate clearance requirements with duct Installer for duct insulation application. Before preparing ductwork Shop Drawings, establish and maintain clearance requirements for installation of insulation and field-applied jackets and finishes and for space required for maintenance.

1.06 SCHEDULING

- A. Schedule insulation application after pressure testing systems and, where required, after installing and testing heat tracing. Insulation application may begin on segments that have satisfactory test results.
- B. Complete installation and concealment of plastic materials as rapidly as possible in each area of construction.

PART 2 - PRODUCTS

2.01 INSULATION MATERIALS

- A. Comply with requirements in "Duct Insulation Schedule, General," "Indoor Duct and Plenum Insulation Schedule," and "Aboveground, Outdoor Duct and Plenum Insulation Schedule" articles for where insulating materials shall be applied.
- B. Products shall not contain asbestos, lead, mercury, or mercury compounds.
- C. Products that come in contact with stainless steel shall have a leachable chloride content of less than 50 ppm when tested according to ASTM C 871.
- D. Insulation materials for use on austenitic stainless steel shall be qualified as acceptable according to ASTM C 795.
- E. Foam insulation materials shall not use CFC or HCFC blowing agents in the manufacturing process.
- F. Flexible Elastomeric Insulation: Closed-cell, sponge- or expanded-rubber materials. Comply with ASTM C 534, Type II for sheet materials.
- G. Mineral-Fiber Blanket Insulation: Mineral or glass fibers bonded with a thermosetting resin. Comply with ASTM C 553, Type II and ASTM C 1290, Type I. Factory-applied jacket requirements are specified in "Factory-Applied Jackets" Article.

2.02 ADHESIVES

- A. Materials shall be compatible with insulation materials, jackets, and substrates and for bonding insulation to itself and to surfaces to be insulated unless otherwise indicated.
- B. Flexible Elastomeric and Polyolefin Adhesive: Comply with MIL-A-24179A, Type II, Class I.
 - 1. For indoor applications, adhesive shall have a VOC content of 50 g/L or less when calculated according to 40 CFR 59, Subpart D (EPA Method 24).
 - 2. Adhesive shall comply with the testing and product requirements of the California Department of Health Services' "Standard Practice for the Testing of Volatile Organic Emissions from Various Sources Using Small-Scale Environmental Chambers."
- C. Mineral-Fiber Adhesive: Comply with MIL-A-3316C, Class 2, Grade A.
 - 1. For indoor applications, adhesive shall have a VOC content of 80 g/L or less when calculated according to 40 CFR 59, Subpart D (EPA Method 24).
 - 2. Adhesive shall comply with the testing and product requirements of the California Department of Health Services' "Standard Practice for the Testing of Volatile Organic Emissions from Various Sources Using Small-Scale Environmental Chambers."

- D. ASJ Adhesive, and FSK Jacket Adhesive: Comply with MIL-A-3316C, Class 2, Grade A for bonding insulation jacket lap seams and joints.
 - 1. For indoor applications, adhesive shall have a VOC content of 50 g/L or less when calculated according to 40 CFR 59, Subpart D (EPA Method 24).
 - 2. Adhesive shall comply with the testing and product requirements of the California Department of Health Services' "Standard Practice for the Testing of Volatile Organic Emissions from Various Sources Using Small-Scale Environmental Chambers."

2.03 MASTICS

- A. Materials shall be compatible with insulation materials, jackets, and substrates; comply with MIL-PRF-19565C, Type II.
 - 1. For indoor applications, use mastics that have a VOC content of 50 g/L or less when calculated according to 40 CFR 59, Subpart D (EPA Method 24).
- B. Vapor-Barrier Mastic: Water based; suitable for indoor use on below ambient services.
 - 1. Water-Vapor Permeance: ASTM E 96/E 96M, Procedure B, 0.013 perm at 43-mil dry film thickness.
 - 2. Service Temperature Range: Minus 20 to plus 180 deg F.
 - 3. Solids Content: ASTM D 1644, 58 percent by volume and 70 percent by weight.
 - 4. Color: White.
- C. Vapor-Barrier Mastic: Solvent based; suitable for indoor use on below ambient services.
 - 1. Water-Vapor Permeance: ASTM F 1249, 0.05 perm at 35-mil dry film thickness.
 - 2. Service Temperature Range: 0 to 180 deg F.
 - 3. Solids Content: ASTM D 1644, 44 percent by volume and 62 percent by weight.
 - 4. Color: White.

2.04 LAGGING ADHESIVES

- A. Description: Comply with MIL-A-3316C, Class I, Grade A and shall be compatible with insulation materials, jackets, and substrates.
 - 1. For indoor applications, use lagging adhesives that have a VOC content of 50 g/L or less when calculated according to 40 CFR 59, Subpart D (EPA Method 24).
 - 2. Fire-resistant, water-based lagging adhesive and coating for use indoors to adhere fire-resistant lagging cloths over duct insulation.
 - 3. Service Temperature Range: 0 to plus 180 deg F.
 - 4. Color: White.

2.05 SEALANTS

- A. FSK and Metal Jacket Flashing Sealants:
 - 1. Materials shall be compatible with insulation materials, jackets, and substrates.
 - 2. Fire- and water-resistant, flexible, elastomeric sealant.
 - 3. Service Temperature Range: Minus 40 to plus 250 deg F.
 - 4. Color: Aluminum.
 - 5. For indoor applications, sealants shall have a VOC content of 420 g/L or less when calculated according to 40 CFR 59, Subpart D (EPA Method 24).
 - 6. Sealants shall comply with the testing and product requirements of the California Department of Health Services' "Standard Practice for the Testing of Volatile Organic Emissions from Various Sources Using Small-Scale Environmental Chambers."

PART 3 - EXECUTION

3.01 EXAMINATION

- A. Examine substrates and conditions for compliance with requirements for installation tolerances and other conditions affecting performance of insulation application.
 - 1. Verify that systems to be insulated have been tested and are free of defects.
 - 2. Verify that surfaces to be insulated are clean and dry.
- B. Proceed with installation only after unsatisfactory conditions have been corrected.

3.02 PREPARATION

- A. Surface Preparation: Clean and dry surfaces to receive insulation. Remove materials that will adversely affect insulation application.

3.03 GENERAL INSTALLATION REQUIREMENTS

- A. Install insulation materials, accessories, and finishes with smooth, straight, and even surfaces; free of voids throughout the length of ducts and fittings.
- B. Install insulation materials, vapor barriers or retarders, jackets, and thicknesses required for each item of duct system as specified in insulation system schedules.
- C. Install accessories compatible with insulation materials and suitable for the service. Install accessories that do not corrode, soften, or otherwise attack insulation or jacket in either wet or dry state.
- D. Install insulation with longitudinal seams at top and bottom of horizontal runs.
- E. Install multiple layers of insulation with longitudinal and end seams staggered.
- F. Keep insulation materials dry during application and finishing.
- G. Install insulation with tight longitudinal seams and end joints. Bond seams and joints with adhesive recommended by insulation material manufacturer.
- H. Install insulation with least number of joints practical.
- I. Where vapor barrier is indicated, seal joints, seams, and penetrations in insulation at hangers, supports, anchors, and other projections with vapor-barrier mastic.
 - 1. Install insulation continuously through hangers and around anchor attachments.
 - 2. For insulation application where vapor barriers are indicated, extend insulation on anchor legs from point of attachment to supported item to point of attachment to structure. Taper and seal ends at attachment to structure with vapor-barrier mastic.
 - 3. Install insert materials and install insulation to tightly join the insert. Seal insulation to insulation inserts with adhesive or sealing compound recommended by insulation material manufacturer.
- J. Apply adhesives, mastics, and sealants at manufacturer's recommended coverage rate and wet and dry film thicknesses.
- K. Install insulation with factory-applied jackets as follows:
 - 1. Draw jacket tight and smooth.

2. Cover circumferential joints with 3-inch wide strips, of same material as insulation jacket. Secure strips with adhesive and outward clinching staples along both edges of strip, spaced 4 inches (100 mm) o.c.
 3. Overlap jacket longitudinal seams at least 1-1/2 inches. Clean and dry surface to receive self-sealing lap. Staple laps with outward clinching staples along edge at 2 inches o.c.
 - a. For below ambient services, apply vapor-barrier mastic over staples.
 4. Cover joints and seams with tape, according to insulation material manufacturer's written instructions, to maintain vapor seal.
 5. Where vapor barriers are indicated, apply vapor-barrier mastic on seams and joints and at ends adjacent to duct flanges and fittings.
- L. Cut insulation in a manner to avoid compressing insulation more than 75 percent of its nominal thickness.
- M. Finish installation with systems at operating conditions. Repair joint separations and cracking due to thermal movement.
- N. Repair damaged insulation facings by applying same facing material over damaged areas. Extend patches at least 4 inches beyond damaged areas. Adhere, staple, and seal patches similar to butt joints.

3.04 PENETRATIONS

- A. Insulation Installation at Roof Penetrations: Install insulation continuously through roof penetrations.
1. Seal penetrations with flashing sealant.
 2. For applications requiring only indoor insulation, terminate insulation above roof surface and seal with joint sealant. For applications requiring indoor and outdoor insulation, install insulation for outdoor applications tightly joined to indoor insulation ends. Seal joint with joint sealant.
 3. Extend jacket of outdoor insulation outside roof flashing at least 2 inches below top of roof flashing.
 4. Seal jacket to roof flashing with flashing sealant.
- B. Insulation Installation at Aboveground Exterior Wall Penetrations: Install insulation continuously through wall penetrations.
1. Seal penetrations with flashing sealant.
 2. For applications requiring only indoor insulation, terminate insulation inside wall surface and seal with joint sealant. For applications requiring indoor and outdoor insulation, install insulation for outdoor applications tightly joined to indoor insulation ends. Seal joint with joint sealant.
 3. Extend jacket of outdoor insulation outside wall flashing and overlap wall flashing at least 2 inches.
 4. Seal jacket to wall flashing with flashing sealant.
- C. Insulation Installation at Interior Wall and Partition Penetrations (That Are Not Fire Rated): Install insulation continuously through walls and partitions.
- D. Insulation Installation at Fire-Rated Wall and Partition Penetrations: Terminate insulation at fire damper sleeves for fire-rated wall and partition penetrations. Externally insulate damper sleeves to match adjacent insulation and overlap duct insulation at least 2 inches.
1. Comply with requirements in Section 078413 "Penetration Firestopping" firestopping and fire-resistive joint sealers.
- E. Insulation Installation at Floor Penetrations:

1. Duct: For penetrations through fire-rated assemblies, terminate insulation at fire damper sleeves and externally insulate damper sleeve beyond floor to match adjacent duct insulation. Overlap damper sleeve and duct insulation at least 2 inches (50 mm).
2. Seal penetrations through fire-rated assemblies. Comply with requirements in Section 078413 "Penetration Firestopping."

3.05 INSTALLATION OF FLEXIBLE ELASTOMERIC INSULATION

- A. Seal longitudinal seams and end joints with manufacturer's recommended adhesive to eliminate openings in insulation that allow passage of air to surface being insulated.

3.06 INSTALLATION OF MINERAL-FIBER INSULATION

- A. Blanket Insulation Installation on Ducts and Plenums: Secure with adhesive and insulation pins.
 1. Apply adhesives according to manufacturer's recommended coverage rates per unit area, for 100 percent coverage of duct and plenum surfaces.
 2. Apply adhesive to entire circumference of ducts and to all surfaces of fittings and transitions.
 3. Install either capacitor-discharge-weld pins and speed washers or cupped-head, capacitor-discharge-weld pins on sides and bottom of horizontal ducts and sides of vertical ducts as follows:
 - a. On duct sides with dimensions 18 inches and smaller, place pins along longitudinal centerline of duct. Space 3 inches maximum from insulation end joints, and 16 inches o.c.
 - b. On duct sides with dimensions larger than 18 inches, place pins 16 inches o.c. each way, and 3 inches maximum from insulation joints. Install additional pins to hold insulation tightly against surface at cross bracing.
 - c. Pins may be omitted from top surface of horizontal, rectangular ducts and plenums.
 - d. Do not overcompress insulation during installation.
 - e. Impale insulation over pins and attach speed washers.
 - f. Cut excess portion of pins extending beyond speed washers or bend parallel with insulation surface. Cover exposed pins and washers with tape matching insulation facing.
 4. For ducts and plenums with surface temperatures below ambient, install a continuous unbroken vapor barrier. Create a facing lap for longitudinal seams and end joints with insulation by removing 2 inches from one edge and one end of insulation segment. Secure laps to adjacent insulation section with 1/2-inch outward-clinching staples, 1 inch o.c. Install vapor barrier consisting of factory- or field-applied jacket, adhesive, vapor-barrier mastic, and sealant at joints, seams, and protrusions.
 - a. Repair punctures, tears, and penetrations with tape or mastic to maintain vapor-barrier seal.
 - b. Install vapor stops for ductwork and plenums operating below 50 deg at 18-foot intervals. Vapor stops shall consist of vapor-barrier mastic applied in a Z-shaped pattern over insulation face, along butt end of insulation, and over the surface. Cover insulation face and surface to be insulated a width equal to two times the insulation thickness, but not less than 3 inches.
 5. Overlap unfaced blankets a minimum of 2 inches on longitudinal seams and end joints. At end joints, secure with steel bands spaced a maximum of 18 inches o.c.
 6. Install insulation on rectangular duct elbows and transitions with a full insulation section for each surface. Install insulation on round and flat-oval duct elbows with individually mitered gores cut to fit the elbow.
 7. Insulate duct stiffeners, hangers, and flanges that protrude beyond insulation surface with 6-inch wide strips of same material used to insulate duct. Secure on alternating sides of stiffener, hanger, and flange with pins spaced 6 inches o.c.

3.07 DUCT INSULATION SCHEDULE, GENERAL

A. Plenums and Ducts Requiring Insulation:

1. Indoor, concealed supply and outdoor air.
2. Exhaust duct between the backdraft damper and building exterior.

B. Items Not Insulated:

1. Fibrous-glass ducts.
2. Metal ducts with duct liner of sufficient thickness to comply with energy code and ASHRAE/IESNA 90.1.
3. Factory-insulated flexible ducts.
4. Factory-insulated plenums and casings.
5. Flexible connectors.
6. Vibration-control devices.
7. Factory-insulated access panels and doors.

3.08 INDOOR DUCT AND PLENUM INSULATION SCHEDULE

A. Concealed, round and flat-oval, supply-air, outside air, and exhaust duct insulation shall be one of the following:

1. Flexible Elastomeric: 1 inch thick.
2. Mineral-Fiber Blanket: 1 inch thick and 0.75-lb/cu. ft. nominal density.

END OF SECTION 230713

SECTION 23 0719 - HVAC PIPING INSULATION

PART 1 GENERAL

1.01 SUMMARY

- A. Section includes insulation for HVAC piping systems.
- B. Related Requirements:
 - 1. Section 230713 "Duct Insulation" for duct insulation.
 - 2. Section 230716 "HVAC Equipment Insulation" for equipment insulation.

1.02 ACTION SUBMITTALS

- A. Product Data: For each type of product. Include thermal conductivity, water-vapor permeance thickness, and jackets (both factory and field applied, if any).
- B. Shop Drawings: Include plans, elevations, sections, details, and attachments to other work.
 - 1. Detail application of protective shields, saddles, and inserts at hangers for each type of insulation and hanger.
 - 2. Detail attachment and covering of heat tracing inside insulation.
 - 3. Detail insulation application at pipe expansion joints for each type of insulation.
 - 4. Detail insulation application at elbows, fittings, flanges, valves, and specialties for each type of insulation.
 - 5. Detail removable insulation at piping specialties.
 - 6. Detail application of field-applied jackets.
 - 7. Detail application at linkages of control devices.
- C. Samples: For each type of insulation and jacket indicated. Identify each Sample, describing product and intended use.
 - 1. Preformed Pipe Insulation Materials: 12 inches long by NPS 2.
 - 2. Sheet Form Insulation Materials: 12 inches square.
 - 3. Jacket Materials for Pipe: 12 inches long by NPS 2.
 - 4. Sheet Jacket Materials: 12 inches square.
 - 5. Manufacturer's Color Charts: For products where color is specified, show the full range of colors available for each type of finish material.

1.03 INFORMATIONAL SUBMITTALS

- A. Qualification Data: For qualified Installer.
- B. Material Test Reports: From a qualified testing agency acceptable to authorities having jurisdiction indicating, interpreting, and certifying test results for compliance of insulation materials, sealers, attachments, cements, and jackets, with requirements indicated. Include dates of tests and test methods employed.
- C. Field quality-control reports.

1.04 QUALITY ASSURANCE

- A. Installer Qualifications: Skilled mechanics who have successfully completed an apprenticeship program or craft training program, certified by the Department of Labor, or Bureau of Apprenticeship and Training.

1.05 DELIVERY, STORAGE, AND HANDLING

- A. Packaging: Insulation system materials are to be delivered to the Project site in unopened containers. The packaging is to include name of manufacturer, fabricator, type, description, and size.

1.06 COORDINATION

- A. Coordinate sizes and locations of supports, hangers, and insulation shields specified in Section 230529 "Hangers and Supports for HVAC Piping and Equipment."

- B. Coordinate clearance requirements with piping Installer for piping insulation application. Before preparing piping Shop Drawings, establish and maintain clearance requirements for installation of insulation and field-applied jackets and finishes and for space required for maintenance.

1.07 SCHEDULING

- A. Schedule insulation application after pressure testing systems and, where required, after installing and testing heat tracing. Insulation application may begin on segments that have satisfactory test results.

PART 2 PRODUCTS

2.01 PERFORMANCE REQUIREMENTS

- A. Surface-Burning Characteristics: For insulation and related materials, as determined by testing identical products in accordance with ASTM E84 by a testing agency acceptable to authority having jurisdiction. Factory label insulation, jacket materials, adhesive, mastic, tapes, and cement material containers with appropriate markings of applicable testing agency.
 - 1. All Insulation Installed Indoors: Flame-spread index of 25 or less, and smoke-developed index of 50 or less.

2.02 INSULATION MATERIALS

- A. Comply with requirements in "Piping Insulation Schedule, General," "Indoor Piping Insulation Schedule," "Outdoor, Aboveground Piping Insulation Schedule," and "Outdoor, Underground Piping Insulation Schedule" articles for where insulating materials are applied.
- B. Products do not contain asbestos, lead, mercury, or mercury compounds.
- C. Products that come into contact with stainless steel have a leachable chloride content of less than 50 ppm when tested in accordance with ASTM C871.
- D. Insulation materials for use on austenitic stainless steel are qualified as acceptable in accordance with ASTM C795.
- E. Foam insulation materials do not use CFC or HCFC blowing agents in the manufacturing process.
- F. Calcium Silicate: Preformed Pipe Sections: Flat-, curved-, and grooved-block sections of noncombustible, inorganic, hydrous calcium silicate with a non-asbestos fibrous reinforcement. Comply with ASTM C533, Type I.
 - 1. Prefabricated Fitting Covers: Comply with ASTM C450 and ASTM C585 for dimensions used in preforming insulation to cover valves, elbows, tees, and flanges.
- G. Cellular Glass: Inorganic, incombustible, foamed or cellulated glass with annealed, rigid, hermetically sealed cells. Comply with ASTM C552.
 - 1. Preformed Pipe Insulation without Jacket: Type II, Class 1, unfaced.
 - 2. Preformed Pipe Insulation with Jacket: Type II, Class 2, with factory-applied ASJ, ASJ-SSL, or ASJ+ jacket.
 - 3. Fabricated shapes in accordance with ASTM C450, ASTM C585, and ASTM C1639.
 - 4. Factory-applied jacket requirements are specified in "Factory-Applied Jackets" Article.
- H. Flexible Elastomeric: Closed-cell, or expanded-rubber materials; suitable for maximum use temperature between minus 70 deg F and 220 deg F. Comply with ASTM C534/C534M, Type I, for tubular materials, Type II for sheet materials.
- I. Glass-Fiber, Preformed Pipe: Glass fibers bonded with a thermosetting resin; suitable for maximum use temperature up to 850 deg F in accordance with ASTM C411. Comply with ASTM C547.
 - 1. Preformed Pipe Insulation: Type I, Grade A, unfaced with factory-applied ASJ, ASJ-SSL, or ASJ+ jacket.
 - 2. Fabricated shapes in accordance with ASTM C450 and ASTM C585.
 - 3. Factory-applied jacket requirements are specified in "Factory-Applied Jackets" Article.

- J. Glass-Fiber, Pipe and Tank: Glass fibers bonded with a thermosetting resin; suitable for maximum use temperature between 35 deg F and 850 deg F, in accordance with ASTM C411. Comply with ASTM C1393.
 - 1. Semirigid board material with factory-applied ASJ, FSK, or ASJ+ jacket.
 - 2. Factory-applied jacket requirements are specified in "Factory-Applied Jackets" Article.

2.03 INSULATING CEMENTS

- A. Glass-Fiber and Mineral Wool Insulating Cement: Comply with ASTM C195.
- B. Expanded or Exfoliated Vermiculite Insulating Cement: Comply with ASTM C196.
- C. Glass-Fiber and Mineral Wool Hydraulic-Setting Insulating and Finishing Cement: Comply with ASTM C449.

2.04 ADHESIVES

- A. Materials are compatible with insulation materials, jackets, and substrates and for bonding insulation to itself and to surfaces to be insulated unless otherwise indicated.
- B. Calcium Silicate Adhesive: Fibrous, sodium-silicate-based adhesive with a service temperature range of 50 to 800 deg F.
- C. Cellular-Glass Adhesive: Two-component, thermosetting urethane adhesive containing no flammable solvents, with a service temperature range of minus 100 to plus 200 deg F.
- D. Flexible Elastomeric and Polyolefin Adhesive: Solvent-based adhesive.
 - 1. Flame-spread index is 25 or less and smoke-developed index is 50 or less as tested in accordance with ASTM E84.
 - 2. Wet Flash Point: Below 0 deg F.
 - 3. Service Temperature Range: 40 to 200 deg F.
 - 4. Color: Black.
- E. Glass-Fiber and Mineral Wool Adhesive: Comply with MIL-A-3316C, Class 2, Grade A.
- F. ASJ Adhesive and FSK and PVDC Jacket Adhesive: Comply with MIL-A-3316C, Class 2, Grade A, for bonding insulation jacket lap seams and joints.
- G. PVC Jacket Adhesive: Compatible with PVC jacket.

2.05 MASTICS AND COATINGS

- A. Materials are compatible with insulation materials, jackets, and substrates.
- B. Vapor-Retarder Mastic, Water Based: Suitable for indoor use on below-ambient services.
 - 1. Water-Vapor Permeance: Comply with ASTM E96/E96M or ASTM F1249.
 - 2. Service Temperature Range: 0 to plus 180 deg F.
 - 3. Comply with MIL-PRF-19565C, Type II, for permeance requirements, with supplier listing on DOD QPD - Qualified Products Database.
 - 4. Color: White.
- C. Vapor-Retarder Mastic, Solvent Based, Indoor Use: Suitable for indoor use on below-ambient services.
 - 1. Water-Vapor Permeance: Comply with ASTM E96/E96M or ASTM F1249.
 - 2. Service Temperature Range: 0 to 180 deg F.
 - 3. Color: White.
- D. Vapor-Retarder Mastic, Solvent Based, Outdoor Use: Suitable for outdoor use on below-ambient services.
 - 1. Water-Vapor Permeance: Comply with ASTM E96/E96M or ASTM F1249.
 - 2. Service Temperature Range: Minus 50 to plus 220 deg F.
 - 3. Color: White.
- E. Breather Mastic: Water based; suitable for indoor and outdoor use on above-ambient services.
 - 1. Water-Vapor Permeance: ASTM E96/E96M, greater than 1.0 perm at manufacturer's recommended dry film thickness.

2. Service Temperature Range: 0 to plus 180 deg F.
3. Color: White.

2.06 LAGGING ADHESIVES

- A. Adhesives comply with MIL-A-3316C, Class I, Grade A, and are compatible with insulation materials, jackets, and substrates.
 1. Fire-resistant, water-based lagging adhesive and coating for use indoors to adhere fire-resistant lagging cloths over pipe insulation.
 2. Service Temperature Range: 0 to plus 180 deg F.
 3. Color: White.

2.07 SEALANTS

- A. Materials are as recommended by the insulation manufacturer and are compatible with insulation materials, jackets, and substrates.
- B. Joint Sealants:
 1. Permanently flexible, elastomeric sealant.
 - a. Service Temperature Range: Minus 150 to plus 250 deg F.
 - b. Color: White or gray.
- C. FSK and Metal Jacket Flashing Sealants:
 1. Fire- and water-resistant, flexible, elastomeric sealant.
 2. Service Temperature Range: Minus 40 to plus 250 deg F.
 3. Color: Aluminum.
- D. ASJ Flashing Sealants and PVDC and PVC Jacket Flashing Sealants:
 1. Fire- and water-resistant, flexible, elastomeric sealant.
 2. Service Temperature Range: Minus 40 to plus 250 deg F.
 3. Color: White.

2.08 FACTORY-APPLIED JACKETS

- A. Insulation system schedules indicate factory-applied jackets on various applications. When factory-applied jackets are indicated, comply with the following:
 1. ASJ: White, kraft-paper, fiberglass-reinforced scrim with aluminum-foil backing; complying with ASTM C1136, Type I.
 2. ASJ-SSL: ASJ with self-sealing, pressure-sensitive, acrylic-based adhesive covered by a removable protective strip; complying with ASTM C1136, Type I.
 3. FSK Jacket: Aluminum-foil, fiberglass-reinforced scrim with kraft-paper backing; complying with ASTM C1136, Type II.
 4. ASJ+: Aluminum foil reinforced with glass scrim bonded to a kraft paper interleaving with an outer film leaving no paper exposed; complying with ASTM C1136, Types I, II, III, IV, and VII.

2.09 FIELD-APPLIED JACKETS

- A. Field-applied jackets comply with ASTM C1136, Type I, unless otherwise indicated.
- B. FSK Jacket: Aluminum-foil-face, fiberglass-reinforced scrim with kraft-paper backing.
- C. PVC Jacket: High-impact-resistant, UV-resistant PVC complying with ASTM D1784, Class 16354-C; thickness as scheduled; roll stock ready for shop or field cutting and forming. Thickness is indicated in field-applied jacket schedules.
 1. Adhesive: As recommended by jacket material manufacturer.
 2. Color: Color-code jackets based on system. Color as selected by Architect.
 3. Factory-fabricated fitting covers to match jacket if available; otherwise, field fabricate.
 - a. Shapes: 45- and 90-degree, short- and long-radius elbows, tees, valves, flanges, unions, reducers, end caps, soil-pipe hubs, traps, mechanical joints, and P-trap and supply covers for lavatories.

2.10 TAPES

- A. ASJ Tape: White vapor-retarder tape matching factory-applied jacket with acrylic adhesive, complying with ASTM C1136.
 - 1. Width: 3 inches.
 - 2. Thickness: 11.5 mils.
 - 3. Adhesion: 90 ounces force/inch in width.
 - 4. Elongation: 2 percent.
 - 5. Tensile Strength: 40 lbf/inch in width.
 - 6. ASJ Tape Disks and Squares: Precut disks or squares of ASJ tape.
- B. FSK Tape: Foil-face, vapor-retarder tape matching factory-applied jacket with acrylic adhesive; complying with ASTM C1136.
 - 1. Width: 3 inches.
 - 2. Thickness: 6.5 mil.
 - 3. Adhesion: 90 ounces force/inch in width.
 - 4. Elongation: 2 percent.
 - 5. Tensile Strength: 40 lbf/inch in width.
 - 6. FSK Tape Disks and Squares: Precut disks or squares of FSK tape.
- C. PVC Tape: White vapor-retarder tape matching field-applied PVC jacket with acrylic adhesive; suitable for indoor and outdoor applications.
 - 1. Width: 2 inches.
 - 2. Thickness: 6 mils.
 - 3. Adhesion: 64 ounces force/inch in width.
 - 4. Elongation: 500 percent.
 - 5. Tensile Strength: 18 lbf/inch in width.

2.11 SECUREMENTS

- A. Bands:
 - 1. Stainless Steel: ASTM A240/A240M, Type 304 or Type 316; 0.015 inch thick, 1/2 inch wide with wing seal or closed seal.
 - 2. Aluminum: ASTM B209, Alloy 3003, 3005, 3105, or 5005; Temper H-14, 0.020 inch thick, 1/2 inch wide with wing seal or closed seal.
- B. Staples: Outward-clinching insulation staples, nominal 3/4 inch wide, stainless steel or Monel.
- C. Wire: 0.080-inch nickel-copper alloy.

PART 3 EXECUTION

3.01 EXAMINATION

- A. Examine substrates and conditions for compliance with requirements for installation tolerances and other conditions affecting performance of insulation application.
 - 1. Verify that systems to be insulated have been tested and are free of defects.
 - 2. Verify that surfaces to be insulated are clean and dry.
- B. Proceed with installation only after unsatisfactory conditions have been corrected.

3.02 PREPARATION

- A. Clean and dry surfaces to receive insulation. Remove materials that will adversely affect insulation application.
- B. Coordinate insulation installation with the tradesman installing heat tracing. Comply with requirements for heat tracing that apply to insulation.
- C. Mix insulating cements with clean potable water; if insulating cements are to be in contact with stainless steel surfaces, use demineralized water.

3.03 GENERAL INSTALLATION REQUIREMENTS

- A. Install insulation materials, accessories, and finishes with smooth, straight, and even surfaces; free of voids throughout the length of piping, including fittings, valves, and specialties.
- B. Install insulation materials, forms, vapor barriers or retarders, jackets, and of thicknesses required for each item of pipe system, as specified in insulation system schedules.
- C. Install accessories compatible with insulation materials and suitable for the service. Install accessories that do not corrode, compress, or otherwise damage insulation or jacket.
- D. Install insulation with longitudinal seams at top and bottom (12 o'clock and 6 o'clock positions) of horizontal runs.
- E. Install multiple layers of insulation with longitudinal and end seams staggered.
- F. Do not weld brackets, clips, or other attachment devices to piping, fittings, and specialties.
- G. Keep insulation materials dry during storage, application, and finishing. Replace insulation materials that get wet during storage or in the installation process before being properly covered and sealed in accordance with the Contract Documents.
- H. Install insulation with tight longitudinal seams and end joints. Bond seams and joints with adhesive recommended by insulation material manufacturer.
- I. Install insulation with least number of joints practical.
- J. Where vapor barrier is indicated, seal joints, seams, and penetrations in insulation at hangers, supports, anchors, and other projections with vapor-barrier mastic.
 - 1. Install insulation continuously through hangers and around anchor attachments.
 - 2. For insulation application where vapor barriers are indicated, extend insulation on anchor legs from point of attachment to supported item to point of attachment to structure. Taper and seal ends attached to structure with vapor-barrier mastic.
 - 3. Install insert materials and insulation to tightly join the insert. Seal insulation to insulation inserts with adhesive or sealing compound recommended by insulation material manufacturer.
 - 4. Cover inserts with jacket material matching adjacent pipe insulation. Install shields over jacket, arranged to protect jacket from tear or puncture by hanger, support, and shield.
- K. Apply adhesives, mastics, and sealants at manufacturer's recommended coverage rate and wet and dry film thicknesses.
- L. Install insulation with factory-applied jackets as follows:
 - 1. Draw jacket tight and smooth, but not to the extent of creating wrinkles or areas of compression in the insulation.
 - 2. Cover circumferential joints with 3-inch- wide strips, of same material as insulation jacket. Secure strips with adhesive and outward-clinching staples along both edges of strip, spaced 4 inches o.c.
 - 3. Overlap jacket longitudinal seams at least 1-1/2 inches. Install insulation with longitudinal seams at bottom of pipe. Clean and dry surface to receive self-sealing lap. Staple laps with outward-clinching staples along edge at 2 inches o.c.
 - 4. For below-ambient services, apply vapor-barrier mastic over staples.
 - 5. Cover joints and seams with tape, in accordance with insulation material manufacturer's written instructions, to maintain vapor seal.
 - 6. Where vapor barriers are indicated, apply vapor-barrier mastic on seams and joints and at ends adjacent to pipe flanges and fittings.
- M. Cut insulation in a manner to avoid compressing insulation.
- N. Finish installation with systems at operating conditions. Repair joint separations and cracking due to thermal movement.
- O. Repair damaged insulation facings by applying same facing material over damaged areas. Extend patches at least 4 inches beyond damaged areas. Adhere, staple, and seal patches in similar fashion to butt joints.

- P. For above-ambient services, do not install insulation to the following:
 - 1. Vibration-control devices.
 - 2. Testing agency labels and stamps.
 - 3. Nameplates and data plates.

3.04 PENETRATIONS

- A. Insulation Installation at Roof Penetrations: Install insulation continuously through roof penetrations.
 - 1. Seal penetrations with flashing sealant.
 - 2. For applications requiring only indoor insulation, terminate insulation above roof surface and seal with joint sealant. For applications requiring indoor and outdoor insulation, install insulation for outdoor applications tightly joined to indoor insulation ends. Seal joint with joint sealant.
 - 3. Extend jacket of outdoor insulation outside roof flashing at least 2 inches below top of roof flashing.
 - 4. Seal jacket to roof flashing with flashing sealant.
- B. Insulation Installation at Underground Exterior Wall Penetrations: Terminate insulation flush with sleeve seal. Seal terminations with flashing sealant.
- C. Insulation Installation at Aboveground Exterior Wall Penetrations: Install insulation continuously through wall penetrations.
 - 1. Seal penetrations with flashing sealant.
 - 2. For applications requiring only indoor insulation, terminate insulation inside wall surface and seal with joint sealant. For applications requiring indoor and outdoor insulation, install insulation for outdoor applications tightly joined to indoor insulation ends. Seal joint with joint sealant.
 - 3. Extend jacket of outdoor insulation outside wall flashing and overlap wall flashing at least 2 inches.
 - 4. Seal jacket to wall flashing with flashing sealant.
- D. Insulation Installation at Interior Wall and Partition Penetrations (That Are Not Fire Rated): Install insulation continuously through walls and partitions.
- E. Insulation Installation at Fire-Rated Wall and Partition Penetrations: Install insulation continuously through penetrations of fire-rated walls and partitions.
 - 1. Comply with requirements in Section 078413 "Penetration Firestopping" for firestopping and fire-resistive joint sealers.
- F. Insulation Installation at Floor Penetrations:
 - 1. Pipe: Install insulation continuously through floor penetrations.
 - 2. Seal penetrations through fire-rated assemblies. Comply with requirements in Section 078413 "Penetration Firestopping."

3.05 GENERAL PIPE INSULATION INSTALLATION

- A. Requirements in this article generally apply to all insulation materials, except where more specific requirements are specified in various pipe insulation material installation articles below.
- B. Insulation Installation on Fittings, Valves, Strainers, Flanges, Mechanical Couplings, and Unions:
 - 1. Install insulation over fittings, valves, strainers, flanges, mechanical couplings, unions, and other specialties with continuous thermal and vapor-retarder integrity unless otherwise indicated.
 - 2. Insulate pipe elbows using prefabricated fitting insulation made from same material and density as that of adjacent pipe insulation. Each piece is butted tightly against adjoining piece and bonded with adhesive. Fill joints, seams, voids, and irregular surfaces with insulating cement finished to a smooth, hard, and uniform contour that is uniform with adjoining pipe insulation.
 - 3. Insulate tee fittings with prefabricated fitting insulation of same material and thickness as

that used for adjacent pipe. Cut sectional pipe insulation to fit. Butt each section closely to the next and hold in place with tie wire. Bond pieces with adhesive.

4. Insulate valves using prefabricated fitting insulation of same material, density, and thickness as that used for adjacent pipe. Overlap adjoining pipe insulation by not less than 2 times the thickness of pipe insulation, or one pipe diameter, whichever is thicker. For valves, insulate up to and including the bonnets, valve stuffing-box studs, bolts, and nuts. Fill joints, seams, and irregular surfaces with insulating cement.
 5. Insulate strainers using prefabricated fitting insulation of same material, density, and thickness as that used for adjacent pipe. Overlap adjoining pipe insulation by not less than 2 times the thickness of pipe insulation, or one pipe diameter, whichever is thicker. Fill joints, seams, and irregular surfaces with insulating cement. Insulate strainers, so strainer basket flange or plug can be easily removed and replaced without damaging the insulation and jacket. Provide a removable reusable insulation cover. For below-ambient services, provide a design that maintains vapor barrier.
 6. Insulate flanges, mechanical couplings, and unions using a section of oversized preformed pipe insulation to fit. Overlap adjoining pipe insulation by not less than 2 times the thickness of pipe insulation, or one pipe diameter, whichever is thicker. Stencil or label the outside insulation jacket of each union with the word "union" matching size and color of pipe labels.
 7. Cover segmented insulated surfaces with a layer of finishing cement and coat with a mastic. Install vapor-barrier mastic for below-ambient services and a breather mastic for above-ambient services. Reinforce the mastic with reinforcing mesh. Trowel the mastic to a smooth and well-shaped contour.
 8. For services not specified to receive a field-applied jacket, except for flexible elastomeric and polyolefin, install fitted PVC cover over elbows, tees, strainers, valves, flanges, and unions. Terminate ends with PVC end caps. Tape PVC covers to adjoining insulation facing, using PVC tape.
- C. Insulate instrument connections for thermometers, pressure gages, pressure temperature taps, test connections, flow meters, sensors, switches, and transmitters on insulated pipes. Shape insulation at these connections by tapering it to and around the connection with insulating cement and finish with finishing cement, mastic, and flashing sealant.
- D. Install removable insulation covers. Installation conforms to the following:
1. Make removable flange and union insulation from sectional pipe insulation of same thickness as that on adjoining pipe. Install same insulation jacket as that of adjoining pipe insulation.
 2. When flange and union covers are made from sectional pipe insulation, extend insulation from flanges or union at least 2 times the insulation thickness over adjacent pipe insulation on each side of flange or union. Secure flange cover in place with stainless steel or aluminum bands. Select band material compatible with insulation and jacket.
 3. Construct removable valve insulation covers in same manner as for flanges, except divide the two-part section on the vertical center line of valve body.
 4. When covers are made from block insulation, make two halves, each consisting of mitered blocks wired to stainless steel fabric. Secure this wire frame, with its attached insulation, to flanges with tie wire. Extend insulation at least 2 inches over adjacent pipe insulation on each side of valve. Fill space between flange or union cover and pipe insulation with insulating cement. Finish cover assembly with insulating cement applied in two coats. After first coat is dry, apply and trowel second coat to a smooth finish.
 5. Unless a PVC jacket is indicated in field-applied jacket schedules, finish exposed surfaces with a metal jacket.

3.06 INSTALLATION OF CELLULAR-GLASS INSULATION

- A. Insulation Installation on Straight Pipes and Tubes:
1. Secure each layer of insulation to pipe with wire or bands, and tighten bands without deforming insulation materials.
 2. Where vapor barriers are indicated, seal longitudinal seams, end joints, and protrusions

- with vapor-barrier mastic and joint sealant.
3. For insulation with jackets on above-ambient services, secure laps with outward-clinched staples at 6 inches o.c.
 4. For insulation with jackets on below-ambient services, do not staple longitudinal tabs. Instead, secure tabs with additional adhesive, as recommended by insulation material manufacturer, and seal with vapor-barrier mastic and flashing sealant.
- B. Insulation Installation on Pipe Flanges:
1. Install prefabricated pipe insulation to outer diameter of pipe flange.
 2. Make width of insulation section same as overall width of flange and bolts, plus twice the thickness of pipe insulation.
 3. Fill voids between inner circumference of flange insulation and outer circumference of adjacent straight pipe segments with cut sections of cellular-glass block insulation of same thickness as that of pipe insulation. Where voids are difficult to fill with block insulation, fill the voids with a fibrous insulation material suitable for the specific operating temperature.
 4. Install jacket material with manufacturer's recommended adhesive, overlap seams at least 1 inch, and seal joints with flashing sealant.
- C. Insulation Installation on Pipe Fittings and Elbows:
1. Install prefabricated sections of same material as that of straight segments of pipe insulation when available. Secure according to manufacturer's written instructions.
 2. When preformed sections of insulation are not available, install mitered or routed sections of cellular-glass insulation. Secure insulation materials with wire or bands.
- D. Insulation Installation on Valves and Pipe Specialties:
1. Install prefabricated sections of cellular-glass insulation to valve body.
 2. Arrange insulation to permit access to packing and to allow valve operation without disturbing insulation.
 3. Install insulation to flanges as specified for flange insulation application.

3.07 INSTALLATION OF FLEXIBLE ELASTOMERIC INSULATION

- A. Seal longitudinal seams and end joints with manufacturer's recommended adhesive to eliminate openings in insulation that allow passage of air to surface being insulated.
- B. Insulation Installation on Pipe Flanges:
1. Install pipe insulation to outer diameter of pipe flange.
 2. Make width of insulation section same as overall width of flange and bolts, plus twice the thickness of pipe insulation.
 3. Fill voids between inner circumference of flange insulation and outer circumference of adjacent straight pipe segments with cut sections of sheet insulation of same thickness as that of pipe insulation.
 4. Secure insulation to flanges and seal seams with manufacturer's recommended adhesive to eliminate openings in insulation that allow passage of air to surface being insulated.
- C. Insulation Installation on Pipe Fittings and Elbows:
1. Install sections of pipe insulation and miter if required in accordance with manufacturer's written instructions.
 2. Secure insulation materials and seal seams with manufacturer's recommended adhesive to eliminate openings in insulation that allow passage of air to surface being insulated.
- D. Insulation Installation on Valves and Pipe Specialties:
1. Install prefabricated valve covers manufactured of same material as that of pipe insulation when available.
 2. When prefabricated valve covers are not available, install cut sections of pipe and sheet insulation to valve body. Arrange insulation to permit access to packing and to allow valve operation without disturbing insulation.
 3. Install insulation to flanges as specified for flange insulation application.
 4. Secure insulation to valves and specialties, and seal seams with manufacturer's

recommended adhesive to eliminate openings in insulation that allow passage of air to surface being insulated.

3.08 INSTALLATION OF GLASS-FIBER AND MINERAL WOOL INSULATION

- A. Insulation Installation on Straight Pipes and Tubes:
 - 1. Secure each layer of preformed pipe insulation to pipe with wire or bands, and tighten bands without deforming insulation materials.
 - 2. Where vapor barriers are indicated, seal longitudinal seams, end joints, and protrusions with vapor-barrier mastic and joint sealant.
 - 3. For insulation with jackets on above-ambient surfaces, secure laps with outward-clinched staples at 6 inches o.c.
 - 4. For insulation with jackets on below-ambient surfaces, do not staple longitudinal tabs. Instead, secure tabs with additional adhesive, as recommended by insulation material manufacturer, and seal with vapor-barrier mastic and flashing sealant.
- B. Insulation Installation on Pipe Flanges:
 - 1. Install prefabricated pipe insulation to outer diameter of pipe flange.
 - 2. Make width of insulation section same as overall width of flange and bolts, plus twice the thickness of pipe insulation.
 - 3. Fill voids between inner circumference of flange insulation and outer circumference of adjacent straight pipe segments with glass-fiber or mineral-wool blanket insulation.
 - 4. Install jacket material with manufacturer's recommended adhesive, overlap seams at least 1 inch, and seal joints with flashing sealant.
- C. Insulation Installation on Pipe Fittings and Elbows:
 - 1. Install prefabricated sections of same material as that of straight segments of pipe insulation when available.
 - 2. When preformed insulation elbows and fittings are not available, install mitered sections of pipe insulation, to a thickness equal to adjoining pipe insulation. Secure insulation materials with wire or bands.
- D. Insulation Installation on Valves and Pipe Specialties:
 - 1. Install prefabricated sections of same material as that of straight segments of pipe insulation when available.
 - 2. When prefabricated sections are not available, install fabricated sections of pipe insulation to valve body.
 - 3. Arrange insulation to permit access to packing and to allow valve operation without disturbing insulation.
 - 4. Install insulation to flanges as specified for flange insulation application.

3.09 INSTALLATION OF FIELD-APPLIED JACKETS

- A. Where glass-cloth jackets are indicated, install directly over bare insulation or insulation with factory-applied jackets.
 - 1. Draw jacket smooth and tight to surface with 2-inch overlap at seams and joints.
 - 2. Embed glass cloth between two 0.062-inch- thick coats of lagging adhesive.
 - 3. Completely encapsulate insulation with coating, leaving no exposed insulation.
- B. Where FSK jackets are indicated, install as follows:
 - 1. Draw jacket material smooth and tight.
 - 2. Install lap or joint strips with same material as jacket.
 - 3. Secure jacket to insulation with manufacturer's recommended adhesive.
 - 4. Install jacket with 1-1/2-inch laps at longitudinal seams and 3-inch- wide joint strips at end joints.
 - 5. Seal openings, punctures, and breaks in vapor-retarder jackets and exposed insulation with vapor-barrier mastic.
- C. Where PVC jackets are indicated and for horizontal applications, install with 1-inch overlap at longitudinal seams and end joints. Seal with manufacturer's recommended adhesive.

1. Apply two continuous beads of adhesive to seams and joints, one bead under lap and the finish bead along seam and joint edge.

3.10 FINISHES

- A. Insulation with ASJ, Glass-Cloth, or Other Paintable Jacket Material: Paint jacket with paint system identified below and as specified in Section 099113 "Exterior Painting" and Section 099123 "Interior Painting."
 1. Flat Acrylic Finish: Two finish coats over a primer that is compatible with jacket material and finish coat paint. Add fungicidal agent to render fabric mildew proof.
 - a. Finish Coat Material: Interior, flat, latex-emulsion size.
- B. Flexible Elastomeric Thermal Insulation: After adhesive has fully cured, apply two coats of insulation manufacturer's recommended protective coating.
- C. Color: Final color as selected by Architect. Vary first and second coats to allow visual inspection of the completed Work.
- D. Do not field paint aluminum or stainless steel jackets.

3.11 FIELD QUALITY CONTROL

- A. Owner will engage a qualified testing agency to perform tests and inspections.
- B. Engage a qualified testing agency to perform tests and inspections.
- C. Manufacturer's Field Service: Engage a factory-authorized service representative to test and inspect components, assemblies, and equipment installations, including connections.
- D. Perform tests and inspections with the assistance of a factory-authorized service representative.
- E. Tests and Inspections: Inspect pipe, fittings, strainers, and valves, randomly selected by Architect, by removing field-applied jacket and insulation in layers in reverse order of their installation. Extent of inspection is limited to three locations of straight pipe, three locations of threaded fittings, three locations of welded fittings, two locations of threaded strainers, two locations of welded strainers, three locations of threaded valves, and three locations of flanged valves for each pipe service defined in the "Piping Insulation Schedule, General" Article.
- F. All insulation applications will be considered defective if they do not pass tests and inspections.
- G. Prepare test and inspection reports.

3.12 PIPING INSULATION SCHEDULE, GENERAL

- A. Insulation conductivity and thickness per pipe size comply with schedules in this Section or with requirements of authorities having jurisdiction, whichever is more stringent.
- B. Acceptable preformed pipe and tubular insulation materials and thicknesses are identified for each piping system and pipe size range. If more than one material is listed for a piping system, selection from materials listed is Contractor's option.
- C. Items Not Insulated: Unless otherwise indicated, do not install insulation on the following:
 1. Underground piping.
 2. Chrome-plated pipes and fittings unless there is a potential for personnel injury.

3.13 INDOOR PIPING INSULATION SCHEDULE

- A. Condensate and Equipment Drain Water below 60 Deg F:
 1. All Pipe Sizes: See drawings.
- B. Chilled Water and Brine, 60 Deg F and below:
 1. NPS 8 and Smaller: See drawings.
 2. NPS 8 and larger: See drawings.
- C. Heating-Hot-Water Supply and Return, 200 Deg F and Below:
 1. NPS 1-1/4 and Smaller: See drawings.
 2. NPS 1-1/2 and Larger: See drawings.

3.14 INDOOR, FIELD-APPLIED JACKET SCHEDULE

- A. Install jacket over insulation material. For insulation with factory-applied jacket, install the field-applied jacket over the factory-applied jacket.
- B. If more than one material is listed, selection from materials listed is Contractor's option.
- C. Piping, Concealed: See drawings.
- D. Piping, Exposed: See drawings.

END OF SECTION 23 0719

SECTION 23 2113 - HYDRONIC PIPING

PART 1 GENERAL

1.01 RELATED DOCUMENTS

- A. Drawings and general provisions of the Contract, including General and Supplementary Conditions and Division 01 Specification Sections, apply to this Section.

1.02 SUMMARY

- A. Section includes pipe and fitting materials and joining methods for the following:
 1. Hot-water heating piping.
 2. Makeup-water piping.
 3. Condensate-drain piping.
 4. Safety-valve-inlet and -outlet piping.

1.03 ACTION SUBMITTALS

1.04 INFORMATIONAL SUBMITTALS

- A. Coordination Drawings: Piping layout, drawn to scale, on which the following items are shown and coordinated with each other, using input from installers of the items involved:
 1. Suspended ceiling components.
 2. Other building services.
 3. Structural members.
- B. Qualification Data: For Installer.
- C. Welding certificates.
- D. Field quality-control reports.
- E. Water Analysis: Submit a copy of the water analysis to illustrate water quality available at Project site.

1.05 QUALITY ASSURANCE

- A. Installer Qualifications:
 1. Installers of Pressure-Sealed Joints: Installers shall be certified by pressure-seal joint manufacturer as having been trained and qualified to join piping with pressure-seal pipe couplings and fittings.
 2. Fiberglass Pipe and Fitting Installers: Installers of RTRF and RTRP shall be certified by manufacturer of pipes and fittings as having been trained and qualified to join fiberglass piping with manufacturer-recommended adhesive.
- B. Steel Support Welding: Qualify procedures and personnel according to AWS D1.1/D1.1M, "Structural Welding Code - Steel."
- C. Pipe Welding: Qualify procedures and operators according to ASME Boiler and Pressure Vessel Code: Section IX.
 1. Comply with ASME B31.9, "Building Services Piping," for materials, products, and installation.
 2. Certify that each welder has passed AWS qualification tests for welding processes involved and that certification is current.

PART 2 PRODUCTS

2.01 PERFORMANCE REQUIREMENTS

- A. Hydronic piping components and installation shall be capable of withstanding the following minimum working pressure and temperature unless otherwise indicated:
 1. Hot-Water Heating Piping: 150 psig at 200 deg F.
 2. Makeup-Water Piping: 80 psig at 150 deg F.
 3. Condensate-Drain Piping: 150 deg F.

4. Safety-Valve-Inlet and -Outlet Piping: Equal to the pressure of the piping system to which it is attached.

2.02 COPPER TUBE AND FITTINGS

- A. Drawn-Temper Copper Tubing: ASTM B 88, Type L, ASTM B 88, Type M.
- B. Annealed-Temper Copper Tubing: ASTM B 88, Type K.
- C. DWV Copper Tubing: ASTM B 306, Type DWV.
- D. Grooved, Mechanical-Joint, Wrought-Copper Fittings: ASME B16.22.
 1. Grooved-End Copper Fittings: ASTM B 75, copper tube or ASTM B 584, bronze casting.
 2. Grooved-End-Tube Couplings: Rigid pattern unless otherwise indicated; gasketed fitting. Ductile-iron housing with keys matching pipe and fitting grooves, prelubricated EPDM gasket rated for minimum 230 deg F for use with housing, and steel bolts and nuts.
- E. Copper or Bronze Pressure-Seal Fittings:
 1. Housing: Copper.
 2. O-Rings and Pipe Stops: EPDM.
 3. Tools: Manufacturer's special tools.
 4. Minimum 200-psig working-pressure rating at 250 deg F.
- F. Wrought-Copper Unions: ASME B16.22.

2.03 STEEL PIPE AND FITTINGS

- A. Steel Pipe: ASTM A 53/A 53M, black steel with plain ends; welded and seamless, Grade B, and wall thickness as indicated in "Piping Applications" Article.
- B. Cast-Iron Threaded Fittings: ASME B16.4; Classes 125 and 250 as indicated in "Piping Applications" Article.
- C. Malleable-Iron Threaded Fittings: ASME B16.3, Classes 150 and 300 as indicated in "Piping Applications" Article.
- D. Malleable-Iron Unions: ASME B16.39; Classes 150, 250, and 300 as indicated in "Piping Applications" Article.
- E. Cast-Iron Pipe Flanges and Flanged Fittings: ASME B16.1, Classes 25, 125, and 250; raised ground face, and bolt holes spot faced as indicated in "Piping Applications" Article.
- F. Wrought-Steel Fittings: ASTM A 234/A 234M, wall thickness to match adjoining pipe.
- G. Wrought Cast- and Forged-Steel Flanges and Flanged Fittings: ASME B16.5, including bolts, nuts, and gaskets of the following material group, end connections, and facings:
 1. Material Group: 1.1.
 2. End Connections: Butt welding.
 3. Facings: Raised face.
- H. Grooved Mechanical-Joint Fittings and Couplings:
 1. Joint Fittings: ASTM A 536, Grade 65-45-12 ductile iron; ASTM A 47/A 47M, Grade 32510 malleable iron; ASTM A 53/A 53M, Type F, E, or S, Grade B fabricated steel; or ASTM A 106/A 106M, Grade B steel fittings with grooves or shoulders constructed to accept grooved-end couplings; with nuts, bolts, locking pin, locking toggle, or lugs to secure grooved pipe and fittings.
 2. Couplings: Ductile- or malleable-iron housing and EPDM or nitrile gasket of central cavity pressure-responsive design; with nuts, bolts, locking pin, locking toggle, or lugs to secure grooved pipe and fittings.
- I. Steel Pressure-Seal Fittings:
 1. Housing: Steel.
 2. O-Rings and Pipe Stop: EPDM.
 3. Tools: Manufacturer's special tool.
 4. Minimum 300-psig working-pressure rating at 230 deg F.

- J. Steel Pipe Nipples: ASTM A 733, made of same materials and wall thicknesses as pipe in which they are installed.

2.04 PLASTIC PIPE AND FITTINGS

- A. CPVC Plastic Pipe: ASTM F 441/F 441M, with wall thickness as indicated in "Piping Applications" Article.
 - 1. CPVC Plastic Pipe Fittings: Socket-type pipe fittings, ASTM F 438 for Schedule 40 pipe; ASTM F 439 for Schedule 80 pipe.
- B. PVC Plastic Pipe: ASTM D 1785, with wall thickness as indicated in "Piping Applications" Article.
 - 1. PVC Plastic Pipe Fittings: Socket-type pipe fittings, ASTM D 2466 for Schedule 40 pipe; ASTM D 2467 for Schedule 80 pipe.

2.05 JOINING MATERIALS

- A. Pipe-Flange Gasket Materials: Suitable for chemical and thermal conditions of piping system contents.
 - 1. ASME B16.21, nonmetallic, flat, asbestos free, 1/8-inch maximum thickness unless otherwise indicated.
 - a. Full-Face Type: For flat-face, Class 125, cast-iron and cast-bronze flanges.
 - b. Narrow-Face Type: For raised-face, Class 250, cast-iron and steel flanges.
- B. Flange Bolts and Nuts: ASME B18.2.1, carbon steel, unless otherwise indicated.
- C. Plastic, Pipe-Flange Gasket, Bolts, and Nuts: Type and material recommended by piping system manufacturer unless otherwise indicated.
- D. Solder Filler Metals: ASTM B 32, lead-free alloys. Include water-flushable flux according to ASTM B 813.
- E. Brazing Filler Metals: AWS A5.8/A5.8M, BCuP Series, copper-phosphorus alloys for joining copper with copper; or BAg-1, silver alloy for joining copper with bronze or steel.
- F. Welding Filler Metals: Comply with AWS D10.12M/D10.12 for welding materials appropriate for wall thickness and chemical analysis of steel pipe being welded.
- G. Solvent Cements for Joining Plastic Piping:
 - 1. CPVC Piping: ASTM F 493.
 - a. CPVC solvent cement shall have a VOC content of 490 g/L or less.
 - b. Adhesive primer shall have a VOC content of 550 g/L or less.
 - c. Solvent cement and adhesive primer shall comply with the testing and product requirements of the California Department of Public Health's (formerly, the California Health Services') "Standard Method for the Testing and Evaluation of Volatile Organic Chemical Emissions from Indoor Sources Using Environmental Chambers."
 - 2. PVC Piping: ASTM D 2564. Include primer according to ASTM F 656.
 - a. PVC solvent cement shall have a VOC content of 510 g/L or less.
 - b. Adhesive primer shall have a VOC content of 550 g/L or less.
 - c. Solvent cement and adhesive primer shall comply with the testing and product requirements of the California Department of Public Health's (formerly, the California Health Services') "Standard Method for the Testing and Evaluation of Volatile Organic Chemical Emissions from Indoor Sources Using Environmental Chambers."

2.06 TRANSITION FITTINGS

- A. Plastic-to-Metal Transition Fittings:
 - 1. One-piece fitting with one threaded brass or copper insert and one solvent-cement-joint end of material and wall thickness to match plastic pipe material.
- B. Plastic-to-Metal Transition Unions:
 - 1. Brass or copper end, solvent-cement-joint end of material and wall thickness to match plastic pipe material, rubber gasket, and threaded union.

2.07 DIELECTRIC FITTINGS

- A. General Requirements: Assembly of copper alloy and ferrous materials with separating nonconductive insulating material. Include end connections compatible with pipes to be joined.
 - a. Standard: ASSE 1079.
 - b. Pressure Rating: 150 psig.
 - c. End Connections: Solder-joint copper alloy and threaded ferrous.
- B. Dielectric Flanges:
 - 1. Description:
 - a. Standard: ASSE 1079.
 - b. Factory-fabricated, bolted, companion-flange assembly.
 - c. Pressure Rating: 150 psig.
 - d. End Connections: Solder-joint copper alloy and threaded ferrous; threaded solder-joint copper alloy and threaded ferrous.
- C. Dielectric-Flange Insulating Kits:
 - 1. Description:
 - a. Nonconducting materials for field assembly of companion flanges.
 - b. Pressure Rating: 150 psig.
 - c. Gasket: Neoprene or phenolic.
 - d. Bolt Sleeves: Phenolic or polyethylene.
 - e. Washers: Phenolic with steel backing washers.
- D. Dielectric Nipples:
 - 1. Description:
 - a. Standard: IAPMO PS 66.
 - b. Electroplated steel nipple, complying with ASTM F 1545.
 - c. Pressure Rating: 300 psig at 225 deg F.
 - d. End Connections: Male threaded or grooved.
 - e. Lining: Inert and noncorrosive, propylene.

2.08 BYPASS CHEMICAL FEEDER

- A. Description: Welded steel construction; 125-psig working pressure; 5-gal. capacity; with fill funnel and inlet, outlet, and drain valves.
 - 1. Chemicals: Specially formulated, based on analysis of makeup water, to prevent accumulation of scale and corrosion in piping and connected equipment.

PART 3 EXECUTION

3.01 PIPING APPLICATIONS

- A. Hot-water heating-water piping, aboveground, NPS 2, shall be any of the following:
 - 1. Type L, drawn-temper copper tubing, wrought-copper fittings, and soldered, brazed, or pressure-seal joints.
 - 2. Schedule 40, Grade B, Type 96 steel pipe; Class 150, malleable-iron fittings; cast-iron flanges and flange fittings; and threaded joints.
- B. Hot-water heating-water piping, aboveground, NPS 2-1/2 and larger, shall be any of the following:
 - 1. Type L, drawn-temper copper tubing, wrought-copper fittings, and soldered, or brazed joints.
 - 2. Schedule 40 steel pipe, wrought-steel fittings and wrought-cast or forged-steel flanges and flange fittings, and welded and flanged joints.
 - 3. Schedule 40 steel pipe; grooved, mechanical joint coupling and fittings; and grooved, mechanical joints.
- C. Makeup-water piping installed aboveground shall be either of the following:
 - 1. Type L, drawn-temper copper tubing, wrought-copper fittings, and soldered or brazed

joints.

- D. Condensate-Drain Piping: Type M Type DWV, drawn-temper copper tubing, wrought-copper fittings, and soldered joints or Schedule 40 PVC plastic pipe and fittings and solvent-welded joints.
- E. Condensate-Drain Piping: Schedule 40 PVC plastic pipe and fittings and solvent-welded joints.
- F. Safety-Valve-Inlet and -Outlet Piping for Hot-Water Piping: Same materials and joining methods as for piping specified for the service in which safety valve is installed with metal-to-plastic transition fittings for plastic piping systems according to piping manufacturer's written instructions.

3.02 PIPING INSTALLATIONS

- A. Drawing plans, schematics, and diagrams indicate general location and arrangement of piping systems. Install piping as indicated unless deviations to layout are approved on Coordination Drawings.
- B. Install piping in concealed locations unless otherwise indicated and except in equipment rooms and service areas.
- C. Install piping indicated to be exposed and piping in equipment rooms and service areas at right angles or parallel to building walls. Diagonal runs are prohibited unless specifically indicated otherwise.
- D. Install piping above accessible ceilings to allow sufficient space for ceiling panel removal.
- E. Install piping to permit valve servicing.
- F. Install piping at indicated slopes.
- G. Install piping free of sags and bends.
- H. Install fittings for changes in direction and branch connections.
- I. Install piping to allow application of insulation.
- J. Select system components with pressure rating equal to or greater than system operating pressure.
- K. Install groups of pipes parallel to each other, spaced to permit applying insulation and servicing of valves.
- L. Install drains, consisting of a tee fitting, NPS 3/4 ball valve, and short NPS 3/4 threaded nipple with cap, at low points in piping system mains for proper system drainage.
- M. Install piping at a uniform grade of 0.2 percent upward in direction of flow.
- N. Reduce pipe sizes using eccentric reducer fitting installed with level side up.
- O. Install branch connections to mains using mechanically formed tee fittings in main pipe, with the branch connected to the bottom of the main pipe. For up-feed risers, connect the branch to the top of the main pipe.
- P. Install unions in piping, NPS 2 and smaller, adjacent to valves, at final connections of equipment, and elsewhere as indicated.
- Q. Install flanges in piping, NPS 2-1/2 and larger, at final connections of equipment and elsewhere as indicated.
- R. Install shutoff valve immediately upstream of each dielectric fitting.
- S. Install sleeves for piping penetrations of walls, ceilings, and floors.
- T. Install sleeve seals for piping penetrations of concrete walls and slabs.
- U. Install escutcheons for piping penetrations of walls, ceilings, and floors.

3.03 DIELECTRIC FITTING INSTALLATION

- A. Install dielectric fittings in piping at connections of dissimilar metal piping and tubing.

- B. Dielectric Fittings for NPS 2 and Smaller: Use dielectric nipples or unions.
- C. Dielectric Fittings for NPS 2-1/2 to NPS 4: Use dielectric flanges, flange kits, or nipples.
- D. Dielectric Fittings for NPS 5 and Larger: Use dielectric flange kits.

3.04 HANGERS AND SUPPORTS

- A. Comply with requirements in Section 230529 "Hangers and Supports for HVAC Piping and Equipment" for hanger, support, and anchor devices. Comply with the following requirements for maximum spacing of supports.
- B. Install the following pipe attachments:
 - 1. Adjustable steel clevis hangers for individual horizontal piping less than 20 feet long.
 - 2. Adjustable roller hangers and spring hangers for individual horizontal piping 20 feet or longer.
 - 3. Pipe Roller: MSS SP-58, Type 44 for multiple horizontal piping 20 feet or longer, supported on a trapeze.
 - 4. Spring hangers to support vertical runs.
 - 5. Provide copper-clad hangers and supports for hangers and supports in direct contact with copper pipe.
 - 6. On plastic pipe, install pads or cushions on bearing surfaces to prevent hanger from scratching pipe.
- C. Install hangers for steel piping with the following maximum spacing and minimum rod sizes:
 - 1. NPS 3/4: Maximum span, 7 feet.
 - 2. NPS 1: Maximum span, 7 feet.
 - 3. NPS 1-1/2: Maximum span, 9 feet.
 - 4. NPS 2: Maximum span, 10 feet.
 - 5. NPS 2-1/2: Maximum span, 11 feet.
 - 6. NPS 3 and Larger: Maximum span, 12 feet.
- D. Install hangers for drawn-temper copper piping with the following maximum spacing and minimum rod sizes:
 - 1. NPS 3/4: Maximum span, 5 feet; minimum rod size, 1/4 inch.
 - 2. NPS 1: Maximum span, 6 feet; minimum rod size, 1/4 inch.
 - 3. NPS 1-1/4 Maximum span, 7 feet; minimum rod size, 3/8 inch.
 - 4. NPS 1-1/2: Maximum span, 8 feet; minimum rod size, 3/8 inch.
 - 5. NPS 2: Maximum span, 8 feet; minimum rod size, 3/8 inch.
 - 6. NPS 2-1/2: Maximum span, 9 feet; minimum rod size, 3/8 inch.
 - 7. NPS 3 and Larger: Maximum span, 10 feet; minimum rod size, 3/8 inch.
- E. Plastic Piping Hanger Spacing: Space hangers according to pipe manufacturer's written instructions for service conditions. Avoid point loading. Space and install hangers with the fewest practical rigid anchor points.
- F. Fiberglass Piping Hanger Spacing: Space hangers according to pipe manufacturer's written instructions for service conditions. Avoid point loading. Space and install hangers with the fewest practical rigid anchor points.
- G. Support vertical runs at roof, at each floor, and at 10-foot intervals between floors.

3.05 PIPE JOINT CONSTRUCTION

- A. Ream ends of pipes and tubes and remove burrs. Bevel plain ends of steel pipe.
- B. Remove scale, slag, dirt, and debris from inside and outside of pipe and fittings before assembly.
- C. Soldered Joints: Apply ASTM B 813, water-flushable flux, unless otherwise indicated, to tube end. Construct joints according to ASTM B 828 or CDA's "Copper Tube Handbook," using lead-free solder alloy complying with ASTM B 32.

- D. Brazed Joints: Construct joints according to AWS's "Brazing Handbook," "Pipe and Tube" Chapter, using copper-phosphorus brazing filler metal complying with AWS A5.8/A5.8M.
- E. Threaded Joints: Thread pipe with tapered pipe threads according to ASME B1.20.1. Cut threads full and clean using sharp dies. Ream threaded pipe ends to remove burrs and restore full ID. Join pipe fittings and valves as follows:
 - 1. Apply appropriate tape or thread compound to external pipe threads unless dry seal threading is specified.
 - 2. Damaged Threads: Do not use pipe or pipe fittings with threads that are corroded or damaged. Do not use pipe sections that have cracked or open welds.
- F. Welded Joints: Construct joints according to AWS D10.12M/D10.12, using qualified processes and welding operators according to "Quality Assurance" Article.
- G. Flanged Joints: Select appropriate gasket material, size, type, and thickness for service application. Install gasket concentrically positioned. Use suitable lubricants on bolt threads.
- H. Plastic Piping Solvent-Cemented Joints: Clean and dry joining surfaces. Join pipe and fittings according to the following:
 - 1. Comply with ASTM F 402 for safe-handling practice of cleaners, primers, and solvent cements.
 - 2. CPVC Piping: Join according to ASTM D 2846/D 2846M Appendix.
 - 3. PVC Pressure Piping: Join ASTM D 1785 schedule number, PVC pipe and PVC socket fittings according to ASTM D 2672. Join other-than-schedule number PVC pipe and socket fittings according to ASTM D 2855.
 - 4. PVC Nonpressure Piping: Join according to ASTM D 2855.
- I. Fiberglass Bonded Joints: Prepare pipe ends and fittings, apply adhesive, and join according to pipe manufacturer's written instructions.
- J. Grooved Joints: Assemble joints with coupling and gasket, lubricant, and bolts. Cut or roll grooves in ends of pipe based on pipe and coupling manufacturer's written instructions for pipe wall thickness. Use grooved-end fittings and rigid, grooved-end-pipe couplings.
- K. Mechanically Formed, Copper-Tube-Outlet Joints: Use manufacturer-recommended tool and procedure, and brazed joints.
- L. Pressure-Sealed Joints: Use manufacturer-recommended tool and procedure. Leave insertion marks on pipe after assembly.

3.06 TERMINAL EQUIPMENT CONNECTIONS

- A. Sizes for supply and return piping connections shall be the same as or larger than equipment connections.
- B. Install control valves in accessible locations close to connected equipment.
- C. Install bypass piping with globe valve around control valve. If parallel control valves are installed, only one bypass is required.
- D. Install ports for pressure gages and thermometers at coil inlet and outlet connections.

3.07 CHEMICAL TREATMENT

- A. Perform an analysis of makeup water to determine type and quantities of chemical treatment needed to keep system free of scale, corrosion, and fouling, and to sustain the following water characteristics:
 - 1. pH: 9.0 to 10.5.
 - 2. "P" Alkalinity: 100 to 500 ppm.
 - 3. Boron: 100 to 200 ppm.
 - 4. Chemical Oxygen Demand: Maximum of 100 ppm. Revise this value if closed system contains glycol.
 - 5. Corrosion Inhibitor:
 - a. Sodium Nitrate: 1000 to 1500 ppm.

- b. Molybdate: 200 to 300 ppm.
- c. Chromate: 200 to 300 ppm.
- d. Sodium Nitrate Plus Molybdate: 100 to 200 ppm each.
- e. Chromate Plus Molybdate: 50 to 100 ppm each.
- 6. Soluble Copper: Maximum of 0.20 ppm.
- 7. Tolyriazole Copper and Yellow Metal Corrosion Inhibitor: Minimum of 10 ppm.
- 8. Total Suspended Solids: Maximum of 10 ppm.
- 9. Ammonia: Maximum of 20 ppm.
- 10. Free Caustic Alkalinity: Maximum of 20 ppm.
- 11. Microbiological Limits:
 - a. Total Aerobic Plate Count: Maximum of 1000 organisms/mL.
 - b. Total Anaerobic Plate Count: Maximum of 100 organisms/mL.
 - c. Nitrate Reducers: 100 organisms/mL.
 - d. Sulfate Reducers: Maximum of zero organisms/mL.
 - e. Iron Bacteria: Maximum of zero organisms/mL.
- B. Install bypass chemical feeders in each hydronic system where indicated.
 - 1. Install in upright position with top of funnel not more than 48 inches above the floor.
 - 2. Install feeder in minimum NPS 3/4 bypass line, from main with full-size, full-port, ball valve in the main between bypass connections.
 - 3. Install NPS 3/4 pipe from chemical feeder drain to nearest equipment drain and include a full-size, full-port, ball valve.
- C. Fill system with fresh water and add liquid alkaline compound with emulsifying agents and detergents to remove grease and petroleum products from piping. Circulate solution for a minimum of 24 hours, drain, clean strainer screens, and refill with fresh water.
- D. Add initial chemical treatment and maintain water quality in ranges noted above for the first year of operation.
- E. Fill systems that have antifreeze or glycol solutions with the following concentrations:
 - 1. Hot-Water Heating Piping: Minimum of 30 percent propylene glycol.

3.08 FIELD QUALITY CONTROL

- A. Prepare hydronic piping according to ASME B31.9 and as follows:
 - 1. Leave joints, including welds, uninsulated and exposed for examination during test.
 - 2. Provide temporary restraints for expansion joints that cannot sustain reactions due to test pressure. If temporary restraints are impractical, isolate expansion joints from testing.
 - 3. Flush hydronic piping systems with clean water; then remove and clean or replace strainer screens.
 - 4. Isolate equipment from piping. If a valve is used to isolate equipment, its closure shall be capable of sealing against test pressure without damage to valve. Install blinds in flanged joints to isolate equipment.
 - 5. Install safety valve, set at a pressure no more than one-third higher than test pressure, to protect against damage by expanding liquid or other source of overpressure during test.
- B. Perform the following tests on hydronic piping:
 - 1. Use ambient temperature water as a testing medium unless there is risk of damage due to freezing. Another liquid that is safe for workers and compatible with piping may be used.
 - 2. While filling system, use vents installed at high points of system to release air. Use drains installed at low points for complete draining of test liquid.
 - 3. Isolate expansion tanks and determine that hydronic system is full of water.
 - 4. Subject piping system to hydrostatic test pressure that is not less than 1.5 times the system's working pressure. Test pressure shall not exceed maximum pressure for any vessel, pump, valve, or other component in system under test. Verify that stress due to pressure at bottom of vertical runs does not exceed 90 percent of specified minimum yield strength or 1.7 times the "SE" value in Appendix A in ASME B31.9, "Building Services Piping."

5. After hydrostatic test pressure has been applied for at least 10 minutes, examine piping, joints, and connections for leakage. Eliminate leaks by tightening, repairing, or replacing components, and repeat hydrostatic test until there are no leaks.
 6. Prepare written report of testing.
- C. Perform the following before operating the system:
1. Open manual valves fully.
 2. Inspect pumps for proper rotation.
 3. Set makeup pressure-reducing valves for required system pressure.
 4. Inspect air vents at high points of system and determine if all are installed and operating freely (automatic type), or bleed air completely (manual type).
 5. Set temperature controls so all coils are calling for full flow.
 6. Inspect and set operating temperatures of hydronic equipment, such as boilers, chillers, cooling towers, to specified values.
 7. Verify lubrication of motors and bearings.

END OF SECTION 23 2113

This page intentionally left blank

SECTION 23 3113 - METAL DUCTS

PART 1 - GENERAL

1.01 RELATED DOCUMENTS

- A. Drawings and general provisions of the Contract, including General and Supplementary Conditions and Division 01 Specification Sections, apply to this Section.

1.02 SUMMARY

- A. Section Includes:
 1. Single-wall rectangular ducts and fittings.
 2. Single-wall round ducts and fittings.
 3. Sheet metal materials.
 4. Duct liner.
 5. Hangers and supports.

1.03 PERFORMANCE REQUIREMENTS

- A. Delegated Duct Design: Duct construction, including sheet metal thicknesses, seam and joint construction, reinforcements, and hangers and supports, shall comply with SMACNA's "HVAC Duct Construction Standards - Metal and Flexible" and performance requirements and design criteria indicated in "Duct Schedule" Article.
- B. Structural Performance: Duct hangers and supports shall withstand the effects of gravity loads and stresses within limits and under conditions described in SMACNA's "HVAC Duct Construction Standards - Metal and Flexible".
- C. Airstream Surfaces: Surfaces in contact with the airstream shall comply with requirements in ASHRAE 62.1.

1.04 ACTION SUBMITTALS

- A. Product Data: For each type of the following products:
 1. Liners and adhesives.
 2. Sealants and gaskets.
- B. Shop Drawings:
 1. Fabrication, assembly, and installation, including plans, elevations, sections, components, and attachments to other work.
 2. Factory- and shop-fabricated ducts and fittings.
 3. Duct layout indicating sizes, configuration, liner material, and static-pressure classes.
 4. Elevation of top of ducts.
 5. Dimensions of main duct runs from building grid lines.
 6. Fittings.
 7. Reinforcement and spacing.
 8. Seam and joint construction.
 9. Penetrations through fire-rated and other partitions.
 10. Equipment installation based on equipment being used on Project.
 11. Locations for duct accessories, including dampers, turning vanes, and access doors and panels.
 12. Hangers and supports, including methods for duct and building attachment and vibration isolation.

- C. Delegated-Design Submittal:
 - 1. Sheet metal thicknesses.
 - 2. Joint and seam construction and sealing.
 - 3. Reinforcement details and spacing.
 - 4. Materials, fabrication, assembly, and spacing of hangers and supports.

1.05 INFORMATIONAL SUBMITTALS

- A. Coordination Drawings: Plans, drawn to scale, on which the following items are shown and coordinated with each other, using input from installers of the items involved:
 - 1. Duct installation in congested spaces, indicating coordination with general construction, building components, and other building services. Indicate proposed changes to duct layout.
 - 2. Suspended ceiling components.
 - 3. Structural members to which duct will be attached.
 - 4. Size and location of initial access modules for acoustical tile.
 - 5. Penetrations of smoke barriers and fire-rated construction.
 - 6. Items penetrating finished ceiling including the following:
 - a. Lighting fixtures.
 - b. Air outlets and inlets.
 - c. Speakers.
 - d. Sprinklers.
 - e. Access panels.
 - f. Perimeter moldings.
- B. Field quality-control reports.

PART 2 - PRODUCTS

2.01 SINGLE-WALL RECTANGULAR DUCTS AND FITTINGS

- A. General Fabrication Requirements: Comply with SMACNA's "HVAC Duct Construction Standards - Metal and Flexible" based on indicated static-pressure class unless otherwise indicated.
- B. Transverse Joints: Select joint types and fabricate according to SMACNA's "HVAC Duct Construction Standards - Metal and Flexible," Figure 2-1, "Rectangular Duct/Transverse Joints," for static-pressure class, applicable sealing requirements, materials involved, duct-support intervals, and other provisions in SMACNA's "HVAC Duct Construction Standards - Metal and Flexible."
- C. Longitudinal Seams: Select seam types and fabricate according to SMACNA's "HVAC Duct Construction Standards - Metal and Flexible," Figure 2-2, "Rectangular Duct/Longitudinal Seams," for static-pressure class, applicable sealing requirements, materials involved, duct-support intervals, and other provisions in SMACNA's "HVAC Duct Construction Standards - Metal and Flexible."
- D. Elbows, Transitions, Offsets, Branch Connections, and Other Duct Construction: Select types and fabricate according to SMACNA's "HVAC Duct Construction Standards - Metal and Flexible," Chapter 4, "Fittings and Other Construction," for static-pressure class, applicable sealing requirements, materials involved, duct-support intervals, and other provisions in SMACNA's "HVAC Duct Construction Standards - Metal and Flexible."

2.02 SINGLE-WALL ROUND DUCTS AND FITTINGS

- A. General Fabrication Requirements: Comply with SMACNA's "HVAC Duct Construction Standards - Metal and Flexible," Chapter 3, "Round, Oval, and Flexible Duct," based on indicated static-pressure class unless otherwise indicated.
- B. Transverse Joints: Select joint types and fabricate according to SMACNA's "HVAC Duct Construction Standards - Metal and Flexible," Figure 3-1, "Round Duct Transverse Joints," for static-pressure class, applicable sealing requirements, materials involved, duct-support intervals, and other provisions in SMACNA's "HVAC Duct Construction Standards - Metal and Flexible."
- C. Longitudinal Seams: Select seam types and fabricate according to SMACNA's "HVAC Duct Construction Standards - Metal and Flexible," Figure 3-2, "Round Duct Longitudinal Seams," for static-pressure class, applicable sealing requirements, materials involved, duct-support intervals, and other provisions in SMACNA's "HVAC Duct Construction Standards - Metal and Flexible."
- D. Tees and Laterals: Select types and fabricate according to SMACNA's "HVAC Duct Construction Standards - Metal and Flexible," Figure 3-5, "90 Degree Tees and Laterals," and Figure 3-6, "Conical Tees," for static-pressure class, applicable sealing requirements, materials involved, duct-support intervals, and other provisions in SMACNA's "HVAC Duct Construction Standards - Metal and Flexible."

2.03 SHEET METAL MATERIALS

- A. General Material Requirements: Comply with SMACNA's "HVAC Duct Construction Standards - Metal and Flexible" for acceptable materials, material thicknesses, and duct construction methods unless otherwise indicated. Sheet metal materials shall be free of pitting, seam marks, roller marks, stains, discolorations, and other imperfections.
- B. Galvanized Sheet Steel: Comply with ASTM A 653/A 653M.
 - 1. Galvanized Coating Designation: G60.
 - 2. Finishes for Surfaces Exposed to View: Mill phosphatized.

2.04 DUCT LINER

- A. Fibrous-Glass Duct Liner: Comply with ASTM C 1071, NFPA 90A, or NFPA 90B; and with NAIMA AH124, "Fibrous Glass Duct Liner Standard."
 - 1. Maximum Thermal Conductivity: Type I, Flexible: 0.27 Btu x in./h x sq. ft. x deg F at 75 deg F mean temperature.
- B. Flexible Elastomeric Duct Liner: Preformed, cellular, closed-cell, sheet materials complying with ASTM C 534, Type II, Grade 1; and with NFPA 90A or NFPA 90B.
- C. Insulation Pins and Washers:
 - 1. Cupped-Head, Capacitor-Discharge-Weld Pins: Copper- or zinc-coated steel pin, fully annealed for capacitor-discharge welding, 0.106-inch diameter shank, length to suit depth of insulation indicated with integral 1-1/2-inch galvanized carbon-steel washer.
 - 2. Insulation-Retaining Washers: Self-locking washers formed from 0.016-inch thick galvanized steel; with beveled edge sized as required to hold insulation securely in place but not less than 1-1/2 inches in diameter.
- D. Shop Application of Duct Liner: Comply with SMACNA's "HVAC Duct Construction Standards - Metal and Flexible," Figure 7-11, "Flexible Duct Liner Installation."

1. Adhere a single layer of indicated thickness of duct liner with at least 90 percent adhesive coverage at liner contact surface area. Attaining indicated thickness with multiple layers of duct liner is prohibited.
2. Apply adhesive to transverse edges of liner facing upstream that do not receive metal nosing.
3. Butt transverse joints without gaps, and coat joint with adhesive.
4. Fold and compress liner in corners of rectangular ducts or cut and fit to ensure butted-edge overlapping.
5. Do not apply liner in rectangular ducts with longitudinal joints, except at corners of ducts, unless duct size and dimensions of standard liner make longitudinal joints necessary.
6. Apply adhesive coating on longitudinal seams in ducts with air velocity of 2500 fpm.
7. Secure liner with mechanical fasteners 4 inches from corners and at intervals not exceeding 12 inches transversely; at 3 inches from transverse joints and at intervals not exceeding 18 inches longitudinally.
8. Secure transversely oriented liner edges facing the airstream with metal nosings that have either channel or "Z" profiles or are integrally formed from duct wall. Fabricate edge facings at the following locations:
 - a. Fan discharges.
 - b. Intervals of lined duct preceding unlined duct.
 - c. Upstream edges of transverse joints in ducts where air velocities are higher than 2500 fpm or where indicated.
9. Secure insulation between perforated sheet metal inner duct of same thickness as specified for outer shell. Use mechanical fasteners that maintain inner duct at uniform distance from outer shell without compressing insulation.
 - a. Sheet Metal Inner Duct Perforations: 3/32-inch diameter, with an overall open area of 23 percent.
10. Terminate inner ducts with buildouts attached to fire-damper sleeves, dampers, turning vane assemblies, or other devices. Fabricated buildouts (metal hat sections) or other buildout means are optional; when used, secure buildouts to duct walls with bolts, screws, rivets, or welds.

2.05 HANGERS AND SUPPORTS

- A. Hanger Rods for Noncorrosive Environments: Cadmium-plated steel rods and nuts.
- B. Strap and Rod Sizes: Comply with SMACNA's "HVAC Duct Construction Standards - Metal and Flexible," Table 5-1, "Rectangular Duct Hangers Minimum Size," and Table 5-2, "Minimum Hanger Sizes for Round Duct."
- C. Steel Cables for Galvanized-Steel Ducts: Galvanized steel complying with ASTM A 603.
- D. Steel Cable End Connections: Cadmium-plated steel assemblies with brackets, swivel, and bolts designed for duct hanger service; with an automatic-locking and clamping device.
- E. Duct Attachments: Sheet metal screws, blind rivets, or self-tapping metal screws; compatible with duct materials.
- F. Trapeze and Riser Supports:
 1. Supports for Galvanized-Steel Ducts: Galvanized-steel shapes and plates.

PART 3 - EXECUTION

3.01 DUCT INSTALLATION

- A. Drawing plans, schematics, and diagrams indicate general location and arrangement of duct system. Indicated duct locations, configurations, and arrangements were used to size ducts and calculate friction loss for air-handling equipment sizing and for other design considerations. Install duct systems as indicated unless deviations to layout are approved on Shop Drawings and Coordination Drawings.
- B. Install ducts according to SMACNA's "HVAC Duct Construction Standards - Metal and Flexible" unless otherwise indicated.
- C. Install round ducts in maximum practical lengths.
- D. Install ducts with fewest possible joints.
- E. Install factory- or shop-fabricated fittings for changes in direction, size, and shape and for branch connections.
- F. Unless otherwise indicated, install ducts vertically and horizontally, and parallel and perpendicular to building lines.
- G. Install ducts close to walls, overhead construction, columns, and other structural and permanent enclosure elements of building.
- H. Install ducts with a clearance of 1 inch, plus allowance for insulation thickness.
- I. Route ducts to avoid passing through transformer vaults and electrical equipment rooms and enclosures.
- J. Where ducts pass through non-fire-rated interior partitions and exterior walls and are exposed to view, cover the opening between the partition and duct or duct insulation with sheet metal flanges of same metal thickness as the duct. Overlap openings on four sides by at least 1-1/2 inches.
- K. Where ducts pass through fire-rated interior partitions and exterior walls, install fire dampers.

3.02 DUCT SEALING

- A. Seal ducts for duct static-pressure, seal classes, and leakage classes specified in "Duct Schedule" Article according to SMACNA's "HVAC Duct Construction Standards - Metal and Flexible."
- B. Seal ducts to the following seal classes according to SMACNA's "HVAC Duct Construction Standards - Metal and Flexible":
 - 1. Comply with SMACNA's "HVAC Duct Construction Standards - Metal and Flexible."
 - 2. Outdoor, Supply-Air Ducts: Seal Class A.
 - 3. Outdoor, Exhaust Ducts: Seal Class C.
 - 4. Outdoor, Return-Air Ducts: Seal Class C.
 - 5. Unconditioned Space, Supply-Air Ducts in Pressure Classes 2-Inch wg and Lower: Seal Class B.
 - 6. Unconditioned Space, Supply-Air Ducts in Pressure Classes Higher Than 2-Inch wg: Seal Class A.
 - 7. Unconditioned Space, Exhaust Ducts: Seal Class C.

8. Unconditioned Space, Return-Air Ducts: Seal Class B.
9. Conditioned Space, Supply-Air Ducts in Pressure Classes 2-Inch wg and Lower: Seal Class C.
10. Conditioned Space, Supply-Air Ducts in Pressure Classes Higher Than 2-Inch wg: Seal Class B.
11. Conditioned Space, Exhaust Ducts: Seal Class B.
12. Conditioned Space, Return-Air Ducts: Seal Class C.

3.03 HANGER AND SUPPORT INSTALLATION

- A. Comply with SMACNA's "HVAC Duct Construction Standards - Metal and Flexible," Chapter 5, "Hangers and Supports."
- B. Building Attachments: Concrete inserts, powder-actuated fasteners, or structural-steel fasteners appropriate for construction materials to which hangers are being attached.
 1. Where practical, install concrete inserts before placing concrete.
 2. Install powder-actuated concrete fasteners after concrete is placed and completely cured.
 3. Use powder-actuated concrete fasteners for standard-weight aggregate concretes or for slabs more than 4 inches thick.
 4. Do not use powder-actuated concrete fasteners for lightweight-aggregate concretes or for slabs less than 4 inches thick.
- C. Hanger Spacing: Comply with SMACNA's "HVAC Duct Construction Standards - Metal and Flexible," Table 5-1, "Rectangular Duct Hangers Minimum Size," and Table 5-2, "Minimum Hanger Sizes for Round Duct," for maximum hanger spacing; install hangers and supports within 24 inches of each elbow and within 48 inches of each branch intersection.
- D. Hangers Exposed to View: Threaded rod and angle or channel supports.
- E. Support vertical ducts with steel angles or channel secured to the sides of the duct with welds, bolts, sheet metal screws, or blind rivets; support at each floor and at a maximum intervals of 16 feet.
- F. Install upper attachments to structures. Select and size upper attachments with pull-out, tension, and shear capacities appropriate for supported loads and building materials where used.

3.04 CONNECTIONS

- A. Make connections to equipment with flexible connectors.
- B. Comply with SMACNA's "HVAC Duct Construction Standards - Metal and Flexible" for branch, outlet and inlet, and terminal unit connections.

3.05 PAINTING

- A. Paint interior of metal ducts that are visible through registers and grilles and that do not have duct liner. Apply one coat of flat, black, latex paint over a compatible galvanized-steel primer. Paint materials and application requirements are specified in Section 099113 "Exterior Painting" and Section 099123 "Interior Painting."

3.06 FIELD QUALITY CONTROL

- A. Perform tests and inspections.

- B. Duct System Cleanliness Tests:
 1. Visually inspect duct system to ensure that no visible contaminants are present.
 2. Test sections of metal duct system, chosen randomly by Owner, for cleanliness according to "Vacuum Test" in NADCA ACR, "Assessment, Cleaning and Restoration of HVAC Systems."
 - a. Acceptable Cleanliness Level: Net weight of debris collected on the filter media shall not exceed 0.75 mg/100 sq. cm.
- C. Duct system will be considered defective if it does not pass tests and inspections.
- D. Prepare test and inspection reports.

3.07 DUCT CLEANING

- A. Clean new and existing duct system(s) before testing, adjusting, and balancing.
- B. Use service openings for entry and inspection.
 1. Create new openings and install access panels appropriate for duct static-pressure class if required for cleaning access. Provide insulated panels for insulated or lined duct. Patch insulation and liner as recommended by duct liner manufacturer.
 2. Disconnect and reconnect flexible ducts as needed for cleaning and inspection.
 3. Remove and reinstall ceiling to gain access during the cleaning process.
- C. Particulate Collection and Odor Control:
 1. When venting vacuuming system inside the building, use HEPA filtration with 99.97 percent collection efficiency for 0.3-micron-size (or larger) particles.
 2. When venting vacuuming system to outdoors, use filter to collect debris removed from HVAC system, and locate exhaust downwind and away from air intakes and other points of entry into building.
- D. Clean the following components by removing surface contaminants and deposits:
 1. Air outlets and inlets (registers, grilles, and diffusers).
 2. Supply, return, and exhaust fans including fan housings, plenums (except ceiling supply and return plenums), scrolls, blades or vanes, shafts, baffles, dampers, and drive assemblies.
 3. Air-handling unit internal surfaces and components including mixing box, coil section, air wash systems, spray eliminators, condensate drain pans, humidifiers and dehumidifiers, filters and filter sections, and condensate collectors and drains.
 4. Coils and related components.
 5. Return-air ducts, dampers, actuators, and turning vanes except in ceiling plenums and mechanical equipment rooms.
 6. Supply-air ducts, dampers, actuators, and turning vanes.
 7. Dedicated exhaust and ventilation components and makeup air systems.
- E. Mechanical Cleaning Methodology:
 1. Clean metal duct systems using mechanical cleaning methods that extract contaminants from within duct systems and remove contaminants from building.
 2. Use vacuum-collection devices that are operated continuously during cleaning. Connect vacuum device to downstream end of duct sections so areas being cleaned are under negative pressure.
 3. Use mechanical agitation to dislodge debris adhered to interior duct surfaces without damaging integrity of metal ducts, duct liner, or duct accessories.
 4. Clean fibrous-glass duct liner with HEPA vacuuming equipment; do not permit duct liner to get wet. Replace fibrous-glass duct liner that is damaged, deteriorated, or delaminated or that has friable material, mold, or fungus growth.

5. Clean coils and coil drain pans according to NADCA 1992. Keep drain pan operational. Rinse coils with clean water to remove latent residues and cleaning materials; comb and straighten fins.
6. Provide drainage and cleanup for wash-down procedures.
7. Antimicrobial Agents and Coatings: Apply EPA-registered antimicrobial agents if fungus is present. Apply antimicrobial agents according to manufacturer's written instructions after removal of surface deposits and debris.

3.08 START UP

- A. Air Balance: Comply with requirements in Section 230593 "Testing, Adjusting, and Balancing for HVAC."

3.09 DUCT SCHEDULE

- A. Duct materials and liners: See Drawings.

B. Elbow Configuration:

1. Rectangular Duct: Comply with SMACNA's "HVAC Duct Construction Standards - Metal and Flexible," Figure 4-2, "Rectangular Elbows."
 - a. Velocity 1000 fpm or Lower:
 - 1) Radius Type RE 1 with minimum 0.5 radius-to-diameter ratio.
 - 2) Mitered Type RE 4 without vanes.
 - b. Velocity 1000 to 1500 fpm:
 - 1) Radius Type RE 1 with minimum 1.0 radius-to-diameter ratio.
 - 2) Radius Type RE 3 with minimum 0.5 radius-to-diameter ratio and two vanes.
 - 3) Mitered Type RE 2 with vanes complying with SMACNA's "HVAC Duct Construction Standards - Metal and Flexible," Figure 4-3, "Vanes and Vane Runners," and Figure 4-4, "Vane Support in Elbows."
 - c. Velocity 1500 fpm:
 - 1) Radius Type RE 1 with minimum 1.5 radius-to-diameter ratio.
 - 2) Radius Type RE 3 with minimum 1.0 radius-to-diameter ratio and two vanes.
 - 3) Mitered Type RE 2 with vanes complying with SMACNA's "HVAC Duct Construction Standards - Metal and Flexible," Figure 4-3, "Vanes and Vane Runners," and Figure 4-4, "Vane Support in Elbows."
2. Round Duct: Comply with SMACNA's "HVAC Duct Construction Standards - Metal and Flexible," Figure 3-4, "Round Duct Elbows."
 - a. Minimum Radius-to-Diameter Ratio and Elbow Segments: Comply with SMACNA's "HVAC Duct Construction Standards - Metal and Flexible," Table 3-1, "Mitered Elbows." Elbows with less than 90-degree change of direction have proportionately fewer segments.
 - 1) Velocity 1000 fpm or Lower: 0.5 radius-to-diameter ratio and three segments for 90-degree elbow.
 - 2) Velocity 1000 to 1500 fpm: 1.0 radius-to-diameter ratio and four segments for 90-degree elbow.
 - 3) Velocity 1500 fpm or Higher: 1.5 radius-to-diameter ratio and five segments for 90-degree elbow.

C. Branch Configuration:

1. Rectangular Duct: Comply with SMACNA's "HVAC Duct Construction Standards - Metal and Flexible," Figure 4-6, "Branch Connection."
 - a. Rectangular Main to Rectangular Branch: 45-degree entry.
 - b. Rectangular Main to Round Branch: Spin in.

2. Round: Comply with SMACNA's "HVAC Duct Construction Standards - Metal and Flexible," Figure 3-5, "90 Degree Tees and Laterals," and Figure 3-6, "Conical Tees." Saddle taps are permitted in existing duct.
 - a. Velocity 1000 fpm or Lower: 90-degree tap.
 - b. Velocity 1000 to 1500 fpm: Conical tap.
 - c. Velocity 1500 fpm or Higher: 45-degree lateral.

END OF SECTION 233113

SECTION 23 3300 - AIR DUCT ACCESSORIES

PART 1 - GENERAL

1.01 SUMMARY

- A. Section Includes:
 - 1. Manual volume dampers.
 - 2. Flexible connectors.

1.02 ACTION SUBMITTALS

- A. Product Data: For each type of product.

PART 2 - PRODUCTS

2.01 ASSEMBLY DESCRIPTION

- A. Comply with NFPA 90A, "Installation of Air Conditioning and Ventilating Systems," and with NFPA 90B, "Installation of Warm Air Heating and Air Conditioning Systems."
- B. Comply with SMACNA's "HVAC Duct Construction Standards - Metal and Flexible" for acceptable materials, material thicknesses, and duct construction methods unless otherwise indicated. Sheet metal materials shall be free of pitting, seam marks, roller marks, stains, discolorations, and other imperfections.

2.02 MANUAL VOLUME DAMPERS

- A. Standard, Steel, Manual Volume Dampers:
 - 1. Standard leakage rating.
 - 2. Suitable for horizontal or vertical applications.
 - 3. Frames:
 - a. Frame: Hat-shaped, 0.094-inch-thick, galvanized sheet steel.
 - b. Mitered and welded corners.
 - c. Flanges for attaching to walls and flangeless frames for installing in ducts.
 - 4. Blades:
 - a. Multiple or single blade.
 - b. Parallel- or opposed-blade design.
 - c. Stiffen damper blades for stability.
 - d. Galvanized-steel, 0.064 inch thick.
 - 5. Blade Axles: Galvanized steel.

2.03 FLEXIBLE CONNECTORS

- A. Materials: Flame-retardant or noncombustible fabrics.
- B. Coatings and Adhesives: Comply with UL 181, Class 1.
- C. Metal-Edged Connectors: Factory fabricated with a fabric strip 3-1/2 inches wide attached to two strips of 2-3/4-inch-wide, 0.028-inch-thick, galvanized sheet steel or 0.032-inch-thick aluminum sheets. Provide metal compatible with connected ducts.
- D. Indoor System, Flexible Connector Fabric: Glass fabric double coated with neoprene.
 - 1. Minimum Weight: 26 oz./sq. yd.
 - 2. Tensile Strength: 480 lbf/inch in the warp and 360 lbf/inch in the filling.
 - 3. Service Temperature: Minus 40 to plus 200 deg F.
- E. Outdoor System, Flexible Connector Fabric: Glass fabric double coated with weatherproof, synthetic rubber resistant to UV rays and ozone.
 - 1. Minimum Weight: 24 oz./sq. yd.

2. Tensile Strength: 530 lbf/inch in the warp and 440 lbf/inch in the filling.
 3. Service Temperature: Minus 50 to plus 250 deg F.
- F. High-Temperature System, Flexible Connectors: Glass fabric coated with silicone rubber.
1. Minimum Weight: 16 oz./sq. yd.
 2. Tensile Strength: 285 lbf/inch in the warp and 185 lbf/inch in the filling.
 3. Service Temperature: Minus 67 to plus 500 deg F.
- G. High-Corrosive-Environment System, Flexible Connectors: Glass fabric with chemical-resistant coating.
1. Minimum Weight: 14 oz./sq. yd.
 2. Tensile Strength: 450 lbf/inch in the warp and 340 lbf/inch in the filling.
 3. Service Temperature: Minus 67 to plus 500 deg F.
- H. Thrust Limits: Combination coil spring and elastomeric insert with spring and insert in compression, and with a load stop. Include rod and angle-iron brackets for attaching to fan discharge and duct.
1. Frame: Steel, fabricated for connection to threaded rods and to allow for a maximum of 30 degrees of angular rod misalignment without binding or reducing isolation efficiency.
 2. Outdoor Spring Diameter: Not less than 80 percent of the compressed height of the spring at rated load.
 3. Minimum Additional Travel: 50 percent of the required deflection at rated load.
 4. Lateral Stiffness: More than 80 percent of rated vertical stiffness.
 5. Overload Capacity: Support 200 percent of rated load, fully compressed, without deformation or failure.
 6. Elastomeric Element: Molded, oil-resistant rubber or neoprene.
 7. Coil Spring: Factory set and field adjustable for a maximum of 1/4-inch movement at start and stop.

PART 3 - EXECUTION

3.01 INSTALLATION

- A. Install duct accessories according to applicable details in SMACNA's "HVAC Duct Construction Standards - Metal and Flexible" for metal ducts and in NAIMA AH116, "Fibrous Glass Duct Construction Standards," for fibrous-glass ducts.
- B. Install duct accessories of materials suited to duct materials; use galvanized-steel accessories in galvanized-steel and fibrous-glass ducts.
- C. Install volume dampers at points on supply, return, and exhaust systems where branches extend from larger ducts. Where dampers are installed in ducts having duct liner, install dampers with hat channels of same depth as liner, and terminate liner with nosing at hat channel.
 1. Install steel volume dampers in steel ducts.
- D. Set dampers to fully open position before testing, adjusting, and balancing.
- E. Install flexible connectors to connect ducts to equipment.

3.02 FIELD QUALITY CONTROL

- A. Tests and Inspections:
 1. Operate dampers to verify full range of movement.

END OF SECTION 23 33 00

SECTION 23 7313 - INDOOR, SEMI-CUSTOM AIR-HANDLING UNITS

PART 1 - GENERAL

1.1 RELATED DOCUMENTS

- A. Drawings and general provisions of the Contract, including General and Supplementary Conditions and Division 01 Specification Sections, apply to this Section.

1.2 SUMMARY

- A. Section includes insulated, double-wall-casing, indoor, semi-custom air-handling units that are factory assembled using multiple section components, including the following:
 - 1. Casings.
 - 2. Fans, drives, and motors.
 - 3. Coils.
 - 4. Air filtration.
 - 5. Dampers.

1.3 ACTION SUBMITTALS

- A. Product Data: For each air-handling unit.
 - 1. Include construction details, material descriptions, dimensions of individual components and profiles, and finishes.
 - 2. Include rated capacities, operating characteristics, electrical characteristics, and furnished specialties and accessories.
 - 3. Include unit dimensions and weight.
 - 4. Include cabinet material, metal thickness, finishes, insulation, and accessories.
 - 5. Fans:
 - a. Include certified fan-performance curves with system operating conditions indicated.
 - b. Include certified fan-sound power ratings.
 - c. Include fan construction and accessories.
 - d. Include motor ratings, electrical characteristics, and motor accessories.
 - 6. Include certified coil-performance ratings with system operating conditions indicated.
 - 7. Include filters with performance characteristics.
 - 8. Include dampers, including housings, linkages, and operators.
- B. Shop Drawings: For each type and configuration of indoor, semi-custom air handling unit.
 - 1. Include plans, elevations, sections, and mounting and attachment details.
 - 2. Include details of equipment assemblies. Indicate dimensions, weights, loads, required clearances, method of field assembly, components, and location and size of each field connection.
 - 3. Detail fabrication and assembly of indoor, semi-custom air-handling units, as well as procedures and diagrams.
 - 4. Include diagrams for power, signal, and control wiring.

1.4 CLOSEOUT SUBMITTALS

- A. Operation and Maintenance Data: For air-handling units to include in emergency, operation, and maintenance manuals.

1.5 MAINTENANCE MATERIAL SUBMITTALS

- A. Furnish extra materials that match products installed and that are packaged with protective covering for storage and identified with labels describing contents.
 - 1. Filters: One set for each air-handling unit.

1.6 WARRANTY

When warranties are required, verify with Owner's counsel that warranties stated in this article are not less than remedies available to Owner under prevailing local laws.

- A. Warranty: Manufacturer agrees to repair or replace components of indoor, semi-custom air-handling units that fail in materials or workmanship within specified warranty period.
 - 1. Warranty Period: 2 years from date of Substantial Completion.

PART 2 - PRODUCTS

2.1 PERFORMANCE REQUIREMENTS

- A. Electrical Components, Devices, and Accessories: Listed and labeled as defined in NFPA 70, by a qualified testing agency, and marked for intended location and application.
- B. NFPA Compliance: Comply with NFPA 90A for design, fabrication, and installation of air-handling units and components.

2.2 GENERAL DISCRIPTION

- A. Configuration: Fabricate as detailed on drawings.
- B. Performance: See schedules on prints

2.3 UNIT CASINGS

- A. Frame: Modular and providing overall structural integrity without reliance on casing panels for structural support.
- B. Base Rail:
 - 1. Material: Galvanized steel or Welded structural steel
 - 2. Height: Minimum 3 inches.
- C. Casing Joints: Hermetically sealed at each corner and around entire perimeter.

D. Double-Wall Construction:

1. Outside Casing Wall:
 - a. Material, Galvanized Steel.
2. Inside Casing Wall:
 - a. Material, Galvanized Steel.

E. Casing Insulation:

1. Materials: Injected polyurethane foam insulation.
2. Casing Panel R-Value: Minimum R-6.
3. Insulation Thickness: Minimum 1 inch.

F. Panels, Doors, and Windows:

1. Panels:
 - a. Fabrication: Formed and reinforced, double-wall and insulated panels of same materials and thicknesses as casing.
 - b. Fasteners: Two or more camlock type for panel lift-out operation. Arrangement shall allow panels to be opened against airflow
 - c. Gasket: Neoprene, applied around entire perimeters of panel frames.
 - d. Size: Large enough to allow unobstructed access for inspection and maintenance of air-handling unit's internal components.
2. Doors:
 - a. Fabrication: Formed and reinforced, double-wall and insulated panels of same materials and thicknesses as casing.
 - b. Hinges: A minimum of two ball-bearing hinges or stainless-steel piano hinge and two wedge-lever latches, operable from inside and outside. Arrange doors to be opened against airflow. Provide safety latch retainers on doors so that doors do not open uncontrollably.
 - c. Gasket: Neoprene, applied around entire perimeters of panel frames.
 - d. Size: Large enough to allow for unobstructed access for inspection and maintenance of air-handling unit's internal components.
3. Convenience Outlets: One 20-A duplex GFCI receptacle per location with junction box located on outside casing wall.

G. Condensate Drain Pans:

1. Construction:
 - a. Single-wall, stainless-steel sheet.
2. Drain Connection:
 - a. Located at lowest point of pan and sized to prevent overflow.
3. Length: Extend drain pan downstream from leaving face minimum 1 inch.
4. Width: Entire width of water producing device.
5. Depth: A minimum of 2 inches deep.

2.4 FAN, DRIVE, AND MOTOR SECTION

- A. Fan and Drive Assemblies: Statically and dynamically balanced and designed for continuous operation at maximum-rated fan speed and motor horsepower.
- B. Fans: Centrifugal, galvanized steel; mounted on solid-steel shaft.
 - 1. Shafts: With field-adjustable alignment.
 - a. Turned, ground, and polished hot-rolled steel with keyway.
 - 2. Housings: Formed- and reinforced-steel panels to form curved scroll housings with shaped cutoff and spun-metal inlet bell.
 - a. Bracing: Steel angle or channel supports for mounting and supporting fan scroll, wheel, motor, and accessories.
 - 3. Housings, Plenum Fans: Steel frame and panel; fabricated without fan scroll and volute housing. Provide inlet screens for Type SWSI fans.
 - 4. Plenum Fan Arrays: Steel or aluminum frame with inlet cone and structural framing around each fan built into an array of multiple fans.
 - 5. Backward-Inclined, Centrifugal Fan Wheels: Construction with curved inlet flange, backplate, backward-inclined blades welded or riveted to flange and backplate; steel or aluminum hub riveted to backplate and fastened to shaft with setscrews.
 - 6. Forward-Curved, Centrifugal Fan Wheels: Inlet flange, backplate, and shallow blades with inlet and tip curved forward in direction of airflow and mechanically fastened to flange and backplate; steel or aluminum hub swaged to backplate and fastened to shaft with setscrews.
 - 7. Airfoil, Centrifugal Fan Wheels (Plenum Fan Wheels): Smooth-curved inlet flange, backplate, and hollow die-formed airfoil-shaped blades continuously welded at tip flange and backplate; steel hub riveted to backplate and fastened to shaft with setscrews.
 - 8. Mounting: For internal vibration isolation. Factory-mount fans with manufacturer's standard vibration isolation mounting devices.
- C. Drive, Direct: Factory-mounted, direct drive.
- D. Motors:
 - 1. Motor Sizes: Minimum size as indicated. If not indicated, large enough so driven load will not require motor to operate in service factor range above 1.0.
 - 2. Efficiency: Premium Efficient motors as defined in NEMA MG 1.
 - 3. Controllers, Electrical Devices, and Wiring: Comply with requirements for electrical devices and connections specified in electrical Sections.
 - 4. Mount unit-mounted disconnect switches on exterior of unit.
- E. Variable-Frequency Motor Controller: Serving each fan individually in fan array.

2.5 COIL SECTION

- A. General Requirements for Coil Section:
 - 1. Fabricate coil section to allow removal and replacement of coil for maintenance and to allow in-place access for service and maintenance of coil(s).
 - 2. For multizone units, provide air deflectors and air baffles to balance airflow across coils.
 - 3. Coils shall not act as structural component of unit.

B. Heating Coils:

1. Hot-Water Coils:

- a. Piping Connections: Same end of coil.
- b. Tube Material: Copper.
- c. Fin Type: Plate.
- d. Fin Material: Aluminum or Copper.
- e. Headers:
 - 1) Seamless copper tube with brazed joints, prime coated.
- f. Frames: Channel frame
- g. Coil Working-Pressure Ratings: 200 psig, 325 deg F

C. Cooling Coils:

1. Refrigerant Coil:

- a. Piping Connections: Same end of coil.
- b. Tube Material: Copper.
- c. Fin Type: Plate.
- d. Fin Material: Aluminum or Copper.
- e. Headers:
 - 1) Seamless copper tube with brazed joints, prime coated.
- f. Frames: Channel frame
- g. Coil Working-Pressure Ratings: 420 psig, 325 deg F

2.6 AIR FILTRATION SECTION

A. Panel Filters:

- 1. Description: Pleated factory-fabricated, self-supported, disposable air filters with holding frames.
- 2. Filter Unit Class: UL 900.
- 3. Media: Interlaced glass, synthetic or cotton fibers coated with nonflammable adhesive.
- 4. Filter-Media Frame: Beverage board with perforated metal retainer, or metal grid, on outlet side.

B. Side-Access Filter Mounting Frames:

- 1. Particulate Air Filter Frames: Match inner casing and outer casing material, and insulation thickness. Galvanized steel track.
 - a. Prefilters: Incorporate an integral track with same access as primary filter.
 - b. Sealing: Incorporate positive-sealing device to ensure seal between gasketed material on channels to seal top and bottom of filter cartridge frames to prevent bypass of unfiltered air.

2.7 DAMPERS

- A. Outdoor- and Return-Air Dampers: Low-leakage, double-skin, airfoil-blade dampers with compressible jamb seals and extruded-vinyl blade edge seals in opposed-blade arrangement

with operating rods rotating in bearings mounted in a single frame, and with operating rods connected with a common linkage. Leakage rate shall not exceed 4 cfm/sq. ft. at 1-inch wg and 8 cfm/sq. ft. at 4-inch wg , tested, rated, and labeled in accordance with AMCA 511.

- B. Zone Dampers: Two single-blade dampers offset 90 degrees from each other steel operating rod rotating in sintered bronze or nylon bearings mounted in a frame. Provide blade gaskets and edge seals, and mechanically fasten blades to operating rod.
- C. Electronic Damper Operators:
 - 1. Direct-coupled type designed for minimum 60,000 full-stroke cycles at rated torque.
 - 2. Electronic damper position indicator shall have visual scale indicating percent of travel and 2- to 10-V dc, feedback signal.
 - 3. Size dampers for running torque calculated as follows:
 - a. Parallel-Blade Damper with Edge Seals: 7 inch-lb/sq. ft. of damper.
 - b. Opposed-Blade Damper with Edge Seals: 5 inch-lb/sq. ft. of damper.
 - c. Parallel-Blade Damper without Edge Seals: 4 inch-lb/sq. ft of damper.
 - d. Opposed-Blade Damper without Edge Seals: 3 inch-lb/sq. ft. of damper.
 - e. Dampers with 2- to 3-Inch wg of Pressure Drop or Face Velocities of 1000 to 2500 fpm: Increase running torque by 1.5.
 - f. Dampers with 3- to 4-Inch wg of Pressure Drop or Face Velocities of 2500 to 3000 fpm: Increase running torque by 2.0.
 - 4. Coupling: V-bolt and V-shaped, toothed cradle.
 - 5. Overload Protection: Electronic overload or digital rotation-sensing circuitry.
 - 6. Fail-Safe Operation: Mechanical, spring-return mechanism with external, manual gear release on nonspring-return actuators.
 - 7. Proportional Signal: 2- to 10-V dc or 4 to 20 mA, and 2- to 10-V dc position feedback signal.
 - 8. Temperature Rating: Minus 22 to plus 122 deg F.
 - 9. Run Time: 12 seconds open, 5 seconds closed.
- D. Mixing Section: Multiple-blade, air-mixer assembly located immediately downstream of mixing section.
- E. Combination Filter and Mixing Section:
 - 1. Cabinet support members shall hold 2-inch-thick, pleated, flat, throwaway filters.
 - 2. Multiple-blade, air-mixer assembly shall mix air to prevent stratification, located immediately downstream of mixing box.

PART 3 - EXECUTION

3.1 EXAMINATION

- A. Examine areas and conditions, with Installer present, for compliance with requirements for installation tolerances and other conditions affecting performance of the Work.
- B. Examine casing insulation materials and filter media before air-handling unit installation. Reject insulation materials and filter media that are wet, moisture damaged, or mold damaged.

- C. Examine roughing-in for steam, hydronic, and condensate drainage piping systems and electrical services to verify actual locations of connections before installation.
- D. Proceed with installation only after unsatisfactory conditions have been corrected.

3.2 INSTALLATION, GENERAL

- A. Equipment Mounting:
 - 1. Install air-handling units on cast-in-place concrete equipment bases. Coordinate sizes and locations of concrete bases with actual equipment provided. Comply with requirements for equipment bases and foundations specified in Section 033000 "Cast-in-Place Concrete."
- B. Suspended Units: Suspend units from structural-steel support frame using threaded steel rods and spring hangers.
- C. Arrange installation of units to provide access space around air-handling units for service and maintenance.
- D. Do not operate fan system until filters (temporary or permanent) are in place. Replace temporary filters used during construction and testing, with new, clean filters.
- E. Install filter-gauge, static-pressure taps upstream and downstream of filters. Mount filter gauges on outside of filter housing or filter plenum in accessible position. Provide filter gauges on filter banks, installed with separate static-pressure taps upstream and downstream of filters.
- F. Connect duct to air-handling units with flexible connections. Comply with requirements in Section 233300 "Air Duct Accessories."

3.3 PIPING CONNECTIONS

- A. Piping installation requirements are specified in other Sections. Drawings indicate general arrangement of piping, fittings, and specialties.
- B. Where installing piping adjacent to air-handling unit, allow for service and maintenance.
- C. Connect piping to air-handling units mounted on vibration isolators with flexible connectors.
- D. Connect condensate drain pans using NPS 1-1/4, ASTM B88, Type M copper tubing. Extend to nearest equipment or floor drain. Construct deep trap at connection to drain pan and install cleanouts at changes in direction.
- E. Hot- and Chilled-Water Piping: Comply with applicable requirements in Section 232113 "Hydronic Piping." Install shutoff valve and union or flange at each coil supply connection. Install balancing valve and union or flange at each coil return connection.

3.4 ELECTRICAL CONNECTIONS

- A. Connect wiring according to Section 260519 "Low-Voltage Electrical Power Conductors and Cables."

- B. Ground equipment according to Section 260526 "Grounding and Bonding for Electrical Systems."
- C. Install electrical devices furnished by manufacturer, but not factory mounted, according to NFPA 70 and NECA 1.
- D. Install nameplate for each electrical connection, indicating electrical equipment designation and circuit number feeding connection.
 - 1. Nameplate shall be laminated acrylic or melamine plastic signs with a black background and engraved white letters at least 1/2 inch high.

3.5 CONTROL CONNECTIONS

- A. Install control and electrical power wiring to field-mounted control devices.
- B. Connect control wiring according to Section 260523 "Control-Voltage Electrical Power Cables."

3.6 STARTUP SERVICE

- A. Perform startup service.
 - 1. Complete installation and startup checks according to manufacturer's written instructions.
 - 2. Verify that shipping, blocking, and bracing are removed.
 - 3. Verify that unit is secure on mountings and supporting devices and that connections to piping, ducts, and electrical systems are complete. Verify that proper thermal-overload protection is installed in motors, controllers, and switches.
 - 4. Verify proper motor rotation direction, free fan wheel rotation, and smooth bearing operations. Reconnect fan drive system, align belts, and install belt guards.
 - 5. Verify that bearing and other moving parts are lubricated with factory-recommended lubricants.
 - 6. Verify that outdoor- and return-air mixing dampers open and close, and maintain minimum outdoor-air setting.
 - 7. Comb coil fins for parallel orientation.
 - 8. Install new, clean filters.
 - 9. Verify that manual and automatic volume control and fire and smoke dampers in connected duct systems are in fully open position.
- B. Starting procedures for air-handling units include the following:
 - 1. Energize motor; verify proper operation of motor, drive system, and fan wheel. Adjust fan to indicated rpm.
 - 2. Measure and record motor electrical values for voltage and amperage.
 - 3. Manually operate dampers from fully closed to fully open position and record fan performance.

3.7 ADJUSTING

- A. Adjust damper linkages for proper damper operation.
- B. Comply with requirements in Section 230593 "Testing, Adjusting, and Balancing for HVAC" for air-handling system testing, adjusting, and balancing.

- C. Occupancy Adjustments: When requested within 12 months from date of Substantial Completion, provide on-site assistance in adjusting system to suit actual occupied conditions. Provide up to two visits to Project during other-than-normal occupancy hours for this purpose.

3.8 CLEANING

- A. After completing system installation and testing, adjusting, and balancing air-handling unit and air-distribution systems and after completing startup service, clean air-handling units internally to remove foreign material and construction dirt and dust. Clean fan wheels, cabinets, dampers, coils, and filter housings, and install new, clean filters.

3.9 FIELD QUALITY CONTROL

- A. Perform the following tests and inspections:
 - 1. Leak Test: After installation, fill water and steam coils with water, and test coils and connections for leaks.
 - 2. Fan Operational Test: After electrical circuitry has been energized, start units to confirm proper motor rotation and unit operation.
 - 3. Test and adjust controls and safeties. Replace damaged and malfunctioning controls and equipment.
- B. Prepare test and inspection reports.

3.10 DEMONSTRATION

- A. Train Owner's maintenance personnel to adjust, operate, and maintain air-handling units.

END OF SECTION 237313

SECTION 23 8219 - FAN COIL UNITS

PART 1 - GENERAL

1.1 RELATED DOCUMENTS

- A. Drawings and general provisions of the Contract, including General and Supplementary Conditions and Division 01 Specification Sections, apply to this Section.

1.2 SUMMARY

- A. Section Includes:
 - 1. Ducted fan coil units and accessories.

1.3 ACTION SUBMITTALS

- A. Product Data: For each type of product.
 - 1. Include rated capacities, operating characteristics, and furnished specialties and accessories.
- B. Shop Drawings:
 - 1. Include details of equipment assemblies. Indicate dimensions, weights, loads, required clearances, method of field assembly, components, and location and size of each field connection.
 - 2. Include diagrams for power, signal, and control wiring.

1.4 CLOSEOUT SUBMITTALS

- A. Operation and Maintenance Data: For fan coil units to include in emergency, operation, and maintenance manuals.
 - 1. In addition to items specified in Section 017823 "Operation and Maintenance Data," include the following:
 - a. Maintenance schedules and repair part lists for motors, coils, integral controls, and filters.

1.5 QUALITY ASSURANCE

- A. Comply with NFPA 70.
- B. ASHRAE Compliance: Applicable requirements in ASHRAE 62.1, Section 5 - "Systems and Equipment" and Section 7 - "Construction and Startup."
- C. ASHRAE/IES 90.1 Compliance: Applicable requirements in ASHRAE/IES 90.1, Section 6 - "Heating, Ventilating, and Air-Conditioning."

1.6 COORDINATION

- A. Coordinate layout and installation of fan coil units and suspension system components with other construction that penetrates or is supported by ceilings, including light fixtures, HVAC equipment, fire-suppression-system components, and partition assemblies.

1.7 WARRANTY

- A. Special Warranty: Manufacturer agrees to repair or replace components of condensing units that fail in materials or workmanship within specified warranty period..
 - 1. Warranty Period: 2 years from date of Substantial Completion.

PART 2 - PRODUCTS

2.1 SYSTEM DESCRIPTION

- A. Electrical Components, Devices, and Accessories: Listed and labeled as defined in NFPA 70, by a qualified testing agency, and marked for intended location and application.
- B. Factory-packaged and -tested units rated according to AHRI 440, ASHRAE 33, and UL 1995.

2.2 DUCTED FAN COIL UNITS

- A. Fan Coil Type and Arrangement: A. The fan coil shall be furnished as a draw-through cooling coil with a heating coil in reheat position
- B. General Construction:
 - 1. The units shall include a chassis, coil(s), fan deck with blower(s)/blower housing and motor(s). Steel parts exposed to moisture shall be galvanized and insulated to prevent condensation. The complete fan assembly shall be easily removable for service and maintenance. A quick-connect motor electric plug shall be provided.
 - 2. Unit shall be supplied with return plenum complete with filter frame and filter. The plenum shall be fabricated of 18 gauge galvanized steel. The inside plenum surface shall be insulated with 1/2" matt-faced fiberglass insulation. Plenum insulation shall meet minimum K value of 0.24 (BTU-in)/(hr-ft²-F) and rated for maximum air velocity of 5000 fpm. Fiberglass insulation conforms to:
 - a. ASTM C1071 (including C665)
 - b. UL 181 for erosion
 - c. 25/50 rating for flame spread/smoke developed per ASTM E-84, UL 723 and NFPA 90A
- C. Supply Fan:
 - 1. Supply fans shall be a DWDI forward-curved type. Fan assemblies including fan, motor and sheaves shall be dynamically balanced by the manufacturer on all three planes at all bearing supports. Manufacturer must ensure maximum fan RPM is below the first critical speed.
 - 2. The complete fan assembly, including motor and main drain pan shall be easily removable.
 - 3. Units shall be certified in accordance with the Room Fan Coil Unit certification program that is based on ARI Standard 440.

4. An ECM blower motor shall be provided on all units. Factory motor wiring shall be set for optimum fan performance. The unit shall be shipped at one fixed setting. The ECM motor shall utilize a permanent magnet rotor, which is connected to the shaft through resilient rings to absorb high frequency torque ripple. ECM motor shall be programmed for constant CFM or constant torque.
- D. Electrical:
1. Supply fans shall be driven by permanent split-capacitor motors that are run-tested in the assembled unit and permanently lubricated. All motors shall have integral thermal overload protection with a maximum ambient operating temperature of 104°F. Motors shall be capable of starting at 78 percent of rated voltage and operating at 90 percent of rated voltage on all speed settings. Motors can operate up to 10 percent overvoltage.
 2. Motor wires shall include a quick-disconnect motor plug.
- E. Cooling Coils:
1. Coiling performance shall be as specified on the unit schedule.
 2. Coil fins shall have full drawn collars to provide a continuous surface cover over the entire tube for maximum heat transfer. Seamless copper tubes shall be mechanically expanded into the fins to provide a continuous primary-to-secondary compression bond over the entire finned length for maximum heat transfer rates. Bare copper tubes shall not be visible between fins.
 3. Coils shall be provided with headers of seamless copper tubing with intruded tube holes to permit expansion and contraction without creating undue stress or strain. Coil connections shall be copper sweat connections with connection size to be determined by manufacturer based upon the most efficient coil circuiting. Drain connections shall be furnished on the coil connection, external to the cabinet. Drain connections shall be provided at the lowest point.
 4. All steel parts exposed to moisture shall be galvanized.
 5. Unit shall include a noncorrosive, stainless steel main drain pan, positively sloped in every plane and insulated with closed-cell insulation. The drain pan shall be designed to ensure no pooling of condensate water per ASHRAE 62.2.
- F. Heating Coils:
1. Heating performance shall be as specified on the unit schedule.
 2. Coil fins shall have full drawn collars to provide a continuous surface cover over the entire tube for maximum heat transfer. Seamless copper tubes shall be mechanically expanded into the fins to provide a continuous primary-to-secondary compression bond over the entire finned length for maximum heat transfer rates. Bare copper tubes shall not be visible between fins.
 3. Coils shall be provided with headers of seamless copper tubing with intruded tube holes to permit expansion and contraction without creating undue stress or strain. Coil connections shall be copper sweat connections with connection size to be determined by manufacturer based upon the most efficient coil circuiting. Drain connections shall be furnished on the coil connection, external to the cabinet. Drain connections shall be provided at the lowest point.
- G. Filters: Filters shall be 1" (25 mm) throwaway. They shall be concealed from sight and easily removable.
- H. Controls:
1. Reference drawings for control sequences and provide necessary hardware to achieve sequence of operations

PART 3 - EXECUTION

3.1 EXAMINATION

- A. Examine areas, with Installer present, to receive fan coil units for compliance with requirements for installation tolerances and other conditions affecting performance of the Work.
- B. Examine roughing-in for piping and electrical connections to verify actual locations before fan coil unit installation.
- C. Proceed with installation only after unsatisfactory conditions have been corrected.

3.2 INSTALLATION

- A. Install fan coil units level and plumb.
- B. Install fan coil units to comply with NFPA 90A.
- C. Suspend fan coil units from structure with elastomeric hangers.
- D. Verify locations of thermostats, humidistats, and other exposed control sensors with Drawings and room details before installation. Install devices 48 inches above finished floor.
- E. Install new filters in each fan coil unit within two weeks after Substantial Completion.

3.3 CONNECTIONS

- A. Piping installation requirements are specified in other Sections. Drawings indicate general arrangement of piping, fittings, and specialties. Specific connection requirements are as follows:
 - 1. Install piping adjacent to machine to allow service and maintenance.
 - 2. Connect piping to fan coil unit factory hydronic piping package. Install piping package if shipped loose.
 - 3. Connect condensate drain to indirect waste.
 - a. Install condensate trap of adequate depth to seal against fan pressure. Install cleanouts in piping at changes of direction.
- B. Connect supply-air and return-air ducts to fan coil units with flexible duct connectors specified in Section 233300 "Air Duct Accessories." Comply with safety requirements in UL 1995 for duct connections.
- C. Ground equipment according to Section 260526 "Grounding and Bonding for Electrical Systems."
- D. Connect wiring according to Section 260519 "Low-Voltage Electrical Power Conductors and Cables."

3.4 FIELD QUALITY CONTROL

- A. Perform the following tests and inspections:

1. Operational Test: After electrical circuitry has been energized, start units to confirm proper motor rotation and unit operation.
2. Test and adjust controls and safety devices. Replace damaged and malfunctioning controls and equipment.

B. Remove and replace malfunctioning units and retest as specified above.

C. Prepare test and inspection reports.

3.5 ADJUSTING

A. Adjust initial temperature and humidity set points.

B. Occupancy Adjustments: When requested within 12 months of date of Substantial Completion, provide on-site assistance in adjusting system to suit actual occupied conditions. Provide up to two visits to Project during other-than-normal occupancy hours for this purpose.

3.6 DEMONSTRATION

A. Train Owner's maintenance personnel to adjust, operate, and maintain fan coil units.

END OF SECTION 238219

SECTION 26 0519 - LOW-VOLTAGE ELECTRICAL POWER CONDUCTORS AND CABLES

PART 1 - GENERAL

1.1 SUMMARY

- A. Section Includes:
1. Copper building wire rated 600 V or less.
 2. Aluminum building wire rated 600 V or less.
 3. Metal-clad cable, Type MC, rated 600 V or less.
 4. Fire-alarm wire and cable.
 5. Connectors, splices, and terminations rated 600 V and less.

1.2 ACTION SUBMITTALS

- A. Product Data: For each type of product.
- B. Product Schedule: Indicate type, use, location, and termination locations.

1.3 INFORMATIONAL SUBMITTALS

- A. Field quality-control reports.

PART 2 - PRODUCTS

2.1 COPPER BUILDING WIRE

- A. Description: Flexible, insulated and uninsulated, drawn copper current-carrying conductor with an overall insulation layer or jacket, or both, rated 600 V or less.
- B. Manufacturers: Subject to compliance with requirements, available manufacturers offering products that may be incorporated into the Work include, but are not limited to the following:
1. Encore Wire Corporation.
 2. Southwire Company.
- C. Standards:
1. Listed and labeled as defined in NFPA 70, by a qualified testing agency, and marked for intended location and use.
 2. RoHS compliant.
 3. Conductor and Cable Marking: Comply with wire and cable marking according to UL's "Wire and Cable Marking and Application Guide."
- D. Conductors: Copper, complying with ASTM B3 for bare annealed copper and with ASTM B8 and ASTM B496 for stranded conductors.
- E. Conductor Insulation:
1. Type RHH and Type RHW-2: Comply with UL 44.
 2. Type THHN and Type THWN-2: Comply with UL 83.

3. Type XHHW-2: Comply with UL 44.

2.2 ALUMINUM BUILDING WIRE

- A. Description: Flexible, insulated and uninsulated, drawn aluminum current-carrying conductor with an overall insulation layer or jacket, or both, rated 600 V or less.
- B. Manufacturers: Subject to compliance with requirements, available manufacturers offering products that may be incorporated into the Work include, but are not limited to the following:
 1. Encore Wire Corporation.
 2. Southwire Company.
- C. Standards:
 1. Listed and labeled as defined in NFPA 70, by a qualified testing agency, and marked for intended location and use.
 2. RoHS compliant.
 3. Conductor and Cable Marking: Comply with wire and cable marking according to UL's "Wire and Cable Marking and Application Guide."
- D. Conductors: Aluminum, complying with ASTM B800 and ASTM B801.
- E. Conductor Insulation:
 1. Type RHH and Type RHW-2: Comply with UL 44.
 2. Type THHN and Type THWN-2: Comply with UL 83.
 3. Type XHHW-2: Comply with UL 44.

2.3 METAL-CLAD CABLE, TYPE MC

- A. Description: A factory assembly of one or more current-carrying insulated conductors in an overall metallic sheath.
- B. Manufacturers: Subject to compliance with requirements, available manufacturers offering products that may be incorporated into the Work include, but are not limited to the following:
 1. Encore Wire Corporation.
 2. Southwire Company.
- C. Standards:
 1. Listed and labeled as defined in NFPA 70, by a qualified testing agency, and marked for intended location and use.
 2. Comply with UL 1569.
 3. RoHS compliant.
 4. Conductor and Cable Marking: Comply with wire and cable marking according to UL's "Wire and Cable Marking and Application Guide."
- D. Circuits:
 1. Single circuit and multicircuit with color-coded conductors.
 2. Power-Limited Fire-Alarm Circuits: Comply with UL 1424.

- E. Conductors: Copper, complying with ASTM B3 for bare annealed copper and with ASTM B8 for stranded conductors.
- F. Ground Conductor: Insulated.
- G. Conductor Insulation:
 - 1. Type TFN/THHN/THWN-2: Comply with UL 83.
 - 2. Type XHHW-2: Comply with UL 44.
- H. Armor: Aluminum, interlocked.
- I. Jacket: PVC applied over armor.

2.4 FIRE-ALARM WIRE AND CABLE

- A. Manufacturers: Subject to compliance with requirements, available manufacturers offering products that may be incorporated into the Work include, but are not limited to the following:
 - 1. Allied Wire & Cable Inc.
 - 2. CommScope, Inc.
- B. General Wire and Cable Requirements: NRTL listed and labeled as complying with NFPA 70, Article 760.
- C. Signaling Line Circuits: Twisted, shielded pair, not less than No. 18 AWG.
 - 1. Circuit Integrity Cable: Twisted shielded pair, NFPA 70, Article 760, Classification CI, for power-limited fire-alarm signal service Type FPL. NRTL listed and labeled as complying with UL 1424 and UL 2196 for a two-hour rating.
- D. Non-Power-Limited Circuits: Solid-copper conductors with 600-V rated, 75 deg C, color-coded insulation, and complying with requirements in UL 2196 for a two-hour rating.
 - 1. Low-Voltage Circuits: No. 16 AWG, minimum, in pathway.
 - 2. Line-Voltage Circuits: No. 12 AWG, minimum, in pathway.
 - 3. Multiconductor Armored Cable: NFPA 70, Type MC, copper conductors, Type TFN/THHN conductor insulation, copper drain wire, copper armor with outer jacket with red identifier stripe, NRTL listed for fire-alarm and cable tray installation, plenum rated.

2.5 CONNECTORS AND SPLICES

- A. Description: Factory-fabricated connectors, splices, and lugs of size, ampacity rating, material, type, and class for application and service indicated; listed and labeled as defined in NFPA 70, by a qualified testing agency, and marked for intended location and use.
- B. Manufacturers: Subject to compliance with requirements, available manufacturers offering products that may be incorporated into the Work include, but are not limited to the following:
 - 1. 3M Electrical Products.
 - 2. NSi Industries LLC.

- C. Jacketed Cable Connectors: For steel and aluminum jacketed cables, zinc die-cast with set screws, designed to connect conductors specified in this Section.
- D. Lugs: One piece, seamless, designed to terminate conductors specified in this Section.
 - 1. Material: Copper.
 - 2. Type: Two hole with long barrels.
 - 3. Termination: Crimp.

PART 3 - EXECUTION

3.1 CONDUCTOR MATERIAL APPLICATIONS

- A. Feeders:
 - 1. Copper; solid for No. 10 AWG and smaller; stranded for No. 8 AWG and larger.
 - 2. Copper for feeders smaller than No. 4 AWG; copper for feeders No. 4 AWG and larger. Conductors shall be solid for No. 10 AWG and smaller; stranded for No. 8 AWG and larger.
- B. Branch Circuits:
 - 1. Copper, Solid for No. 12 AWG and smaller; stranded for No. 10 AWG and larger.
- C. Power-Limited Fire Alarm and Control: Solid for No. 12 AWG and smaller.

3.2 CONDUCTOR INSULATION AND MULTICONDUCTOR CABLE APPLICATIONS AND WIRING METHODS

- A. Service Entrance: Type THHN/THWN-2, single conductors in raceway or Type XHHW-2, single conductors in raceway.
- B. Exposed Feeders: Type THHN/THWN-2, single conductors in raceway or Type XHHW-2, single conductors in raceway.
- C. Feeders Concealed in Ceilings, Walls, Partitions, and Crawlspace: Type THHN/THWN-2, single conductors in raceway.
- D. Feeders Concealed in Concrete, below Slabs-on-Grade, and Underground: Type THHN/THWN-2, single conductors in raceway or Type XHHW-2, single conductors in raceway.
- E. Exposed Branch Circuits, Including in Crawlspace: Type THHN/THWN-2, single conductors in raceway.
- F. Branch Circuits Concealed in Ceilings, Walls, and Partitions: Type THHN/THWN-2, single conductors in raceway.
- G. Branch Circuits Concealed in Concrete, below Slabs-on-Grade, and Underground: Type THHN/THWN-2, single conductors in raceway or Type XHHW-2, single conductors in raceway.

3.3 INSTALLATION OF CONDUCTORS AND CABLES

- A. Conceal cables in finished walls, ceilings, and floors unless otherwise indicated.
- B. Complete raceway installation between conductor and cable termination points according to Section 260533 "Raceways and Boxes for Electrical Systems" prior to pulling conductors and cables.
- C. Use manufacturer-approved pulling compound or lubricant where necessary; compound used must not deteriorate conductor or insulation. Do not exceed manufacturer's recommended maximum pulling tensions and sidewall pressure values.
- D. Use pulling means, including fish tape, cable, rope, and basket-weave wire/cable grips, that will not damage cables or raceway.
- E. Install exposed cables parallel and perpendicular to surfaces of exposed structural members, and follow surface contours where possible.
- F. Support cables according to Section 260529 "Hangers and Supports for Electrical Systems."

3.4 INSTALLATION OF FIRE-ALARM WIRE AND CABLE

- A. Comply with NECA 1 and NFPA 72.
- B. Wiring Method: Install wiring in metal pathway according to Section 280528 "Pathways for Electronic Safety and Security."
 - 1. Install plenum cable in environmental airspaces, including plenum ceilings.
 - 2. Fire-alarm circuits and equipment control wiring associated with fire-alarm system shall be installed in a dedicated pathway system.
 - a. Cables and pathways used for fire-alarm circuits, and equipment control wiring associated with fire-alarm system, may not contain any other wire or cable.
 - 3. Fire-Rated Cables: Use of two-hour, fire-rated fire-alarm cables, NFPA 70, Types MI and CI, is permitted.
 - 4. Signaling Line Circuits: Power-limited fire-alarm cables shall not be installed in the same cable or pathway as signaling line circuits.
- C. Wiring within Enclosures: Separate power-limited and non-power-limited conductors as recommended by manufacturer. Install conductors parallel with or at right angles to sides and back of the enclosure. Bundle, lace, and train conductors to terminal points with no excess. Connect conductors that are terminated, spliced, or interrupted in any enclosure associated with fire-alarm system to terminal blocks. Mark each terminal according to system's wiring diagrams. Make all connections with approved crimp-on terminal spade lugs, pressure-type terminal blocks, or plug connectors.
- D. Cable Taps: Use numbered terminal strips in junction, pull, and outlet boxes, cabinets, or equipment enclosures where circuit connections are made.
- E. Color-Coding: Color-code fire-alarm conductors differently from the normal building power wiring. Use one color-code for alarm circuit wiring and another for supervisory circuits. Color-code audible alarm-indicating circuits differently from alarm-initiating circuits. Use different

colors for visible alarm-indicating devices. Paint fire-alarm system junction boxes and covers red.

- F. Risers: Install at least two vertical cable risers to serve the fire-alarm system. Separate risers in close proximity to each other with a minimum one-hour-rated wall, so the loss of one riser does not prevent receipt or transmission of signals from other floors or zones.
- G. Wiring to Remote Alarm Transmitting Device: 1-inch (25-mm) conduit between the fire-alarm control panel and the transmitter. Install number of conductors and electrical supervision for connecting wiring as needed to suit monitoring function.

3.5 CONNECTIONS

- A. Tighten electrical connectors and terminals according to manufacturer's published torque-tightening values. If manufacturer's torque values are not indicated, use those specified in UL 486A-486B.
- B. Make splices, terminations, and taps that are compatible with conductor material and that possess equivalent or better mechanical strength and insulation ratings than unspliced conductors.
 - 1. Use oxide inhibitor in each splice, termination, and tap for aluminum conductors.
- C. Wiring at Outlets: Install conductor at each outlet, with at least 6 inches (150 mm) of slack.
- D. Comply with requirements in Section 284621.11 "Addressable Fire-Alarm Systems" for connecting, terminating, and identifying wires and cables.

3.6 IDENTIFICATION

- A. Identify and color-code conductors and cables according to Section 260553 "Identification for Electrical Systems."
- B. Identify each spare conductor at each end with identity number and location of other end of conductor, and identify as spare conductor.

3.7 SLEEVE AND SLEEVE-SEAL INSTALLATION FOR ELECTRICAL PENETRATIONS

- A. Install sleeves and sleeve seals at penetrations of exterior floor and wall assemblies. Comply with requirements in Section 260544 "Sleeves and Sleeve Seals for Electrical Raceways and Cabling."

3.8 FIRESTOPPING

- A. Apply firestopping to electrical penetrations of fire-rated floor and wall assemblies to restore original fire-resistance rating of assembly according to Section 078413 "Penetration Firestopping."

END OF SECTION 26 05 19

SECTION 26 0523 - CONTROL-VOLTAGE ELECTRICAL POWER CABLES

PART 1 - GENERAL

1.1 SUMMARY

- A. Section Includes:
 - 1. Backboards.
 - 2. Category 5e balanced twisted pair cable.
 - 3. Balanced twisted pair cabling hardware.
 - 4. RS-485 cabling.
 - 5. Low-voltage control cabling.
 - 6. Control-circuit conductors.

1.2 DEFINITIONS

- A. Low Voltage: As defined in NFPA 70 for circuits and equipment operating at less than 50 V or for remote-control and signaling power-limited circuits.

1.3 ACTION SUBMITTALS

- A. Product Data: For each type of product.

1.4 INFORMATIONAL SUBMITTALS

- A. Qualification Data: For testing agency, RCDD, layout technician, installation supervisor, and field inspector.
- B. Source quality-control reports.
- C. Field quality-control reports.

1.5 QUALITY ASSURANCE

- A. Testing Agency Qualifications: Accredited by NETA.
 - 1. Testing Agency's Field Supervisor: Currently certified by BICSI as an RCDD.

PART 2 - PRODUCTS

2.1 PERFORMANCE REQUIREMENTS

- A. Electrical Components, Devices, and Accessories: Listed and labeled as defined in NFPA 70, by a qualified testing agency, and marked for intended location and application.

- B. Flame Travel and Smoke Density in Plenums: As determined by testing identical products according to NFPA 262, by a qualified testing agency. Identify products for installation in plenums with appropriate markings of applicable testing agency.
 - 1. Flame Travel Distance: 60 inches (1520 mm) or less.
 - 2. Peak Optical Smoke Density: 0.5 or less.
 - 3. Average Optical Smoke Density: 0.15 or less.
- C. Flame Travel and Smoke Density for Riser Cables in Non-Plenum Building Spaces: As determined by testing identical products according to UL 1666.
- D. Flame Travel and Smoke Density for Cables in Non-Riser Applications and Non-Plenum Building Spaces: As determined by testing identical products according to UL 1685.
- E. RoHS compliant.

2.2 BACKBOARDS

- A. Description: Plywood, fire-retardant treated, 3/4 by 48 by 96 inches (19 by 1220 by 2440 mm). Comply with requirements for plywood backing panels in Section 061000 "Rough Carpentry."
- B. Painting: Paint plywood on all sides and edges with flat black alkyd paint. Comply with requirements in Section 099123 "Interior Painting."

2.3 CATEGORY 5e BALANCED TWISTED PAIR CABLE

- A. Description: Four-pair, balanced-twisted pair cable, certified to meet transmission characteristics of Category 5e cable at frequencies up to 100 MHz.
- B. Manufacturers: Subject to compliance with requirements, available manufacturers offering products that may be incorporated into the Work include, but are not limited to the following:
 - 1. Belden CDT Networking Division/NORDX.
 - 2. Berk-Tek Leviton; a Nexans/Leviton alliance.
 - 3. CommScope, Inc.
- C. Standard: Comply with ICEA S-90-661, NEMA WC 63.1, and TIA-568-C.2 for Category 5e cables.
- D. Conductors: 100-ohm, 24 AWG solid copper.
- E. Shielding/Screening: Unshielded twisted pairs (UTP).
- F. Cable Rating: Plenum.
- G. Jacket: thermoplastic.

2.4 BALANCED TWISTED PAIR CABLE HARDWARE

- A. Description: Hardware designed to connect, splice, and terminate balanced twisted pair copper communications cable.

- B. Manufacturers: Subject to compliance with requirements, available manufacturers offering products that may be incorporated into the Work include, but are not limited to the following:
 - 1. Belden CDT Networking Division/NORDX.
 - 2. Berk-Tek Leviton; a Nexans/Leviton alliance.
 - 3. CommScope, Inc.
- C. General Requirements for Balanced Twisted Pair Cable Hardware:
 - 1. Comply with the performance requirements of Category 6.
 - 2. Comply with TIA-568-C.2, IDC type, with modules designed for punch-down caps or tools.
 - 3. Cables shall be terminated with connecting hardware of same category or higher.
- D. Source Limitations: Obtain balanced twisted pair cable hardware from single source from single manufacturer.
- E. Connecting Blocks: 110-style IDC for Category 6. Provide blocks for the number of cables terminated on the block, plus 25 percent spare, integral with connector bodies, including plugs and jacks where indicated.
- F. Cross-Connect: Modular array of connecting blocks arranged to terminate building cables and permit interconnection between cables.
 - 1. Number of Terminals per Field: One for each conductor in assigned cables.
- G. Patch Panel: Modular panels housing numbered jack units with IDC-type connectors at each jack location for permanent termination of pair groups of installed cables.
 - 1. Features:
 - a. Universal T568A and T568B wiring labels.
 - b. Labeling areas adjacent to conductors.
 - c. Replaceable connectors.
 - d. 24 or 48 ports.
 - 2. Construction: 16-gauge steel and mountable on 19-inch (483 mm) equipment racks.
 - 3. Number of Jacks per Field: One for each four-pair conductor group of indicated cables, plus spares and blank positions adequate to suit specified expansion criteria.
- H. Patch Cords: Factory-made, four-pair cables in 48-inch (1200-mm) lengths; terminated with an eight-position modular plug at each end.
 - 1. Patch cords shall have bend-relief-compliant boots and color-coded icons to ensure performance. Patch cords shall have latch guards to protect against snagging.
 - 2. Patch cords shall have color-coded boots for circuit identification.
- I. Plugs and Plug Assemblies:
 - 1. Male; eight position; color-coded modular telecommunications connector designed for termination of a single four-pair 100-ohm unshielded or shielded balanced twisted pair cable.
 - 2. Comply with IEC 60603-7-1, IEC 60603-7-2, IEC 60603-7-3, IEC 60603-7-4, and IEC 60603-7.5.
 - 3. Marked to indicate transmission performance.

J. Jacks and Jack Assemblies:

1. Female; eight position; modular; fixed telecommunications connector designed for termination of a single four-pair 100-ohm unshielded or shielded balanced twisted pair cable.
2. Designed to snap-in to a patch panel or faceplate.
3. Standards.
 - a. Category 5e, unshielded balanced twisted pair cable shall comply with IEC 60603-7-2.
 - b. Category 5e, shielded balanced twisted pair cable shall comply with IEC 60603-7-3.
 - c. Category 6, unshielded balanced twisted pair cable shall comply with IEC 60603-7-4.
 - d. Category 6, shielded balanced twisted pair cable shall comply with IEC 60603-7.5.
 - e. Category 6a, unshielded balanced twisted pair cable shall comply with IEC 60603-7-41.
 - f. Category 6a, shielded balanced twisted pair cable shall comply with IEC 60603-7.51.
4. Marked to indicate transmission performance.

K. Faceplate:

1. Four port, vertical single gang faceplates designed to mount to single gang wall boxes.
2. Eight port, vertical double gang faceplates designed to mount to double gang wall boxes.
3. Plastic Faceplate: High-impact plastic. Coordinate color with Section 262726 "Wiring Devices."
4. Metal Faceplate: Stainless steel, complying with requirements in Section 262726 "Wiring Devices."
5. For use with snap-in jacks accommodating any combination of balanced twisted pair, optical fiber, and coaxial work area cords.
 - a. Flush mounting jacks, positioning the cord at a 45-degree angle.

L. Legend:

1. Machine printed, in the field, using adhesive-tape label.
2. Snap-in, clear-label covers and machine-printed paper inserts.

2.5 TWIN-AXIAL DATA HIGHWAY CABLE

A. Plenum-Rated Cable: NFPA 70, Type CMP.

1. Paired, pairs, No. 20 AWG, stranded (7x28) tinned-copper conductors.
2. Plastic insulation.
3. Individual aluminum foil-polyester tape shielded pairs with 100 percent shield coverage.
4. Plastic jacket.
5. Pairs are cabled on common axis with No. 24 AWG, stranded (7x32) tinned-copper drain wire.
6. Flame Resistance: Comply with NFPA 262.

2.6 RS-232 CABLE

- A. Manufacturers: Subject to compliance with requirements, available manufacturers offering products that may be incorporated into the Work include, but are not limited to the following:
 - 1. Belden Inc.
 - 2. Southwire Company.
- B. PVC-Jacketed, TIA 232-F:
 - 1. Nine, No. 22 AWG, stranded (7x30) tinned copper conductors.
 - 2. Polypropylene insulation.
 - 3. Aluminum foil-polyester tape shield with 100 percent shield coverage.
 - 4. PVC jacket.
 - 5. Conductors are cabled on common axis with No. 24 AWG, stranded (7x32) tinned copper drain wire.
 - 6. NFPA 70 Type: Type CM.
 - 7. Flame Resistance: Comply with UL 1581.
- C. Plenum-Type, TIA 232-F:
 - 1. Nine, No. 22 AWG, stranded (7x30) tinned copper conductors.
 - 2. PE insulation.
 - 3. Aluminum foil-polyester tape shield with 100 percent shield coverage.
 - 4. Fluorinated ethylene propylene jacket.
 - 5. Conductors are cabled on common axis with No. 24 AWG, stranded (7x32) tinned copper drain wire.
 - 6. Flame Resistance: Comply with NFPA 262.

2.7 RS-485 CABLE

- A. Plenum-Rated Cable: NFPA 70, Type CMP.
 - 1. Paired, two pairs, No. 22 AWG, stranded (7x30) tinned-copper conductors.
 - 2. Fluorinated ethylene propylene insulation.
 - 3. Unshielded.
 - 4. Fluorinated ethylene propylene jacket.
 - 5. Flame Resistance: NFPA 262.

2.8 LOW-VOLTAGE CONTROL CABLE

- A. Plenum-Rated, Paired Cable: NFPA 70, Type CMP.
 - 1. Multi-pair, twisted, No. 16 AWG, stranded (19x29) tinned-copper conductors.
 - 2. PVC insulation.
 - 3. Unshielded.
 - 4. PVC jacket.
 - 5. Flame Resistance: Comply with NFPA 262.

2.9 CONTROL-CIRCUIT CONDUCTORS

- A. Manufacturers: Subject to compliance with requirements, available manufacturers offering products that may be incorporated into the Work include, but are not limited to the following:
 - 1. Encore Wire Corporation.
 - 2. Southwire Company.
- B. Class 1 Control Circuits: Stranded copper, Type THHN/THWN-2, complying with UL 83 in raceway.
- C. Class 2 Control Circuits: Stranded copper, Type THHN/THWN-2, complying with UL 83 in raceway.
- D. Class 3 Remote-Control and Signal Circuits: Stranded copper, Type THHN/THWN-2, complying with UL 83 in raceway.
- E. Class 2 Control Circuits and Class 3 Remote-Control and Signal Circuits That Supply Critical Circuits: Circuit Integrity (CI) cable.
 - 1. Smoke control signaling and control circuits.

2.10 FIRE-ALARM WIRE AND CABLE

- A. Manufacturers: Subject to compliance with requirements, available manufacturers offering products that may be incorporated into the Work include, but are not limited to the following:
 - 1. Superior Essex Inc.
 - 2. West Penn Wire.
- B. General Wire and Cable Requirements: NRTL listed and labeled as complying with NFPA 70, Article 760.
- C. Signaling Line Circuits: Twisted, shielded pair, not less than No. 18 AWG.
 - 1. Circuit Integrity Cable: Twisted shielded pair, NFPA 70, Article 760, Classification CI, for power-limited fire-alarm signal service Type FPL. NRTL listed and labeled as complying with UL 1424 and UL 2196 for a two-hour rating.
- D. Non-Power-Limited Circuits: Solid-copper conductors with 600-V rated, 75 deg C, color-coded insulation, and complying with requirements in UL 2196 for a two-hour rating.
 - 1. Low-Voltage Circuits: No. 16 AWG, minimum, in pathway.
 - 2. Line-Voltage Circuits: No. 12 AWG, minimum, in pathway.
 - 3. Multiconductor Armored Cable: NFPA 70, Type MC, copper conductors, Type TFN/THHN conductor insulation, copper drain wire, copper armor with outer jacket with red identifier stripe, NRTL listed for fire-alarm and cable tray installation, plenum rated.

2.11 SOURCE QUALITY CONTROL

- A. Factory test balanced twisted pair cables according to TIA-568-C.2.
- B. Cable will be considered defective if it does not pass tests and inspections.

- C. Prepare test and inspection reports.

PART 3 - EXECUTION

3.1 EXAMINATION

- A. Test cables on receipt at Project site.
 - 1. Test each pair of twisted pair cable for open and short circuits.

3.2 INSTALLATION OF RACEWAYS AND BOXES

- A. Comply with requirements in Section 260533 "Raceways and Boxes for Electrical Systems" for raceway selection and installation requirements for boxes, conduits, and wireways as supplemented or modified in this Section.
 - 1. Outlet boxes shall be no smaller than 2 inches (50 mm) wide, 3 inches (75 mm) high, and 2-1/2 inches (64 mm) deep.
 - 2. Outlet boxes shall be no smaller than 4 inches (102 mm) square by 2-1/8 inches (53 mm) deep with extension ring sized to bring edge of ring to within 1/8 inch (3.1 mm) of the finished wall surface.
 - 3. Flexible metal conduit shall not be used.
- B. Comply with TIA-569-D for pull-box sizing and length of conduit and number of bends between pull points.
- C. Install manufactured conduit sweeps and long-radius elbows if possible.
- D. Raceway Installation in Equipment Rooms:
 - 1. Position conduit ends adjacent to a corner on backboard if a single piece of plywood is installed, or in the corner of the room if multiple sheets of plywood are installed around perimeter walls of the room.
 - 2. Install cable trays to route cables if conduits cannot be located in these positions.
 - 3. Secure conduits to backboard if entering the room from overhead.
 - 4. Extend conduits 12 inches (75 mm) above finished floor.
 - 5. Install metal conduits with grounding bushings and connect with grounding conductor to grounding system.
- E. Backboards: Install backboards with 96-inch (2440-mm) dimension vertical. Butt adjacent sheets tightly and form smooth gap-free corners and joints.

3.3 INSTALLATION OF CONDUCTORS AND CABLES

- A. Comply with NECA 1.
- B. General Requirements for Cabling:
 - 1. Comply with TIA-568-C Series of standards.
 - 2. Comply with BICSI ITSIMM, Ch. 5, "Copper Structured Cabling Systems."

3. Terminate all conductors; no cable shall contain unterminated elements. Make terminations only at indicated outlets, terminals, and cross-connect and patch panels.
4. Cables may not be spliced and shall be continuous from terminal to terminal. Do not splice cable between termination, tap, or junction points.
5. Cables serving a common system may be grouped in a common raceway. Install network cabling and control wiring and cable in separate raceway from power wiring. Do not group conductors from different systems or different voltages.
6. Secure and support cables at intervals not exceeding 30 inches (760 mm) and not more than 6 inches (150 mm) from cabinets, boxes, fittings, outlets, racks, frames, and terminals.
7. Bundle, lace, and train conductors to terminal points without exceeding manufacturer's limitations on bending radii, but not less than radii specified in BICSI ITSIMM, Ch. 5, "Copper Structured Cabling Systems." Install lacing bars and distribution spools.
8. Do not install bruised, kinked, scored, deformed, or abraded cable. Remove and discard cable if damaged during installation and replace it with new cable.
9. Cold-Weather Installation: Bring cable to room temperature before dereeling. Do not use heat lamps for heating.
10. Pulling Cable: Comply with BICSI ITSIMM, Ch. 5, "Copper Structured Cabling Systems." Monitor cable pull tensions.
11. Support: Do not allow cables to lay on removable ceiling tiles.
12. Secure: Fasten securely in place with hardware specifically designed and installed so as to not damage cables.
13. Provide strain relief.
14. Keep runs short. Allow extra length for connecting to terminals. Do not bend cables in a radius less than 10 times the cable OD. Use sleeves or grommets to protect cables from vibration at points where they pass around sharp corners and through penetrations.
15. Ground wire shall be copper, and grounding methods shall comply with IEEE C2. Demonstrate ground resistance.

C. Balanced Twisted Pair Cable Installation:

1. Comply with TIA-568-C.2.
2. Install termination hardware as specified in Section 271513 "Communications Copper Horizontal Cabling" unless otherwise indicated.
3. Do not untwist UTP cables more than 1/2 inch (12 mm) at the point of termination to maintain cable geometry.

D. Installation of Control-Circuit Conductors:

1. Install wiring in raceways. Comply with requirements specified in Section 260533 "Raceways and Boxes for Electrical Systems."

E. Open-Cable Installation:

1. Install cabling with horizontal and vertical cable guides in telecommunications spaces with terminating hardware and interconnection equipment.
2. Suspend copper cable not in a wireway or pathway a minimum of 8 inches (200 mm) above ceilings by cable supports not more than 30 inches (760 mm) apart.
3. Cable shall not be run through or on structural members or in contact with pipes, ducts, or other potentially damaging items. Do not run cables between structural members and corrugated panels.

F. Installation of Cable Routed Exposed under Raised Floors:

1. Install plenum-rated cable only.
2. Install cabling after the flooring system has been installed in raised floor areas.

3. Below each feed point, neatly coil a minimum of 72 inches (1830 mm) of cable in a coil not less than 12 inches (305 mm) in diameter.

3.4 REMOVAL OF CONDUCTORS AND CABLES

- A. Remove abandoned conductors and cables. Abandoned conductors and cables are those installed that are not terminated at equipment and are not identified with a tag for future use.

3.5 CONTROL-CIRCUIT CONDUCTORS

- A. Minimum Conductor Sizes:
 1. Class 1 remote-control and signal circuits; No 14 AWG.
 2. Class 2 low-energy, remote-control, and signal circuits; No. 16 AWG.
 3. Class 3 low-energy, remote-control, alarm, and signal circuits; No 12 AWG.

3.6 FIRESTOPPING

- A. Comply with requirements in Section 078413 "Penetration Firestopping."
- B. Comply with TIA-569-D, Annex A, "Firestopping."
- C. Comply with BICSI TDMM, "Firestopping" Chapter.

3.7 GROUNDING

- A. For data communication wiring, comply with TIA-607-B and with BICSI TDMM, "Bonding and Grounding (Earthing)" Chapter.
- B. For low-voltage control wiring and cabling, comply with requirements in Section 260526 "Grounding and Bonding for Electrical Systems."

3.8 IDENTIFICATION

- A. Comply with requirements for identification specified in Section 260553 "Identification for Electrical Systems."
- B. Identify data and communications system components, wiring, and cabling according to TIA-606-B; label printers shall use label stocks, laminating adhesives, and inks complying with UL 969.
- C. Identify each wire on each end and at each terminal with a number-coded identification tag. Each wire shall have a unique tag.

3.9 FIELD QUALITY CONTROL

- A. Perform tests and inspections with the assistance of a factory-authorized service representative.
- B. Tests and Inspections:

1. Visually inspect cable jacket materials for UL or third-party certification markings. Inspect cabling terminations to confirm color-coding for pin assignments, and inspect cabling connections to confirm compliance with TIA-568-C.1.
 2. Visually inspect cable placement, cable termination, grounding and bonding, equipment and patch cords, and labeling of all components.
- C. End-to-end cabling will be considered defective if it does not pass tests and inspections.
- D. Prepare test and inspection reports.

END OF SECTION 26 05 23

SECTION 26 0526 - GROUNDING AND BONDING FOR ELECTRICAL SYSTEMS

PART 1 - GENERAL

1.1 SUMMARY

- A. Section includes grounding and bonding systems and equipment.
- B. Section includes grounding and bonding systems and equipment, plus the following special applications:
 - 1. Underground distribution grounding.
 - 2. Ground bonding common with lightning protection system.
 - 3. Foundation steel electrodes.

1.2 ACTION SUBMITTALS

- A. Product Data: For each type of product.

1.3 INFORMATIONAL SUBMITTALS

- A. Coordination Drawings: Plans showing dimensioned as-built locations of grounding features specified in "Field Quality Control" Article.
- B. Qualification Data: For testing agency and testing agency's field supervisor.
- C. Field quality-control reports.

1.4 CLOSEOUT SUBMITTALS

- A. Operation and maintenance data.
 - 1. Plans showing as-built, dimensioned locations of system described in "Field Quality Control" Article, including the following:
 - a. Test wells.
 - b. Ground rods.
 - c. Ground rings.
 - d. Grounding arrangements and connections for separately derived systems.
 - 2. Instructions for periodic testing and inspection of grounding features at test wells, ground rings, and grounding connections for separately derived systems based on NETA MTS and NFPA 70B.
 - a. Tests shall determine if ground-resistance or impedance values remain within specified maximums, and instructions shall recommend corrective action if values do not.
 - b. Include recommended testing intervals.

1.5 QUALITY ASSURANCE

- A. Testing Agency Qualifications: Certified by NETA.

PART 2 - PRODUCTS

2.1 SYSTEM DESCRIPTION

- A. Electrical Components, Devices, and Accessories: Listed and labeled as defined in NFPA 70, by a qualified testing agency, and marked for intended location and application.
- B. Comply with UL 467 for grounding and bonding materials and equipment.

2.2 MANUFACTURERS

- A. Manufacturers: Subject to compliance with requirements, available manufacturers offering products that may be incorporated into the Work include, but are not limited to the following:
 - 1. Emerson Electric Co. (Automation Solutions - Appleton - O-Z/Gedney).
 - 2. Hubbell Incorporated (Burndy).
 - 3. ILSCO.

2.3 CONDUCTORS

- A. Insulated Conductors: Copper or tinned-copper wire or cable insulated for 600 V unless otherwise required by applicable Code or authorities having jurisdiction.
- B. Bare Copper Conductors:
 - 1. Solid Conductors: ASTM B3.
 - 2. Stranded Conductors: ASTM B8.
 - 3. Tinned Conductors: ASTM B33.
 - 4. Bonding Cable: 28 kcmil, 14 strands of No. 17 AWG conductor, 1/4 inch (6 mm) in diameter.
 - 5. Bonding Conductor: No. 4 or No. 6 AWG, stranded conductor.
 - 6. Bonding Jumper: Copper tape, braided conductors terminated with copper ferrules; 1-5/8 inches (41 mm) wide and 1/16 inch (1.6 mm) thick.
 - 7. Tinned Bonding Jumper: Tinned-copper tape, braided conductors terminated with copper ferrules; 1-5/8 inches (41 mm) wide and 1/16 inch (1.6 mm) thick.
- C. Grounding Bus: Predrilled rectangular bars of annealed copper, 1/4 by 4 inches (6.3 by 100 mm) in cross section, with 9/32-inch (7.14-mm) holes spaced 1-1/8 inches (28 mm) apart. Stand-off insulators for mounting shall comply with UL 891 for use in switchboards, 600 V and shall be Lexan or PVC, impulse tested at 5000 V.

2.4 CONNECTORS

- A. Listed and labeled by an NRTL acceptable to authorities having jurisdiction for applications in which used and for specific types, sizes, and combinations of conductors and other items connected.

- B. Welded Connectors: Exothermic-welding kits of types recommended by kit manufacturer for materials being joined and installation conditions.
- C. Bus-Bar Connectors: Mechanical type, cast silicon bronze, solderless exothermic-type wire terminals, and long-barrel, two-bolt connection to ground bus bar.
- D. Bus-Bar Connectors: Compression type, copper or copper alloy, with two wire terminals.
- E. Beam Clamps: Mechanical type, terminal, ground wire access from four directions, with dual, tin-plated or silicon bronze bolts.
- F. Cable-to-Cable Connectors: Compression type, copper or copper alloy.
- G. Cable Tray Ground Clamp: Mechanical type, zinc-plated malleable iron.
- H. Conduit Hubs: Mechanical type, terminal with threaded hub.
- I. Ground Rod Clamps: Mechanical type, copper or copper alloy, terminal with hex head bolt or socket set screw.
- J. Ground Rod Clamps: Mechanical type, copper or copper alloy, terminal with hex head bolt.
- K. Lay-in Lug Connector: Mechanical type, copper rated for direct burial terminal with set screw.
- L. Service Post Connectors: Mechanical type, bronze alloy terminal, in short- and long-stud lengths, capable of single and double conductor connections.
- M. Signal Reference Grid Clamp: Mechanical type, stamped-steel terminal with hex head screw.
- N. Straps: Solid copper, copper lugs. Rated for 600 A.
- O. Tower Ground Clamps: Mechanical type, copper or copper alloy, terminal one-piece clamp.
- P. U-Bolt Clamps: Mechanical type, copper or copper alloy, terminal listed for direct burial.
- Q. Water Pipe Clamps:
 - 1. Mechanical type, two pieces with stainless-steel bolts.
 - a. Material: Tin-plated aluminum or Die-cast zinc alloy.
 - b. Listed for direct burial.
 - 2. U-bolt type with malleable-iron clamp and copper ground connector rated for direct burial.

2.5 GROUNDING ELECTRODES

- A. Ground Rods: Copper-clad steel; 3/4 inch by 10 feet (19 mm by 3 m).
- B. Ground Plates: 1/4 inch (6 mm) thick, hot-dip galvanized.

PART 3 - EXECUTION

3.1 APPLICATIONS

- A. Conductors: Install solid conductor for No. 8 AWG and smaller, and stranded conductors for No. 6 AWG and larger unless otherwise indicated.
- B. Underground Grounding Conductors: Install bare copper conductor, No. 2/0 AWG minimum.
 - 1. Bury at least 30 inches (750 mm) below grade.
- C. Grounding Bus: Install in electrical equipment rooms, in rooms housing service equipment, and elsewhere as indicated.
 - 1. Install bus horizontally, on insulated spacers 2 inches (50 mm) minimum from wall, 6 inches (150 mm) above finished floor unless otherwise indicated.
 - 2. Where indicated on both sides of doorways, route bus up to top of door frame, across top of doorway, and down; connect to horizontal bus.
- D. Conductor Terminations and Connections:
 - 1. Pipe and Equipment Grounding Conductor Terminations: Bolted connectors.
 - 2. Underground Connections: Welded connectors except at test wells and as otherwise indicated.
 - 3. Connections to Ground Rods at Test Wells: Bolted connectors.
 - 4. Connections to Structural Steel: Welded connectors.

3.2 GROUNDING AT THE SERVICE

- A. Equipment grounding conductors and grounding electrode conductors shall be connected to the ground bus. Install a main bonding jumper between the neutral and ground buses.

3.3 GROUNDING SEPARATELY DERIVED SYSTEMS

- A. Generator: Install grounding electrode(s) at the generator location. The electrode shall be connected to the equipment grounding conductor and to the frame of the generator.

3.4 GROUNDING UNDERGROUND DISTRIBUTION SYSTEM COMPONENTS

- A. Comply with IEEE C2 grounding requirements.
- B. Grounding Manholes and Handholes: Install a driven ground rod through manhole or handhole floor, close to wall, and set rod depth so 4 inches (100 mm) will extend above finished floor. If necessary, install ground rod before manhole is placed and provide No. 1/0 AWG bare, tinned-copper conductor from ground rod into manhole through a waterproof sleeve in manhole wall. Protect ground rods passing through concrete floor with a double wrapping of pressure-sensitive insulating tape or heat-shrunk insulating sleeve from 2 inches (50 mm) above to 6 inches (150 mm) below concrete. Seal floor opening with waterproof, nonshrink grout.
- C. Grounding Connections to Manhole Components: Bond exposed-metal parts such as inserts, cable racks, pulling irons, ladders, and cable shields within each manhole or handhole, to

ground rod or grounding conductor. Make connections with No. 4 AWG minimum, stranded, hard-drawn copper bonding conductor. Train conductors level or plumb around corners and fasten to manhole walls. Connect to cable armor and cable shields according to written instructions by manufacturer of splicing and termination kits.

- D. Pad-Mounted Transformers and Switches: Install two ground rods and ground ring around the pad. Ground pad-mounted equipment and noncurrent-carrying metal items associated with substations by connecting them to underground cable and grounding electrodes. Install tinned-copper conductor not less than No. 2 AWG for ground ring and for taps to equipment grounding terminals. Bury ground ring not less than 6 inches (150 mm) from the foundation.

3.5 EQUIPMENT GROUNDING

- A. Install insulated equipment grounding conductors with all feeders and branch circuits.
- B. Install insulated equipment grounding conductors with the following items, in addition to those required by NFPA 70:
 - 1. Feeders and branch circuits.
 - 2. Lighting circuits.
 - 3. Receptacle circuits.
 - 4. Single-phase motor and appliance branch circuits.
 - 5. Three-phase motor and appliance branch circuits.
 - 6. Flexible raceway runs.
 - 7. Armored and metal-clad cable runs.
 - 8. Busway Supply Circuits: Install insulated equipment grounding conductor from grounding bus in the switchgear, switchboard, or distribution panel to equipment grounding bar terminal on busway.
 - 9. X-Ray Equipment Circuits: Install insulated equipment grounding conductor in circuits supplying x-ray equipment.
- C. Air-Duct Equipment Circuits: Install insulated equipment grounding conductor to duct-mounted electrical devices operating at 120 V and more, including air cleaners, heaters, dampers, humidifiers, and other duct electrical equipment. Bond conductor to each unit and to air duct and connected metallic piping.
- D. Water Heater, Heat-Tracing, and Antifrost Heating Cables: Install a separate insulated equipment grounding conductor to each electric water heater and heat-tracing cable. Bond conductor to heater units, piping, connected equipment, and components.
- E. Poles Supporting Outdoor Lighting Fixtures: Install grounding electrode and a separate insulated equipment grounding conductor in addition to grounding conductor installed with branch-circuit conductors.

3.6 FENCE GROUNDING

- A. Fence Grounding: Install at maximum intervals of [1500 feet (450 m)] except as follows:
 - 1. Fences within 100 Feet (30 m) of Buildings, Structures, Walkways, and Roadways: Ground at maximum intervals of [750 feet (225 m)].
 - a. Gates and Other Fence Openings: Ground fence on each side of opening.

- B. Protection at Crossings of Overhead Electrical Power Lines: Ground fence at location of crossing and at a maximum distance of 150 feet (45 m) on each side of crossing.
- C. Fences Enclosing Electrical Power Distribution Equipment: Ground as required by IEEE C2 unless otherwise indicated.

3.7 INSTALLATION

- A. Grounding Conductors: Route along shortest and straightest paths possible unless otherwise indicated or required by Code. Avoid obstructing access or placing conductors where they may be subjected to strain, impact, or damage.
- B. Ground Bonding Common with Lightning Protection System: Comply with NFPA 780 and UL 96 when interconnecting with lightning protection system. Bond electrical power system ground directly to lightning protection system grounding conductor at closest point to electrical service grounding electrode. Use bonding conductor sized same as system grounding electrode conductor, and install in conduit.
- C. Ground Rods: Drive rods until tops are 2 inches (50 mm) below finished floor or final grade unless otherwise indicated.
 - 1. Interconnect ground rods with grounding electrode conductor below grade and as otherwise indicated. Make connections without exposing steel or damaging coating if any.
- D. Bonding Straps and Jumpers: Install in locations accessible for inspection and maintenance except where routed through short lengths of conduit.
 - 1. Bonding to Structure: Bond straps directly to basic structure, taking care not to penetrate any adjacent parts.
 - 2. Bonding to Equipment Mounted on Vibration Isolation Hangers and Supports: Install bonding so vibration is not transmitted to rigidly mounted equipment.
 - 3. Use exothermic-welded connectors for outdoor locations; if a disconnect-type connection is required, use a bolted clamp.
- E. Grounding and Bonding for Piping:
 - 1. Metal Water Service Pipe: Install insulated copper grounding conductors, in conduit, from building's main service equipment, or grounding bus, to main metal water service entrances to building. Connect grounding conductors to main metal water service pipes; use a bolted clamp connector or bolt a lug-type connector to a pipe flange by using one of the lug bolts of the flange. Where a dielectric main water fitting is installed, connect grounding conductor on street side of fitting. Bond metal grounding conductor conduit or sleeve to conductor at each end.
 - 2. Water Meter Piping: Use braided-type bonding jumpers to electrically bypass water meters. Connect to pipe with a bolted connector.
 - 3. Bond each aboveground portion of gas piping system downstream from equipment shutoff valve.

3.8 FIELD QUALITY CONTROL

- A. Perform tests and inspections with the assistance of a factory-authorized service representative.
- B. Tests and Inspections:

1. After installing grounding system but before permanent electrical circuits have been energized, test for compliance with requirements.
 2. Inspect physical and mechanical condition. Verify tightness of accessible, bolted, electrical connections with a calibrated torque wrench according to manufacturer's written instructions.
 3. Test completed grounding system at each location where a maximum ground-resistance level is specified, at service disconnect enclosure grounding terminal, at ground test wells, and at individual ground rods. Make tests at ground rods before any conductors are connected.
 - a. Measure ground resistance no fewer than two full days after last trace of precipitation and without soil being moistened by any means other than natural drainage or seepage and without chemical treatment or other artificial means of reducing natural ground resistance.
 - b. Perform tests by fall-of-potential method according to IEEE 81.
 4. Prepare dimensioned Drawings locating each test well, ground rod and ground-rod assembly, and other grounding electrodes. Identify each by letter in alphabetical order, and key to the record of tests and observations. Include the number of rods driven and their depth at each location, and include observations of weather and other phenomena that may affect test results. Describe measures taken to improve test results.
- C. Grounding system will be considered defective if it does not pass tests and inspections.
- D. Prepare test and inspection reports.
- E. Report measured ground resistances that exceed the following values:
1. Power and Lighting Equipment or System with Capacity of 500 kVA and Less: 10 ohms.
 2. Power and Lighting Equipment or System with Capacity of 500 to 1000 kVA: 5 ohms.
 3. Power and Lighting Equipment or System with Capacity More Than 1000 kVA: 3 ohms.
 4. Power Distribution Units or Panelboards Serving Electronic Equipment: 3 ohm(s).
 5. Substations and Pad-Mounted Equipment: 5 ohms.
 6. Manhole Grounds: 10 ohms.
- F. Excessive Ground Resistance: If resistance to ground exceeds specified values, notify Architect promptly and include recommendations to reduce ground resistance.

END OF SECTION 26 05 26

SECTION 26 0529 - HANGERS AND SUPPORTS FOR ELECTRICAL SYSTEMS

PART 1 - GENERAL

1.1 SUMMARY

A. Section Includes:

1. Steel slotted support systems.
2. Conduit and cable support devices.
3. Support for conductors in vertical conduit.
4. Structural steel for fabricated supports and restraints.
5. Mounting, anchoring, and attachment components, including powder-actuated fasteners, mechanical expansion anchors, concrete inserts, clamps, through bolts, toggle bolts, and hanger rods.
6. Fabricated metal equipment support assemblies.

B. Related Requirements:

1. Section 260548.16 "Seismic Controls for Electrical Systems" for products and installation requirements necessary for compliance with seismic criteria.

1.2 ACTION SUBMITTALS

A. Product Data: For each type of product.

B. Shop Drawings: For fabrication and installation details for electrical hangers and support systems.

1. Hangers. Include product data for components.
2. Slotted support systems.
3. Equipment supports.
4. Vibration Isolation Base Details: Detail fabrication including anchorages and attachments to structure and to supported equipment. Include adjustable motor bases, rails, and frames for equipment mounting.

C. Delegated-Design Submittal: For hangers and supports for electrical systems.

1. Include design calculations and details of hangers.
2. Include design calculations for seismic restraints.

1.3 INFORMATIONAL SUBMITTALS

A. Coordination Drawings: Reflected ceiling plan(s) and other details, drawn to scale, and coordinated with each other, using input from installers of the items involved.

B. Seismic Qualification Data: Certificates, for hangers and supports for electrical equipment and systems, accessories, and components, from manufacturer.

C. Welding certificates.

1.4 QUALITY ASSURANCE

- A. Welding Qualifications: Qualify procedures and personnel according to the following:
 - 1. AWS D1.1/D1.1M.
 - 2. AWS D1.2/D1.2M.

PART 2 - PRODUCTS

2.1 PERFORMANCE REQUIREMENTS

- A. Delegated Design: Engage a qualified professional engineer, as defined in Section 014000 "Quality Requirements," to design hanger and support system.
- B. Seismic Performance: Hangers and supports shall withstand the effects of earthquake motions determined according to ASCE/SEI 7.
 - 1. The term "withstand" means "the supported equipment and systems will remain in place without separation of any parts when subjected to the seismic forces specified and the supported equipment and systems will be fully operational after the seismic event."
 - 2. Component Importance Factor: 1.5.
- C. Surface-Burning Characteristics: Comply with ASTM E84; testing by a qualified testing agency. Identify products with appropriate markings of applicable testing agency.
 - 1. Flame Rating: Class 1.
 - 2. Self-extinguishing according to ASTM D635.

2.2 SUPPORT, ANCHORAGE, AND ATTACHMENT COMPONENTS

- A. Steel Slotted Support Systems: Preformed steel channels and angles with minimum 13/32-inch- (10-mm-) diameter holes at a maximum of 8 inches (200 mm) o.c. in at least one surface.
 - 1. Manufacturers: Subject to compliance with requirements, available manufacturers offering products that may be incorporated into the Work include, but are not limited to the following:
 - a. Atkore International (Unistrut).
 - b. Eaton (B-line).
 - c. nVent (CADDY).
 - 2. Standard: Comply with MFMA-4 factory-fabricated components for field assembly.
 - 3. Material for Channel, Fittings, and Accessories: Galvanized steel, Stainless steel Type 304, or Stainless steel Type 316.
 - 4. Channel Width: 1-5/8 inches (41.25 mm).
 - 5. Metallic Coatings: Hot-dip galvanized after fabrication and applied according to MFMA-4.
 - 6. Nonmetallic Coatings: Manufacturer's standard PVC, polyurethane, or polyester coating applied according to MFMA-4.
 - 7. Painted Coatings: Manufacturer's standard painted coating applied according to MFMA-4.
 - 8. Protect finishes on exposed surfaces from damage by applying a strippable, temporary protective covering before shipping.

- B. Conduit and Cable Support Devices: Steel and malleable-iron hangers, clamps, and associated fittings, designed for types and sizes of raceway or cable to be supported.
- C. Support for Conductors in Vertical Conduit: Factory-fabricated assembly consisting of threaded body and insulating wedging plug or plugs for nonarmored electrical conductors or cables in riser conduits. Plugs shall have number, size, and shape of conductor gripping pieces as required to suit individual conductors or cables supported. Body shall be made of malleable iron.
- D. Structural Steel for Fabricated Supports and Restraints: ASTM A36/A36M steel plates, shapes, and bars; black and galvanized.
- E. Mounting, Anchoring, and Attachment Components: Items for fastening electrical items or their supports to building surfaces include the following:
 - 1. Powder-Actuated Fasteners: Threaded-steel stud, for use in hardened portland cement concrete, steel, or wood, with tension, shear, and pullout capacities appropriate for supported loads and building materials where used.
 - a. Manufacturers: Subject to compliance with requirements, available manufacturers offering products that may be incorporated into the Work include, but are not limited to the following:
 - 1) Hilti, Inc.
 - 2) ITW Ramset/Red Head; Illinois Tool Works, Inc.
 - 2. Mechanical-Expansion Anchors: Insert-wedge-type, **zinc-coated or stainless** steel, for use in hardened portland cement concrete, with tension, shear, and pullout capacities appropriate for supported loads and building materials where used.
 - a. Manufacturers: Subject to compliance with requirements, available manufacturers offering products that may be incorporated into the Work include, but are not limited to the following:
 - 1) Eaton (B-line).
 - 2) Hilti, Inc.
 - 3) ITW Ramset/Red Head; Illinois Tool Works, Inc.
 - 3. Concrete Inserts: Steel or malleable-iron, slotted support system units are similar to MSS Type 18 units and comply with MFMA-4 or MSS SP-58.
 - 4. Clamps for Attachment to Steel Structural Elements: MSS SP-58 units are suitable for attached structural element.
 - 5. Through Bolts: Structural type, hex head, and high strength. Comply with ASTM F3125/F3125M, Grade A325 (Grade A325M).
 - 6. Toggle Bolts: All-steel springhead type.
 - 7. Hanger Rods: Threaded steel.

2.3 FABRICATED METAL EQUIPMENT SUPPORT ASSEMBLIES

- A. Description: Welded or bolted structural-steel shapes, shop or field fabricated to fit dimensions of supported equipment.
- B. Materials: Comply with requirements in Section 055000 "Metal Fabrications" for steel shapes and plates.

PART 3 - EXECUTION

3.1 APPLICATION

- A. Comply with the following standards for application and installation requirements of hangers and supports, except where requirements on Drawings or in this Section are stricter:
 - 1. NECA 1.
 - 2. NECA 101
 - 3. NECA 102.
 - 4. NECA 105.
 - 5. NECA 111.
- B. Comply with requirements in Section 078413 "Penetration Firestopping" for firestopping materials and installation for penetrations through fire-rated walls, ceilings, and assemblies.
- C. Comply with requirements for raceways and boxes specified in Section 260533 "Raceways and Boxes for Electrical Systems."
- D. Maximum Support Spacing and Minimum Hanger Rod Size for Raceways: Space supports for EMT, IMC, and RMC as required by scheduled in NECA 1, where its Table 1 lists maximum spacings that are less than those stated in NFPA 70. Minimum rod size shall be 1/4 inch (6 mm) in diameter.
- E. Multiple Raceways or Cables: Install trapeze-type supports fabricated with steel slotted support system, sized so capacity can be increased by at least 25 percent in future without exceeding specified design load limits.
 - 1. Secure raceways and cables to these supports with single-bolt conduit clamps using spring friction action for retention in support channel.
- F. Spring-steel clamps designed for supporting single conduits without bolts may be used for 1-1/2-inch (38-mm) and smaller raceways serving branch circuits and communication systems above suspended ceilings, and for fastening raceways to trapeze supports.

3.2 SUPPORT INSTALLATION

- A. Comply with NECA 1 and NECA 101 for installation requirements except as specified in this article.
- B. Raceway Support Methods: In addition to methods described in NECA 1, EMT IMC and RMC may be supported by openings through structure members, according to NFPA 70.
- C. Strength of Support Assemblies: Where not indicated, select sizes of components so strength will be adequate to carry present and future static loads within specified loading limits. Minimum static design load used for strength determination shall be weight of supported components plus 200 lb (90 kg).
- D. Mounting and Anchorage of Surface-Mounted Equipment and Components: Anchor and fasten electrical items and their supports to building structural elements by the following methods unless otherwise indicated by code:
 - 1. To Wood: Fasten with lag screws or through bolts.

2. To New Concrete: Bolt to concrete inserts.
 3. To Masonry: Approved toggle-type bolts on hollow masonry units and expansion anchor fasteners on solid masonry units.
 4. To Existing Concrete: Expansion anchor fasteners.
 5. Instead of expansion anchors, powder-actuated driven threaded studs provided with lock washers and nuts may be used in existing standard-weight concrete 4 inches (100 mm) thick or greater. Do not use for anchorage to lightweight-aggregate concrete or for slabs less than 4 inches (100 mm) thick.
 6. To Steel: Beam clamps (MSS SP-58, Type 19, 21, 23, 25, or 27), complying with MSS SP-69.
 7. To Light Steel: Sheet metal screws.
 8. Items Mounted on Hollow Walls and Nonstructural Building Surfaces: Mount cabinets, panelboards, disconnect switches, control enclosures, pull and junction boxes, transformers, and other devices on slotted-channel racks attached to substrate by means that comply with seismic-restraint strength and anchorage requirements.
- E. Drill holes for expansion anchors in concrete at locations and to depths that avoid the need for reinforcing bars.

3.3 INSTALLATION OF FABRICATED METAL SUPPORTS

- A. Comply with installation requirements in Section 055000 "Metal Fabrications" for site-fabricated metal supports.
- B. Cut, fit, and place miscellaneous metal supports accurately in location, alignment, and elevation to support and anchor electrical materials and equipment.
- C. Field Welding: Comply with AWS D1.1/D1.1M.

END OF SECTION 26 05 29

SECTION 26 0533 - RACEWAYS AND BOXES FOR ELECTRICAL SYSTEMS

PART 1 - GENERAL

1.1 SUMMARY

A. Section Includes:

1. Metal conduits and fittings.
2. Nonmetallic conduits and fittings.
3. Metal wireways and auxiliary gutters.
4. Nonmetal wireways and auxiliary gutters.
5. Surface raceways.
6. Boxes, enclosures, and cabinets.
7. Handholes and boxes for exterior underground cabling.

B. Related Requirements:

1. Section 078413 "Penetration Firestopping" for firestopping at conduit and box entrances.
2. Section 260543 "Underground Ducts and Raceways for Electrical Systems" for exterior ductbanks, manholes, and underground utility construction.
3. Section 270528 "Pathways for Communications Systems" for conduits, wireways, surface pathways, innerduct, boxes, faceplate adapters, enclosures, cabinets, and handholes serving communications systems.

1.2 ACTION SUBMITTALS

A. Product Data: For each type of product.

B. Shop Drawings: For custom enclosures and cabinets. Include plans, elevations, sections, and attachment details.

1.3 INFORMATIONAL SUBMITTALS

A. Coordination Drawings: Conduit routing plans, drawn to scale, on which the following items are shown and coordinated with each other, using input from installers of items involved:

1. Structural members in paths of conduit groups with common supports.
2. HVAC and plumbing items and architectural features in paths of conduit groups with common supports.

B. Seismic Qualification Data: Certificates, for enclosures, cabinets, and conduit racks and their mounting provisions, including those for internal components, from manufacturer.

PART 2 - PRODUCTS

2.1 METAL CONDUITS AND FITTINGS

A. Metal Conduit:

1. Manufacturers: Subject to compliance with requirements, available manufacturers offering products that may be incorporated into the Work include, but are not limited to the following:
 - a. ABB (Electrification Products Division).
 - b. Atkore International (Allied Tube & Conduit).
 - c. Emerson Electric Co. (Automation Solutions - Appleton - O-Z/Gedney).
2. Listing and Labeling: Metal conduits, tubing, and fittings shall be listed and labeled as defined in NFPA 70, by a qualified testing agency, and marked for intended location and application.
3. GRC: Comply with ANSI C80.1 and UL 6.
4. ARC: Comply with ANSI C80.5 and UL 6A.
5. IMC: Comply with ANSI C80.6 and UL 1242.
6. PVC-Coated Steel Conduit: PVC-coated rigid steel conduit.
 - a. Comply with NEMA RN 1.
 - b. Coating Thickness: 0.040 inch (1 mm), minimum.
7. EMT: Comply with ANSI C80.3 and UL 797.
8. FMC: Comply with UL 1; zinc-coated steel or aluminum.
9. LFMC: Flexible steel conduit with PVC jacket and complying with UL 360.

B. Metal Fittings: Comply with NEMA FB 1 and UL 514B.

1. Listing and Labeling: Listed and labeled as defined in NFPA 70, by a qualified testing agency, and marked for intended location and application.
2. Fittings, General: Listed and labeled for type of conduit, location, and use.
3. Conduit Fittings for Hazardous (Classified) Locations: Comply with UL 1203 and NFPA 70.
4. Fittings for EMT:
 - a. Material: Steel.
 - b. Type: compression.
5. Expansion Fittings: PVC or steel to match conduit type, complying with UL 651, rated for environmental conditions where installed, and including flexible external bonding jumper.
6. Coating for Fittings for PVC-Coated Conduit: Minimum thickness of 0.040 inch (1 mm), with overlapping sleeves protecting threaded joints.

C. Joint Compound for IMC, GRC, or ARC: Approved, as defined in NFPA 70, by authorities having jurisdiction for use in conduit assemblies, and compounded for use to lubricate and protect threaded conduit joints from corrosion and to enhance their conductivity.

2.2 NONMETALLIC CONDUITS AND FITTINGS

A. Nonmetallic Conduit:

1. Manufacturers: Subject to compliance with requirements, available manufacturers offering products that may be incorporated into the Work include, but are not limited to the following:
 - a. Cantex Inc.
 - b. Champion Fiberglass, Inc.
 - c. Hubbell Incorporated (Raco Taymac Bell).
 - d. Kraloy Fittings.
 - e. Lamson & Sessions.

- B. Listing and Labeling: Listed and labeled as defined in NFPA 70, by a qualified testing agency, and marked for intended location and application.
 1. ENT: Comply with NEMA TC 13 and UL 1653.
 2. RNC: Type EPC-40-PVC, complying with NEMA TC 2 and UL 651 unless otherwise indicated.
 3. LFNC: Comply with UL 1660.

- C. Nonmetallic Fittings:
 1. Manufacturers: Subject to compliance with requirements, available manufacturers offering products that may be incorporated into the Work include, but are not limited to the following:
 - a. Cantex Inc.
 - b. Champion Fiberglass, Inc.
 - c. Hubbell Incorporated (Raco Taymac Bell).
 - d. Kraloy Fittings.
 - e. Lamson & Sessions.

 2. Fittings, General: Listed and labeled for type of conduit, location, and use.
 3. Fittings for ENT and RNC: Comply with NEMA TC 3; match to conduit or tubing type and material.
 4. Fittings for LFNC: Comply with UL 514B.
 5. Solvents and Adhesives: As recommended by conduit manufacturer.

2.3 METAL WIREWAYS AND AUXILIARY GUTTERS

- A. Manufacturers: Subject to compliance with requirements, available manufacturers offering products that may be incorporated into the Work include, but are not limited to the following:
 1. ABB (Electrification Products Division).
 2. Eaton (B-line).
 3. Hubbell Incorporated (Wiegmann).
 4. nVent (Hoffman).
 5. Schneider Electric USA (Square D).

- B. Description: Sheet metal, complying with UL 870 and NEMA 250, Type 1, Type 3R, Type 4X, or Type 12 as required by installation use/location unless otherwise indicated, and sized according to NFPA 70.
 1. Metal wireways installed outdoors shall be listed and labeled as defined in NFPA 70, by a qualified testing agency, and marked for intended location and application.

- C. Fittings and Accessories: Include covers, couplings, offsets, elbows, expansion joints, adapters, hold-down straps, end caps, and other fittings to match and mate with wireways as required for complete system.

2.4 NONMETALLIC WIREWAYS AND AUXILIARY GUTTERS

- A. Manufacturers: Subject to compliance with requirements, available manufacturers offering products that may be incorporated into the Work include, but are not limited to the following:
 - 1. ABB (Electrification Products Division).
 - 2. Eaton (B-line).
 - 3. Hubbell Incorporated (Wiegmann).
 - 4. nVent (Hoffman).
 - 5. Schneider Electric USA (Square D).
- B. Listing and Labeling: Nonmetallic wireways and auxiliary gutters shall be listed and labeled as defined in NFPA 70, by a qualified testing agency, and marked for intended location and application.
- C. Description: PVC, extruded and fabricated to required size and shape, and having snap-on cover, mechanically coupled connections, and plastic fasteners.
- D. Fittings and Accessories: Couplings, offsets, elbows, expansion joints, adapters, hold-down straps, end caps, and other fittings shall match and mate with wireways as required for complete system.
- E. Solvents and Adhesives: As recommended by conduit manufacturer.

2.5 BOXES, ENCLOSURES, AND CABINETS

- A. Manufacturers: Subject to compliance with requirements, available manufacturers offering products that may be incorporated into the Work include, but are not limited to the following:
 - 1. ABB (Electrification Products Division).
 - 2. Eaton (Crouse-Hinds).
 - 3. Emerson Electric Co. (Automation Solutions - Appleton - EGS).
 - 4. Emerson Electric Co. (Automation Solutions - Appleton - O-Z/Gedney).
 - 5. Erickson Electrical Equipment Company.
 - 6. Hubbell Incorporated (Raco Taymac Bell).
- B. General Requirements for Boxes, Enclosures, and Cabinets: Boxes, enclosures, and cabinets installed in wet locations shall be listed for use in wet locations.
- C. Sheet Metal Outlet and Device Boxes: Comply with NEMA OS 1 and UL 514A.
- D. Cast-Metal Outlet and Device Boxes: Comply with NEMA FB 1, aluminum, Type FD, with gasketed cover.
- E. Nonmetallic Outlet and Device Boxes: Comply with NEMA OS 2 and UL 514C.
- F. Metal Floor Boxes:
 - 1. Material: sheet metal.

2. Type: Fully adjustable.
 3. Shape: Rectangular.
 4. Covers: Flush in-use.
 5. Listing and Labeling: Metal floor boxes shall be listed and labeled as defined in NFPA 70, by a qualified testing agency, and marked for intended location and application.
- G. Nonmetallic Floor Boxes: Nonadjustable, round.
1. Listing and Labeling: Nonmetallic floor boxes shall be listed and labeled as defined in NFPA 70, by a qualified testing agency, and marked for intended location and application.
- H. Luminaire Outlet Boxes: Nonadjustable, designed for attachment of luminaire weighing 50 lb (23 kg). Outlet boxes designed for attachment of luminaires weighing more than 50 lb (23 kg) shall be listed and marked for the maximum allowable weight.
- I. Paddle Fan Outlet Boxes: Nonadjustable, designed for attachment of paddle fan weighing 70 lb (32 kg).
1. Listing and labeling: Paddle fan outlet boxes shall be listed and labeled as defined in NFPA 70, by a qualified testing agency, and marked for intended location and application.
- J. Small Sheet Metal Pull and Junction Boxes: NEMA OS 1.
- K. Cast-Metal Access, Pull, and Junction Boxes: Comply with NEMA FB 1 and UL 1773, cast aluminum with gasketed cover.
- L. Box extensions used to accommodate new building finishes shall be of same material as recessed box.
- M. Device Box Dimensions: 4 inches square by 2-1/8 inches deep (100 mm square by 60 mm deep), 4 inches by 2-1/8 inches by 2-1/8 inches deep (100 mm by 60 mm by 60 mm deep).
- N. Gangable boxes are prohibited.
- O. Hinged-Cover Enclosures: Comply with UL 50 and NEMA 250, Type 1, Type 3R, Type 4X, or Type 12 as required by installation use/location, with continuous-hinge cover with flush latch unless otherwise indicated.
1. Metal Enclosures: Steel, finished inside and out with manufacturer's standard enamel.
 2. Nonmetallic Enclosures: Plastic.
 3. Interior Panels: Steel; all sides finished with manufacturer's standard enamel.
- P. Cabinets:
1. NEMA 250, Type 1, Type 3R, Type 4X, or Type 12 as required by installation use/location, galvanized-steel box with removable interior panel and removable front, finished inside and out with manufacturer's standard enamel.
 2. Hinged door in front cover with flush latch and concealed hinge.
 3. Key latch to match panelboards.
 4. Metal barriers to separate wiring of different systems and voltage.
 5. Accessory feet where required for freestanding equipment.
 6. Nonmetallic cabinets shall be listed and labeled as defined in NFPA 70, by a qualified testing agency, and marked for intended location and application.

2.6 HANDHOLES AND BOXES FOR EXTERIOR UNDERGROUND WIRING

A. General Requirements for Handholes and Boxes:

1. Boxes and handholes for use in underground systems shall be designed and identified as defined in NFPA 70, for intended location and application.
2. Boxes installed in wet areas shall be listed and labeled as defined in NFPA 70, by a qualified testing agency, and marked for intended location and application.

B. Polymer-Concrete Handholes and Boxes with Polymer-Concrete Cover: Molded of sand and aggregate, bound together with polymer resin, and reinforced with steel, fiberglass, or a combination of the two.

1. Manufacturers: Subject to compliance with requirements, available manufacturers offering products that may be incorporated into the Work include, but are not limited to the following:
 - a. Armorcast Products Company.
 - b. Hubbell Incorporated (Quazite).
2. Standard: Comply with SCTE 77.
3. Configuration: Designed for flush burial with open bottom unless otherwise indicated.
4. Cover: Weatherproof, secured by tamper-resistant locking devices and having structural load rating consistent with enclosure and handhole location.
5. Cover Finish: Nonskid finish shall have a minimum coefficient of friction of 0.50.
6. Cover Legend: Molded lettering, "ELECTRIC".
7. Conduit Entrance Provisions: Conduit-terminating fittings shall mate with entering ducts for secure, fixed installation in enclosure wall.

C. Fiberglass Handholes and Boxes: Molded of fiberglass-reinforced polyester resin, with frame and covers of polymer concrete.

1. Manufacturers: Subject to compliance with requirements, available manufacturers offering products that may be incorporated into the Work include, but are not limited to the following:
 - a. Armorcast Products Company.
 - b. Hubbell Incorporated (Quazite).
2. Standard: Comply with SCTE 77.
3. Configuration: Designed for flush burial with open bottom unless otherwise indicated.
4. Cover: Weatherproof, secured by tamper-resistant locking devices and having structural load rating consistent with enclosure and handhole location.
5. Cover Finish: Nonskid finish shall have a minimum coefficient of friction of 0.50.
6. Cover Legend: Molded lettering, "ELECTRIC".
7. Conduit Entrance Provisions: Conduit-terminating fittings shall mate with entering ducts for secure, fixed installation in enclosure wall.

PART 3 - EXECUTION

3.1 RACEWAY APPLICATION

- A. Outdoors: Apply raceway products as specified below unless otherwise indicated:

1. Exposed Conduit: GRC.
2. Concealed Conduit, Aboveground: GRC, IMC, or EMT.
3. Underground Conduit: RNC, Type EPC-40-PVC, direct buried. Provide long-radius GRC elbows for all underground bends.
4. Connection to Vibrating Equipment (Including Transformers and Hydraulic, Pneumatic, Electric Solenoid, or Motor-Driven Equipment): LFMC.
5. Boxes and Enclosures, Aboveground: NEMA 250, Type 3R or Type 4X.

B. Indoors: Apply raceway products as specified below unless otherwise indicated.

1. Exposed, Not Subject to Physical Damage: EMT.
2. Exposed, Not Subject to Severe Physical Damage: IMC.
3. Exposed and Subject to Severe Physical Damage: GRC. Raceway locations include the following:
 - a. Loading dock.
 - b. Corridors used for traffic of mechanized carts, forklifts, and pallet-handling units.
 - c. Mechanical rooms.
 - d. Gymnasiums.
4. Concealed in Ceilings and Interior Walls and Partitions: EMT.
5. Connection to Vibrating Equipment (Including Transformers and Hydraulic, Pneumatic, Electric Solenoid, or Motor-Driven Equipment): FMC, except use LFMC in damp or wet locations.
6. Damp or Wet Locations: GRC or IMC.
7. Boxes and Enclosures: NEMA 250, Type 1, except use NEMA 250, Type 4X stainless steel in institutional and commercial kitchens and damp or wet locations.

C. Minimum Raceway Size: 3/4-inch (21-mm) trade size.

D. Raceway Fittings: Compatible with raceways and suitable for use and location.

1. Rigid and Intermediate Steel Conduit: Use threaded rigid steel conduit fittings unless otherwise indicated. Comply with NEMA FB 2.10.
2. PVC Externally Coated, Rigid Steel Conduits: Use only fittings listed for use with this type of conduit. Patch and seal all joints, nicks, and scrapes in PVC coating after installing conduits and fittings. Use sealant recommended by fitting manufacturer and apply in thickness and number of coats recommended by manufacturer.
3. EMT: Use compression, steel fittings. Comply with NEMA FB 2.10.
4. Flexible Conduit: Use only fittings listed for use with flexible conduit. Comply with NEMA FB 2.20.

E. Do not install aluminum conduits, boxes, or fittings in contact with concrete or earth.

F. Install surface raceways only where indicated on Drawings.

G. Do not install nonmetallic conduit where ambient temperature exceeds 120 deg F (49 deg C).

3.2 INSTALLATION

A. Comply with requirements in Section 260529 "Hangers and Supports for Electrical Systems" for hangers and supports.

- B. Comply with NECA 1 and NECA 101 for installation requirements except where requirements on Drawings or in this article are stricter. Comply with NECA 102 for aluminum conduits. Comply with NFPA 70 limitations for types of raceways allowed in specific occupancies and number of floors.
- C. Do not install raceways or electrical items on any "explosion-relief" walls or rotating equipment.
- D. Do not fasten conduits onto the bottom side of a metal deck roof.
- E. Keep raceways at least 6 inches (150 mm) away from parallel runs of flues and steam or hot-water pipes. Install horizontal raceway runs above water and steam piping.
- F. Comply with requirements in Section 260529 "Hangers and Supports for Electrical Systems" for hangers and supports.
- G. Arrange stub-ups so curved portions of bends are not visible above finished slab.
- H. Install no more than the equivalent of three 90-degree bends in any conduit run except for control wiring conduits, for which fewer bends are allowed. Support within 12 inches (300 mm) of changes in direction.
- I. Make bends in raceway using large-radius preformed ells. Field bending shall be according to NFPA 70 minimum radii requirements. Use only equipment specifically designed for material and size involved.
- J. Conceal conduit and EMT within finished walls, ceilings, and floors unless otherwise indicated. Install conduits parallel or perpendicular to building lines.
- K. Support conduit within 12 inches (300 mm) of enclosures to which attached.
- L. Raceways Embedded in Slabs:
 - 1. Run conduit larger than 1-inch (27-mm) trade size, parallel or at right angles to main reinforcement. Where at right angles to reinforcement, place conduit close to slab support. Secure raceways to reinforcement at maximum 10-foot (3-m) intervals.
 - 2. Arrange raceways to cross building expansion joints at right angles with expansion fittings.
 - 3. Arrange raceways to keep a minimum of 2 inches (50 mm) of concrete cover in all directions.
 - 4. Do not embed threadless fittings in concrete unless specifically approved by Architect for each specific location.
 - 5. Change from ENT to GRC or IMC before rising above floor.
- M. Stub-ups to Above Recessed Ceilings:
 - 1. Use EMT, IMC, or RMC for raceways.
 - 2. Use a conduit bushing or insulated fitting to terminate stub-ups not terminated in hubs or in an enclosure.
- N. Threaded Conduit Joints, Exposed to Wet, Damp, Corrosive, or Outdoor Conditions: Apply listed compound to threads of raceway and fittings before making up joints. Follow compound manufacturer's written instructions.
- O. Coat field-cut threads on PVC-coated raceway with a corrosion-preventing conductive compound prior to assembly.

- P. Raceway Terminations at Locations Subject to Moisture or Vibration: Use insulating bushings to protect conductors including conductors smaller than No. 4 AWG.
- Q. Terminate threaded conduits into threaded hubs or with locknuts on inside and outside of boxes or cabinets. Install bushings on conduits up to 1-1/4-inch (35-mm) trade size and insulated throat metal bushings on 1-1/2-inch (41-mm) trade size and larger conduits terminated with locknuts. Install insulated throat metal grounding bushings on service conduits.
- R. Install pull wires in empty raceways. Use polypropylene or monofilament plastic line with not less than 200-lb (90-kg) tensile strength. Leave at least 12 inches (300 mm) of slack at each end of pull wire. Cap underground raceways designated as spare above grade alongside raceways in use.
- S. Surface Raceways:
1. Install surface raceway with a minimum 2-inch (50-mm) radius control at bend points.
 2. Secure surface raceway with screws or other anchor-type devices at intervals not exceeding 48 inches (1200 mm) and with no less than two supports per straight raceway section. Support surface raceway according to manufacturer's written instructions. Tape and glue are not acceptable support methods.
- T. Install raceway sealing fittings at accessible locations according to NFPA 70 and fill them with listed sealing compound. For concealed raceways, install each fitting in a flush steel box with a blank cover plate having a finish similar to that of adjacent plates or surfaces.
- U. Install devices to seal raceway interiors at accessible locations. Locate seals so no fittings or boxes are between the seal and the following changes of environments. Seal the interior of all raceways at the following points:
1. Where conduits pass from warm to cold locations, such as boundaries of refrigerated spaces.
 2. Where an underground service raceway enters a building or structure.
 3. Conduit extending from interior to exterior of building.
 4. Conduit extending into pressurized duct and equipment.
 5. Conduit extending into pressurized zones that are automatically controlled to maintain different pressure set points.
 6. Where otherwise required by NFPA 70.
- V. Expansion-Joint Fittings:
1. Install in each run of aboveground RNC that is located where environmental temperature change may exceed 30 deg F (17 deg C) and that has straight-run length that exceeds 25 feet (7.6 m).
 2. Install type and quantity of fittings that accommodate temperature change listed for each of the following locations:
 - a. Outdoor Locations Not Exposed to Direct Sunlight: 125 deg F (70 deg C) temperature change.
 - b. Outdoor Locations Exposed to Direct Sunlight: 155 deg F (86 deg C) temperature change.
 - c. Indoor Spaces Connected with Outdoors without Physical Separation: 125 deg F (70 deg C) temperature change.
 - d. Attics: 135 deg F (75 deg C) temperature change.

3. Install fitting(s) that provide expansion and contraction for at least 0.00041 inch per foot of length of straight run per degree F (0.06 mm per meter of length of straight run per degree C) of temperature change for PVC conduits.
 4. Install expansion fittings at all locations where conduits cross building or structure expansion joints.
 5. Install each expansion-joint fitting with position, mounting, and piston setting selected according to manufacturer's written instructions for conditions at specific location at time of installation. Install conduit supports to allow for expansion movement.
- W. Flexible Conduit Connections: Comply with NEMA RV 3. Use a maximum of 72 inches (1830 mm) of flexible conduit for recessed and semirecessed luminaires, equipment subject to vibration, noise transmission, or movement; and for transformers and motors.
1. Use LFMC in damp or wet locations subject to severe physical damage.
 2. Use LFMC or LFNC in damp or wet locations not subject to severe physical damage.
- X. Mount boxes at heights indicated on Drawings. If mounting heights of boxes are not individually indicated, give priority to ADA requirements. Install boxes with height measured to center of box unless otherwise indicated.
- Y. Recessed Boxes in Masonry Walls: Saw-cut opening for box in center of cell of masonry block, and install box flush with surface of wall. Prepare block surfaces to provide a flat surface for a raintight connection between the box and cover plate or the supported equipment and box.
- Z. Horizontally separate boxes mounted on opposite sides of walls so they are not in the same vertical channel.
- AA. Locate boxes so that cover or plate will not span different building finishes.
- BB. Support boxes of three gangs or more from more than one side by spanning two framing members or mounting on brackets specifically designed for the purpose.
- CC. Fasten junction and pull boxes to or support from building structure. Do not support boxes by conduits.
- DD. Set metal floor boxes level and flush with finished floor surface.
- EE. Set nonmetallic floor boxes level. Trim after installation to fit flush with finished floor surface.

3.3 INSTALLATION OF UNDERGROUND CONDUIT

- A. Direct-Buried Conduit:
1. Excavate trench bottom to provide firm and uniform support for conduit. Prepare trench bottom as specified in Section 312000 "Earth Moving" for pipe less than 6 inches (150 mm) in nominal diameter.
 2. Install backfill as specified in Section 312000 "Earth Moving."
 3. After installing conduit, backfill and compact. Start at tie-in point, and work toward end of conduit run, leaving conduit at end of run free to move with expansion and contraction as temperature changes during this process. Firmly hand tamp backfill around conduit to provide maximum supporting strength. After placing controlled backfill to within 12 inches (300 mm) of finished grade, make final conduit connection at end of run and complete backfilling with normal compaction as specified in Section 312000 "Earth Moving."

4. Install manufactured duct elbows for stub-up at poles and equipment and at building entrances through floor unless otherwise indicated. Encase elbows for stub-up ducts throughout length of elbow.
5. Install manufactured rigid steel conduit elbows for stub-ups at poles and equipment and at building entrances through floor.
 - a. Couple steel conduits to ducts with adapters designed for this purpose, and encase coupling with 3 inches (75 mm) of concrete for a minimum of 12 inches (300 mm) on each side of the coupling.
 - b. For stub-ups at equipment mounted on outdoor concrete bases and where conduits penetrate building foundations, extend steel conduit horizontally a minimum of 60 inches (1500 mm) from edge of foundation or equipment base. Install insulated grounding bushings on terminations at equipment.
6. Underground Warning Tape: Comply with requirements in Section 260553 "Identification for Electrical Systems."

3.4 INSTALLATION OF UNDERGROUND HANDHOLES AND BOXES

- A. Install handholes and boxes level and plumb and with orientation and depth coordinated with connecting conduits to minimize bends and deflections required for proper entrances.
- B. Unless otherwise indicated, support units on a level bed of crushed stone or gravel, graded from 1/2-inch (12.5-mm) sieve to No. 4 (4.75-mm) sieve and compacted to same density as adjacent undisturbed earth.
- C. Elevation: In paved areas, set so cover surface will be flush with finished grade. Set covers of other enclosures 1 inch (25 mm) above finished grade.
- D. Install handholes with bottom below frost line, Insert depth of frost line below grade at Project site below grade.
- E. Field-cut openings for conduits according to enclosure manufacturer's written instructions. Cut wall of enclosure with a tool designed for material to be cut. Size holes for terminating fittings to be used, and seal around penetrations after fittings are installed.

3.5 SLEEVE AND SLEEVE-SEAL INSTALLATION FOR ELECTRICAL PENETRATIONS

- A. Install sleeves and sleeve seals at penetrations of exterior floor and wall assemblies. Comply with requirements in Section 260544 "Sleeves and Sleeve Seals for Electrical Raceways and Cabling."

3.6 FIRESTOPPING

- A. Install firestopping at penetrations of fire-rated floor and wall assemblies. Comply with requirements in Section 078413 "Penetration Firestopping."

3.7 PROTECTION

- A. Protect coatings, finishes, and cabinets from damage and deterioration.

1. Repair damage to galvanized finishes with zinc-rich paint recommended by manufacturer.
2. Repair damage to PVC coatings or paint finishes with matching touchup coating recommended by manufacturer.

END OF SECTION 26 05 33

SECTION 26 0553 - IDENTIFICATION FOR ELECTRICAL SYSTEMS

PART 1 - GENERAL

1.1 RELATED DOCUMENTS

- A. Drawings and general provisions of the Contract, including General and Supplementary Conditions and Division 01 Specification Sections, apply to this Section.

1.2 SUMMARY

- A. Section Includes:
 - 1. Color and legend requirements for raceways, conductors, and warning labels and signs.
 - 2. Labels.
 - 3. Bands and tubes.
 - 4. Tapes and stencils.
 - 5. Tags.
 - 6. Signs.
 - 7. Cable ties.
 - 8. Paint for identification.
 - 9. Fasteners for labels and signs.

1.3 ACTION SUBMITTALS

- A. Product Data: For each type of product.
- B. Samples: For each type of label and sign to illustrate composition, size, colors, lettering style, mounting provisions, and graphic features of identification products.
- C. Delegated-Design Submittal: For arc-flash hazard study.

PART 2 - PRODUCTS

2.1 PERFORMANCE REQUIREMENTS

- A. Comply with ASME A13.1 and IEEE C2.
- B. Comply with NFPA 70.
- C. Comply with 29 CFR 1910.144 and 29 CFR 1910.145.
- D. Comply with ANSI Z535.4 for safety signs and labels.
- E. Comply with NFPA 70E and Section 260573.19 "Arc-Flash Hazard Analysis" requirements for arc-flash warning labels.

- F. Adhesive-attached labeling materials, including label stocks, laminating adhesives, and inks used by label printers, shall comply with UL 969.
- G. Thermal Movements: Allow for thermal movements from ambient and surface temperature changes.
 - 1. Temperature Change: 120 deg F (67 deg C), ambient; 180 deg F (100 deg C), material surfaces.

2.2 COLOR AND LEGEND REQUIREMENTS

- A. Raceways and Cables Carrying Circuits at 600 V or Less:
 - 1. Black letters on an orange field.
 - 2. Legend: Indicate voltage and system or service type.
- B. Color-Coding for Phase- and Voltage-Level Identification, 600 V or Less: Use colors listed below for ungrounded service feeder and branch-circuit conductors.
 - 1. Color shall be factory applied or field applied for sizes larger than No. 8 AWG if authorities having jurisdiction permit.
 - 2. Colors for 208/120-V Circuits:
 - a. Phase A: Black.
 - b. Phase B: Red.
 - c. Phase C: Blue.
 - 3. Colors for 240-V Circuits:
 - a. Phase A: Black.
 - b. Phase B: Red.
 - 4. Colors for 480/277-V Circuits:
 - a. Phase A: Brown.
 - b. Phase B: Orange.
 - c. Phase C: Yellow.
 - 5. Color for Neutral: White or gray.
 - 6. Color for Equipment Grounds: Green or Green with a yellow stripe.
 - 7. Colors for Isolated Grounds: Green two or more yellow stripes.
- C. Warning Label Colors:
 - 1. Identify system voltage with black letters on an orange background.
- D. Warning labels and signs shall include, but are not limited to, the following legends:
 - 1. Multiple Power Source Warning: "DANGER - ELECTRICAL SHOCK HAZARD - EQUIPMENT HAS MULTIPLE POWER SOURCES."
 - 2. Workspace Clearance Warning: "WARNING - OSHA REGULATION - AREA IN FRONT OF ELECTRICAL EQUIPMENT MUST BE KEPT CLEAR FOR 36 INCHES (915 MM)."
- E. Equipment Identification Labels:

1. Black letters on a white field.

2.3 LABELS

- A. Vinyl Wraparound Labels: Preprinted, flexible labels laminated with a clear, weather- and chemical-resistant coating and matching wraparound clear adhesive tape for securing label ends.
 1. Manufacturers: Subject to compliance with requirements, available manufacturers offering products that may be incorporated into the Work include, but are not limited to the following:
 - a. Brady Corporation.
 - b. Champion America.
 - c. Panduit Corp.
- B. Snap-around Labels: Slit, pretensioned, flexible, preprinted, color-coded acrylic sleeves, with diameters sized to suit diameter and that stay in place by gripping action.
 1. Manufacturers: Subject to compliance with requirements, available manufacturers offering products that may be incorporated into the Work include, but are not limited to the following:
 - a. Brady Corporation.
 - b. Panduit Corp.
- C. Self-Adhesive Wraparound Labels: Preprinted, 3-mil- (0.08-mm-) thick, polyester flexible label with acrylic pressure-sensitive adhesive.
 1. Manufacturers: Subject to compliance with requirements, available manufacturers offering products that may be incorporated into the Work include, but are not limited to the following:
 - a. Brady Corporation.
 - b. Ideal Industries, Inc.
 - c. Panduit Corp.
 2. Self-Lamination: Clear; UV-, weather- and chemical-resistant; self-laminating, protective shield over the legend. Labels sized such that the clear shield overlaps the entire printed legend.
 3. Marker for Labels: Permanent, waterproof, black ink marker recommended by tag manufacturer.
 4. Marker for Labels: Machine-printed, permanent, waterproof, black ink recommended by printer manufacturer.
- D. Self-Adhesive Labels: Polyester, thermal, transfer-printed, 3-mil- (0.08-mm-) thick, multicolor, weather- and UV-resistant, pressure-sensitive adhesive labels, configured for intended use and location.
 1. Manufacturers: Subject to compliance with requirements, available manufacturers offering products that may be incorporated into the Work include, but are not limited to the following:
 - a. Brady Corporation.

- b. Ideal Industries, Inc.
 - c. Panduit Corp.
2. Minimum Nominal Size:
- a. 1-1/2 by 6 inches (37 by 150 mm) for raceway and conductors.
 - b. 3-1/2 by 5 inches (76 by 127 mm) for equipment.
 - c. As required by authorities having jurisdiction.

2.4 BANDS AND TUBES

- A. Snap-around, Color-Coding Bands: Slit, pretensioned, flexible, solid-colored acrylic sleeves, 2 inches (50 mm) long, with diameters sized to suit diameter and that stay in place by gripping action.
1. Manufacturers: Subject to compliance with requirements, available manufacturers offering products that may be incorporated into the Work include, but are not limited to the following:
- a. Brady Corporation.
 - b. Panduit Corp.
- B. Heat-Shrink Preprinted Tubes: Flame-retardant polyolefin tubes with machine-printed identification labels, sized to suit diameters of and shrunk to fit firmly around item being identified. Full shrink recovery occurs at a maximum of 200 deg F (93 deg C). Comply with UL 224.
1. Manufacturers: Subject to compliance with requirements, available manufacturers offering products that may be incorporated into the Work include, but are not limited to the following:
- a. Brady Corporation.
 - b. Panduit Corp.

2.5 TAPES AND STENCILS

- A. Marker Tapes: Vinyl or vinyl-cloth, self-adhesive wraparound type, with circuit identification legend machine printed by thermal transfer or equivalent process.
1. Manufacturers: Subject to compliance with requirements, available manufacturers offering products that may be incorporated into the Work include, but are not limited to the following:
- a. Champion America.
 - b. Ideal Industries, Inc.
 - c. Panduit Corp.
- B. Self-Adhesive Vinyl Tape: Colored, heavy duty, waterproof, fade resistant; not less than 3 mils (0.08 mm) thick by 1 to 2 inches (25 to 50 mm) wide; compounded for outdoor use.
1. Manufacturers: Subject to compliance with requirements, available manufacturers offering products that may be incorporated into the Work include, but are not limited to the following:

- a. Brady Corporation.
- C. Tape and Stencil: 4-inch- (100-mm-) wide black stripes on 10-inch (250-mm) centers placed diagonally over orange background and is 12 inches (300 mm) wide. Stop stripes at legends.
- 1. Manufacturers: Subject to compliance with requirements, available manufacturers offering products that may be incorporated into the Work include, but are not limited to the following:
 - a. LEM Products Inc.
 - b. Seton Identification Products; a Brady Corporation company.
- D. Floor Marking Tape: 2-inch- (50-mm-) wide, 5-mil (0.125-mm) pressure-sensitive vinyl tape, with **yellow and black** stripes and clear vinyl overlay.
- 1. Manufacturers: Subject to compliance with requirements, available manufacturers offering products that may be incorporated into the Work include, but are not limited to the following:
 - a. Carlton Industries, LP.
 - b. Seton Identification Products; a Brady Corporation company.
- E. Underground-Line Warning Tape:
- 1. Manufacturers: Subject to compliance with requirements, available manufacturers offering products that may be incorporated into the Work include, but are not limited to the following:
 - a. Brady Corporation.
 - b. Ideal Industries, Inc.
 - 2. Tape:
 - a. Recommended by manufacturer for the method of installation and suitable to identify and locate underground electrical and communications utility lines.
 - b. Printing on tape shall be permanent and shall not be damaged by burial operations.
 - c. Tape material and ink shall be chemically inert and not subject to degradation when exposed to acids, alkalis, and other destructive substances commonly found in soils.
 - 3. Color and Printing:
 - a. Comply with ANSI Z535.1, ANSI Z535.2, ANSI Z535.3, ANSI Z535.4, and ANSI Z535.5.
 - b. Inscriptions for Red-Colored Tapes: "ELECTRIC LINE, HIGH VOLTAGE".
 - c. Inscriptions for Orange-Colored Tapes: "TELEPHONE CABLE, CATV CABLE, COMMUNICATIONS CABLE, OPTICAL FIBER CABLE".
 - 4. Tag: Type I:
 - a. Pigmented polyolefin, bright colored, continuous-printed on one side with the inscription of the utility, compounded for direct-burial service.
 - b. Width: 3 inches (75 mm).
 - c. Thickness: 4 mils (0.1 mm).

- d. Weight: 18.5 lb/1000 sq. ft. (9.0 kg/100 sq. m).
 - e. Tensile according to ASTM D882: 30 lbf (133.4 N) and 2500 psi (17.2 MPa).
5. Tag: Type ID:
- a. Detectable three-layer laminate, consisting of a printed pigmented polyolefin film, a solid aluminum-foil core, and a clear protective film that allows inspection of the continuity of the conductive core; bright colored, continuous-printed on one side with the inscription of the utility, compounded for direct-burial service.
 - b. Width: 3 inches (75 mm).
 - c. Overall Thickness: 5 mils (0.125 mm).
 - d. Foil Core Thickness: 0.35 mil (0.00889 mm).
 - e. Weight: 28 lb/1000 sq. ft. (13.7 kg/100 sq. m).
 - f. Tensile according to ASTM D882: 70 lbf (311.3 N) and 4600 psi (31.7 MPa).
- F. Stenciled Legend: In nonfading, waterproof, black ink or paint. Minimum letter height shall be 1 inch (25 mm).

2.6 TAGS

A. Write-on Tags:

1. Manufacturers: Subject to compliance with requirements, available manufacturers offering products that may be incorporated into the Work include, but are not limited to the following:
 - a. LEM Products Inc.
 - b. Seton Identification Products; a Brady Corporation company.
2. Polyester Tags: 0.015 inch (0.38 mm) thick, with corrosion-resistant grommet and cable tie for attachment.
3. Marker for Tags: Permanent, waterproof, black ink marker recommended by tag manufacturer.
4. Marker for Tags: Machine-printed, permanent, waterproof, black ink marker recommended by printer manufacturer.

2.7 SIGNS

A. Baked-Enamel Signs:

1. Manufacturers: Subject to compliance with requirements, available manufacturers offering products that may be incorporated into the Work include, but are not limited to the following:
 - a. Carlton Industries, LP.
 - b. Champion America.
2. Preprinted aluminum signs, high-intensity reflective, punched or drilled for fasteners, with colors, legend, and size required for application.
3. 1/4-inch (6.4-mm) grommets in corners for mounting.
4. Nominal Size: 7 by 10 inches (180 by 250 mm).

B. Metal-Backed Butyrate Signs:

1. Manufacturers: Subject to compliance with requirements, available manufacturers offering products that may be incorporated into the Work include, but are not limited to the following:
 - a. Brady Corporation.
 - b. Champion America.
2. Weather-resistant, nonfading, preprinted, cellulose-acetate butyrate signs, with 0.0396-inch (1-mm) galvanized-steel backing, punched and drilled for fasteners, and with colors, legend, and size required for application.
3. 1/4-inch (6.4-mm) grommets in corners for mounting.
4. Nominal Size: 10 by 14 inches (250 by 360 mm).

C. Laminated Acrylic or Melamine Plastic Signs:

1. Manufacturers: Subject to compliance with requirements, available manufacturers offering products that may be incorporated into the Work include, but are not limited to the following:
 - a. Brady Corporation.
 - b. Carlton Industries, LP.
2. Engraved legend.
3. Thickness:
 - a. For signs up to 20 sq. in. (129 sq. cm), minimum 1/16 inch (1.6 mm) thick.
 - b. For signs larger than 20 sq. in. (129 sq. cm), 1/8 inch (3.2 mm) thick.
 - c. Engraved legend with black letters on white face.
 - d. Punched or drilled for mechanical fasteners with 1/4-inch (6.4-mm) grommets in corners for mounting.
 - e. Framed with mitered acrylic molding and arranged for attachment at applicable equipment.

2.8 CABLE TIES

- A. Manufacturers: Subject to compliance with requirements, available manufacturers offering products that may be incorporated into the Work include, but are not limited to the following:
 1. Ideal Industries, Inc.
 2. Panduit Corp.
- B. General-Purpose Cable Ties: Fungus inert, self-extinguishing, one piece, self-locking, and Type 6/6 nylon.
 1. Minimum Width: 3/16 inch (5 mm).
 2. Tensile Strength at 73 Deg F (23 Deg C) according to ASTM D638: 12,000 psi (82.7 MPa).
 3. Temperature Range: Minus 40 to plus 185 deg F (Minus 40 to plus 85 deg C).
 4. Color: Black, except where used for color-coding.
- C. UV-Stabilized Cable Ties: Fungus inert, designed for continuous exposure to exterior sunlight, self-extinguishing, one piece, self-locking, and Type 6/6 nylon.
 1. Minimum Width: 3/16 inch (5 mm).

2. Tensile Strength at 73 Deg F (23 Deg C) according to ASTM D638: 12,000 psi (82.7 MPa).
3. Temperature Range: Minus 40 to plus 185 deg F (Minus 40 to plus 85 deg C).
4. Color: Black.

D. Plenum-Rated Cable Ties: Self-extinguishing, UV stabilized, one piece, and self-locking.

1. Minimum Width: 3/16 inch (5 mm).
2. Tensile Strength at 73 Deg F (23 Deg C) according to ASTM D638: 7000 psi (48.2 MPa).
3. UL 94 Flame Rating: 94V-0.
4. Temperature Range: Minus 50 to plus 284 deg F (Minus 46 to plus 140 deg C).
5. Color: Black.

2.9 MISCELLANEOUS IDENTIFICATION PRODUCTS

- A. Paint: Comply with requirements in painting Sections for paint materials and application requirements. Retain paint system applicable for surface material and location (exterior or interior).
- B. Fasteners for Labels and Signs: Self-tapping, stainless-steel screws or stainless-steel machine screws with nuts and flat and lock washers.

PART 3 - EXECUTION

3.1 INSTALLATION

- A. Verify and coordinate identification names, abbreviations, colors, and other features with requirements in other Sections requiring identification applications, Drawings, Shop Drawings, manufacturer's wiring diagrams, and operation and maintenance manual. Use consistent designations throughout Project.
- B. Install identifying devices before installing acoustical ceilings and similar concealment.
- C. Verify identity of each item before installing identification products.
- D. Coordinate identification with Project Drawings, manufacturer's wiring diagrams, and operation and maintenance manual.
- E. Apply identification devices to surfaces that require finish after completing finish work.
- F. Install signs with approved legend to facilitate proper identification, operation, and maintenance of electrical systems and connected items.
- G. Self-Adhesive Identification Products: Before applying electrical identification products, clean substrates of substances that could impair bond, using materials and methods recommended by manufacturer of identification product.
- H. System Identification for Raceways and Cables under 600 V: Identification shall completely encircle cable or conduit. Place identification of two-color markings in contact, side by side.
 1. Secure tight to surface of conductor, cable, or raceway.

- I. System Identification for Raceways and Cables over 600 V: Identification shall completely encircle cable or conduit. Place adjacent identification of two-color markings in contact, side by side.
 - 1. Secure tight to surface of conductor, cable, or raceway.
- J. Auxiliary Electrical Systems Conductor Identification: Identify field-installed alarm, control, and signal connections.
- K. Emergency Operating Instruction Signs: Install instruction signs with white legend on a red background with minimum 3/8-inch- (10-mm-) high letters for emergency instructions at equipment used for power transfer and/or load shedding.
- L. Elevated Components: Increase sizes of labels, signs, and letters to those appropriate for viewing from the floor.
- M. Accessible Fittings for Raceways: Identify the covers of each junction and pull box of the following systems with the wiring system legend and system voltage. System legends shall be as follows:
 - 1. "EMERGENCY POWER."
 - 2. "POWER."
 - 3. "UPS."
- N. Vinyl Wraparound Labels:
 - 1. Secure tight to surface at a location with high visibility and accessibility.
 - 2. Attach labels that are not self-adhesive type with clear vinyl tape, with adhesive appropriate to the location and substrate.
- O. Snap-around Labels: Secure tight to surface at a location with high visibility and accessibility.
- P. Self-Adhesive Wraparound Labels: Secure tight to surface of raceway or cable at a location with high visibility and accessibility.
- Q. Self-Adhesive Labels:
 - 1. On each unit of equipment, install unique designation label that is consistent with wiring diagrams, schedules, and operation and maintenance manual.
 - 2. Unless otherwise indicated, provide a single line of text with 1/2-inch- (13-mm-) high letters on 1-1/2-inch- (38-mm-) high label; where two lines of text are required, use labels 2 inches (50 mm) high.
- R. Snap-around Color-Coding Bands: Secure tight to surface at a location with high visibility and accessibility.
- S. Heat-Shrink, Preprinted Tubes: Secure tight to surface at a location with high visibility and accessibility.
- T. Marker Tapes: Secure tight to surface at a location with high visibility and accessibility.
- U. Self-Adhesive Vinyl Tape: Secure tight to surface at a location with high visibility and accessibility.

1. Field-Applied, Color-Coding Conductor Tape: Apply in half-lapped turns for a minimum distance of 6 inches (150 mm) where splices or taps are made. Apply last two turns of tape with no tension to prevent possible unwinding.
- V. Tape and Stencil: Comply with requirements in painting Sections for surface preparation and paint application.
- W. Floor Marking Tape: Apply stripes to finished surfaces following manufacturer's written instructions.
- X. Underground Line Warning Tape:
1. During backfilling of trenches, install continuous underground-line warning tape directly above cable or raceway at 6 to 8 inches (150 to 200 mm) below finished grade. Use multiple tapes where width of multiple lines installed in a common trench or concrete envelope exceeds 16 inches (400 mm) overall.
 2. Limit use of underground-line warning tape to direct-buried cables.
 3. Install underground-line warning tape for direct-buried cables and cables in raceways.
- Y. Write-on Tags:
1. Place in a location with high visibility and accessibility.
 2. Secure using UV-stabilized cable ties.
- Z. Baked-Enamel Signs:
1. Attach signs that are not self-adhesive type with mechanical fasteners appropriate to the location and substrate.
 2. Unless otherwise indicated, provide a single line of text with 1/2-inch- (13-mm-) high letters on minimum 1-1/2-inch- (38-mm-) high sign; where two lines of text are required, use signs minimum 2 inches (50 mm) high.
- AA. Metal-Backed Butyrate Signs:
1. Attach signs that are not self-adhesive type with mechanical fasteners appropriate to the location and substrate.
 2. Unless otherwise indicated, provide a single line of text with 1/2-inch- (13-mm-) high letters on minimum 1-1/2-inch- (38-mm-) high sign; where two lines of text are required, use signs minimum 2 inches (50 mm) high.
- BB. Laminated Acrylic or Melamine Plastic Signs:
1. Attach signs and plastic labels that are not self-adhesive type with mechanical fasteners appropriate to the location and substrate.
 2. Unless otherwise indicated, provide a single line of text with 1/2-inch- (13-mm-) high letters on minimum 1-1/2-inch- (38-mm-) high sign; where two lines of text are required, use signs minimum 2 inches (50 mm) high.
- CC. Cable Ties: General purpose, for attaching tags, except as listed below:
1. Outdoors: UV-stabilized nylon.
 2. In Spaces Handling Environmental Air: Plenum rated.

3.2 IDENTIFICATION SCHEDULE

- A. Install identification materials and devices at locations for most convenient viewing without interference with operation and maintenance of equipment. Install access doors or panels to provide view of identifying devices.
- B. Identify conductors, cables, and terminals in enclosures and at junctions, terminals, pull points, and locations of high visibility. Identify by system and circuit designation.
- C. Accessible Raceways and Metal-Clad Cables, 600 V or Less, for Service, Feeder, and Branch Circuits, More Than 30 A and 120 V to Ground: Identify with self-adhesive raceway labels.
 - 1. Locate identification at changes in direction, at penetrations of walls and floors, at 50-foot (15-m) maximum intervals in straight runs, and at 25-foot (7.6-m) maximum intervals in congested areas.
- D. Accessible Fittings for Raceways and Cables within Buildings: Identify the covers of each junction and pull box of the following systems with self-adhesive labels containing the wiring system legend and system voltage. System legends shall be as follows:
 - 1. "EMERGENCY POWER."
 - 2. "POWER."
 - 3. "UPS."
- E. Power-Circuit Conductor Identification, 600 V or Less: For conductors in vaults, pull and junction boxes, manholes, and handholes, use snap-around labels to identify the phase.
 - 1. Locate identification at changes in direction, at penetrations of walls and floors, at 50-foot (15-m) maximum intervals in straight runs, and at 25-foot (7.6-m) maximum intervals in congested areas.
- F. Control-Circuit Conductor Identification: For conductors and cables in pull and junction boxes, manholes, and handholes, use self-adhesive wraparound labels with the conductor or cable designation, origin, and destination.
- G. Control-Circuit Conductor Termination Identification: For identification at terminations, provide heat-shrink preprinted tubes with the conductor designation.
- H. Conductors to Be Extended in the Future: Attach write-on tags to conductors and list source.
- I. Auxiliary Electrical Systems Conductor Identification: Self-adhesive vinyl tape that is uniform and consistent with system used by manufacturer for factory-installed connections.
 - 1. Identify conductors, cables, and terminals in enclosures and at junctions, terminals, and pull points. Identify by system and circuit designation.
- J. Locations of Underground Lines: Underground-line warning tape for power, lighting, communication, and control wiring and optical-fiber cable.
- K. Workspace Indication: Apply floor marking tape or tape and stencil to finished surfaces. Show working clearances in the direction of access to live parts. Workspace shall comply with NFPA 70 and 29 CFR 1926.403 unless otherwise indicated. Do not install at flush-mounted panelboards and similar equipment in finished spaces.

- L. Instructional Signs: Self-adhesive labels, including the color code for grounded and ungrounded conductors.
- M. Warning Labels for Indoor Cabinets, Boxes, and Enclosures for Power and Lighting: Baked-enamel warning signs.
 - 1. Apply to exterior of door, cover, or other access.
 - 2. For equipment with multiple power or control sources, apply to door or cover of equipment, including, but not limited to, the following:
 - a. Power-transfer switches.
 - b. Controls with external control power connections.
- N. Arc Flash Warning Labeling: Self-adhesive labels.
- O. Operating Instruction Signs: Baked-enamel warning signs.
- P. Emergency Operating Instruction Signs: Baked-enamel warning signs with white legend on a red background with minimum 3/8-inch- (10-mm-) high letters for emergency instructions at equipment used for power transfer and/or load shedding.
- Q. Equipment Identification Labels:
 - 1. Indoor Equipment: Baked-enamel signs.
 - 2. Outdoor Equipment: Laminated acrylic or melamine sign.

END OF SECTION 26 05 53

SECTION 262816
ENCLOSED SWITCHES AND CIRCUIT BREAKERS

PART 1 - GENERAL

1.01 SUMMARY

- A. Section Includes:
 - 1. Fusible switches.
 - 2. Nonfusible switches.
 - 3. Receptacle switches.
 - 4. Shunt trip switches.
 - 5. Molded-case circuit breakers (MCCBs).
 - 6. Molded-case switches.
 - 7. Enclosures.

1.02 ACTION SUBMITTALS

- A. Product Data: For each type of enclosed switch, circuit breaker, accessory, and component indicated. Include nameplate ratings, dimensioned elevations, sections, weights, and manufacturers' technical data on features, performance, electrical characteristics, ratings, accessories, and finishes.
 - 1. Include time-current coordination curves (average melt) for each type and rating of overcurrent protective device; include selectable ranges for each type of overcurrent protective device. Provide in PDF electronic format.
- B. Shop Drawings: For enclosed switches and circuit breakers.
 - 1. Include plans, elevations, sections, details, and attachments to other work.
 - 2. Include wiring diagrams for power, signal, and control wiring.

1.03 INFORMATIONAL SUBMITTALS

- A. Qualification Data: For qualified testing agency.
- B. Field quality-control reports.

1.04 CLOSEOUT SUBMITTALS

- A. Operation and maintenance data.

1.05 QUALITY ASSURANCE

- A. Testing Agency Qualifications: Accredited by NETA.
 - 1. Testing Agency's Field Supervisor: Currently certified by NETA to supervise on-site testing.

1.06 WARRANTY

- A. Manufacturer's Warranty: Manufacturer and Installer agree to repair or replace components that fail in materials or workmanship within specified warranty period.

1. Warranty Period: One year from date of Substantial Completion.

PART 2 - PRODUCTS

2.01 GENERAL REQUIREMENTS

- A. Source Limitations: Obtain enclosed switches and circuit breakers, overcurrent protective devices, components, and accessories, within same product category, from single manufacturer.
- B. Product Selection for Restricted Space: Drawings indicate maximum dimensions for enclosed switches and circuit breakers, including clearances between enclosures, and adjacent surfaces and other items. Comply with indicated maximum dimensions.
- C. Electrical Components, Devices, and Accessories: Listed and labeled as defined in NFPA 70, by an NRTL, and marked for intended location and application.
- D. Comply with NFPA 70.

2.02 FUSIBLE SWITCHES

- A. Manufacturers: Subject to compliance with requirements, provide products by one of the following:
 1. Eaton.
 2. Schneider Electric USA (Square D).
- B. Type HD, Heavy Duty:
 1. Single throw.
 2. Three pole.
 3. 240 and 600-V ac.
 4. 1200 A and smaller.
 5. UL 98 and NEMA KS 1, horsepower rated, with clips or bolt pads to accommodate fuses per equipment manufacturer's recommendations.
 6. Lockable handle with capability to accept three padlocks, and interlocked with cover in closed position.
- C. Accessories:
 1. Equipment Ground Kit: Internally mounted and labeled for copper and aluminum ground conductors.
 2. Neutral Kit: Internally mounted; insulated, capable of being grounded and bonded; labeled for copper and aluminum neutral conductors.
 3. Isolated Ground Kit: Internally mounted; insulated, labeled for copper and aluminum neutral conductors.
 4. Class R Fuse Kit: Provides rejection of other fuse types when Class R fuses are specified.
 5. Service-Rated Switches: Labeled for use as service equipment.

2.03 NONFUSIBLE SWITCHES

- A. Manufacturers: Subject to compliance with requirements, provide products by one of the following:

1. Eaton.
 2. Schneider Electric USA (Square D).
- B. Type HD, Heavy Duty, Three Pole, Single Throw, 240 and 600-V ac, 1200 A and Smaller: UL 98 and NEMA KS 1, horsepower rated, lockable handle with capability to accept three padlocks, and interlocked with cover in closed position.
- C. Accessories:
1. Equipment Ground Kit: Internally mounted and labeled for copper and aluminum ground conductors.
 2. Neutral Kit: Internally mounted; insulated, capable of being grounded and bonded; labeled for copper and aluminum neutral conductors.
 3. Isolated Ground Kit: Internally mounted; insulated, labeled for copper and aluminum neutral conductors.
 4. Class R Fuse Kit: Provides rejection of other fuse types when Class R fuses are specified.
 5. Service-Rated Switches: Labeled for use as service equipment.

2.04 RECEPTACLE SWITCHES

- A. Manufacturers: Subject to compliance with requirements, provide products by one of the following:
1. Eaton.
 2. Schneider Electric USA (Square D).
- B. Type HD, Heavy-Duty, Three Pole, Single-Throw Fusible Switch: 240 and 600-V ac, 30, 60, and 100 A; UL 98 and NEMA KS 1; horsepower rated, with clips or bolt pads to accommodate fuses per equipment manufacturer's recommendations; lockable handle with capability to accept three padlocks; interlocked with cover in closed position.
- C. Type HD, Heavy-Duty, Three Pole, Single-Throw Nonfusible Switch: 240 and 600-V ac, 30, 60, and 100 A; UL 98 and NEMA KS 1; horsepower rated, lockable handle with capability to accept three padlocks; interlocked with cover in closed position.
- D. Interlocking Linkage: Provided between the receptacle and switch mechanism to prevent inserting or removing plug while switch is in the on position, inserting any plug other than specified, and turning switch on if an incorrect plug is inserted or correct plug has not been fully inserted into the receptacle.
- E. Receptacle: Polarized, three-phase, four-wire receptacle (fourth wire connected to enclosure ground lug).
- F. Accessories:
1. Equipment Ground Kit: Internally mounted and labeled for copper and aluminum ground conductors.
 2. Neutral Kit: Internally mounted; insulated, capable of being grounded and bonded; labeled for copper and aluminum neutral conductors.
 3. Isolated Ground Kit: Internally mounted; insulated, labeled for copper and aluminum neutral conductors.
 4. Class R Fuse Kit: Provides rejection of other fuse types when Class R fuses are specified.
 5. Auxiliary Contact Kit: Two NO/NC (Form "C") auxiliary contact(s), arranged to activate before switch blades open. Contact rating - 120-V ac.

6. Hookstick Handle: Allows use of a hookstick to operate the handle.
7. Lugs: Mechanical type, suitable for number, size, and conductor material.
8. Service-Rated Switches: Labeled for use as service equipment.

2.05 SHUNT TRIP SWITCHES

- A. Manufacturers: Subject to compliance with requirements, provide products by one of the following:
 1. Eaton (Bussmann & Edison).
 2. Littelfuse, Inc.
- B. General Requirements: Comply with ASME A17.1, UL 50, and UL 98, with Class J fuse block and 200-kA interrupting and short-circuit current rating.
- C. Type HD, Heavy-Duty, Three Pole, Single-Throw Fusible Switch: 240 and 600-V ac, 30, 60, and 100 A; UL 98 and NEMA KS 1; integral shunt trip mechanism; horsepower rated, with clips or bolt pads to accommodate fuses per equipment manufacturer's recommendations; lockable handle with capability to accept three padlocks; interlocked with cover in closed position.
- D. Type HD, Heavy-Duty, Three Pole, Single-Throw Nonfusible Switch: 240 and 600-V ac, 30, 60, and 100 A; UL 98 and NEMA KS 1; integral shunt trip mechanism; horsepower rated, lockable handle with capability to accept three padlocks; interlocked with cover in closed position.
- E. Control Circuit: 120-V ac; obtained from integral control power transformer, with primary and secondary fuses, with a control power source of enough capacity to operate shunt trip, pilot, indicating and control devices.
- F. Accessories:
 1. Oiltight key switch for key-to-test function.
 2. Oiltight green ON pilot light.
 3. Isolated neutral lug; 100 percent rating.
 4. Mechanically interlocked auxiliary contacts that change state when switch is opened and closed.
 5. Three-pole, double-throw, fire-safety and alarm relay; coil voltage shall match fire-alarm system.
 6. Three-pole, double-throw, fire-alarm voltage monitoring relay complying with NFPA 72.
 7. Neutral Kit: Internally mounted; insulated, capable of being grounded and bonded; labeled for copper and aluminum neutral conductors.
 8. Isolated Ground Kit: Internally mounted; insulated, labeled for copper and aluminum neutral conductors.
 9. Class R Fuse Kit: Provides rejection of other fuse types when Class R fuses are specified.
 10. Service-Rated Switches: Labeled for use as service equipment.

2.06 MOLDED-CASE CIRCUIT BREAKERS

- A. Manufacturers: Subject to compliance with requirements, provide products by one of the following:
 1. Eaton.
 2. Schneider Electric USA (Square D).
- B. Circuit breakers shall be constructed using glass-reinforced insulating material. Current carrying

components shall be completely isolated from the handle and the accessory mounting area.

- C. Circuit breakers shall have a toggle operating mechanism with common tripping of all poles, which provides quick-make, quick-break contact action. The circuit-breaker handle shall be over center, be trip free, and reside in a tripped position between on and off to provide local trip indication. Circuit-breaker escutcheon shall be clearly marked on and off in addition to providing international I/O markings. Equip circuit breaker with a push-to-trip button, located on the face of the circuit breaker to mechanically operate the circuit-breaker tripping mechanism for maintenance and testing purposes.
- D. The maximum ampere rating and UL, IEC, or other certification standards with applicable voltage systems and corresponding interrupting ratings shall be clearly marked on face of circuit breaker. Circuit breakers shall be series rated. Circuit breaker/circuit breaker combinations for series connected interrupting ratings shall be listed by UL as recognized component combinations. Any series rated combination used shall be marked on the end-use equipment along with the statement "Caution - Series Rated System. _____ Amps Available. Identical Replacement Component Required."
- E. MCCBs shall be equipped with a device for locking in the isolated position.
- F. Lugs shall be suitable for 194 deg F (90 deg C) rated wire, sized according to the 167 deg F (75 deg C) temperature rating in NFPA 70.
- G. Standards: Comply with UL 489 with interrupting capacity to comply with available fault currents.
- H. Thermal-Magnetic Circuit Breakers: Inverse time-current thermal element for low-level overloads and instantaneous magnetic trip element for short circuits. Adjustable magnetic trip setting for circuit-breaker frame sizes 250 A and larger.
- I. Adjustable, Instantaneous-Trip Circuit Breakers: Magnetic trip element with front-mounted, field-adjustable trip setting.
- J. Electronic Trip Circuit Breakers: Field-replaceable rating plug, rms sensing, with the following field-adjustable settings:
 - 1. Long- and short-time pickup levels.
 - 2. Long- and short-time time adjustments.
 - 3. Ground-fault pickup level, time delay, and I-squared t response.
- K. Current-Limiting Circuit Breakers: Frame sizes 400 A and smaller, and let-through ratings less than NEMA FU 1, RK-5.
- L. Features and Accessories:
 - 1. Standard frame sizes, trip ratings, and number of poles.
 - 2. Application Listing: Appropriate for application; Type SWD for switching fluorescent lighting loads; Type HID for feeding fluorescent and high-intensity discharge lighting circuits.
 - 3. Shunt Trip: Trip coil energized from separate circuit, with coil-clearing contact.
 - 4. Auxiliary Contacts: Two SPDT switches with "a" and "b" contacts; "a" contacts mimic circuit-breaker contacts, "b" contacts operate in reverse of circuit-breaker contacts.
 - 5. Alarm Switch: One NO contact that operates only when circuit breaker has tripped.

2.07 ENCLOSURES

- A. Enclosed Switches and Circuit Breakers: UL 489, NEMA KS 1, NEMA 250, and UL 50, to comply with environmental conditions at installed location.
- B. Enclosure Finish: The enclosure shall be finished with gray baked enamel paint, electrodeposited on cleaned, phosphatized steel (NEMA 250 Type 1) gray baked enamel paint, electrodeposited on cleaned, phosphatized galvanized steel (NEMA 250 Types 3R, 12) a brush finish on Type 304 stainless steel (NEMA 250 Type 4-4X stainless steel) copper-free cast aluminum alloy (NEMA 250 Types 7, 9).
- C. Conduit Entry: NEMA 250 Types 4, 4X, and 12 enclosures shall contain no knockouts. NEMA 250 Types 7 and 9 enclosures shall be provided with threaded conduit openings in both endwalls.
- D. Operating Mechanism: The circuit-breaker operating handle shall be directly operable through the front cover of the enclosure (NEMA 250 Type 1) directly operable through the dead front trim of the enclosure (NEMA 250 Type 3R) externally operable with the operating mechanism being an integral part of the cover (NEMA 250 Types 7, 9). The cover interlock mechanism shall have an externally operated override. The override shall not permanently disable the interlock mechanism, which shall return to the locked position once the override is released. The tool used to override the cover interlock mechanism shall not be required to enter the enclosure in order to override the interlock.
- E. Enclosures designated as NEMA 250 Type 4, 4X stainless steel, 12, or 12K shall have a dual cover interlock mechanism to prevent unintentional opening of the enclosure cover when the circuit breaker is ON and to prevent turning the circuit breaker ON when the enclosure cover is open.
- F. NEMA 250 Type 7/9 enclosures shall be furnished with a breather and drain kit to allow their use in outdoor and wet location applications.

PART 3 - EXECUTION

3.01 ENCLOSURE ENVIRONMENTAL RATING APPLICATIONS

- A. Enclosed Switches and Circuit Breakers: Provide enclosures at installed locations with the following environmental ratings.
 - 1. Indoor, Dry and Clean Locations: NEMA 250, Type 1.
 - 2. Outdoor Locations: NEMA 250, Type 3R.
 - 3. Kitchen /Wash-Down Areas: NEMA 250, Type 4X, stainless steel.
 - 4. Other Wet or Damp, Indoor Locations: NEMA 250, Type 4.
 - 5. Indoor Locations Subject to Dust, Falling Dirt, and Dripping Noncorrosive Liquids: NEMA 250, Type 12.
 - 6. Hazardous Areas Indicated on Drawings: NEMA 250, Type 9 with cover attached by Type 316 stainless steel bolts.

3.02 INSTALLATION

- A. Interruption of Existing Electric Service: Do not interrupt electric service to facilities occupied by Owner or others unless permitted under the following conditions and then only after arranging to provide temporary electric service according to requirements indicated:
 - 1. Notify Architect, Construction Manager, and Owner no fewer than seven days in advance

- 2. of proposed interruption of electric service.
 - 2. Indicate method of providing temporary electric service.
 - 3. Do not proceed with interruption of electric service without Architect's written permission.
 - 4. Comply with NFPA 70E.
- B. Coordinate layout and installation of switches, circuit breakers, and components with equipment served and adjacent surfaces. Maintain required workspace clearances and required clearances for equipment access doors and panels.
 - C. Install individual wall-mounted switches and circuit breakers with tops at uniform height unless otherwise indicated.
 - D. Temporary Lifting Provisions: Remove temporary lifting of eyes, channels, and brackets and temporary blocking of moving parts from enclosures and components.
 - E. Install fuses in fusible devices.
 - F. Comply with NFPA 70 and NECA 1.
 - G. Set field-adjustable circuit-breaker trip ranges to values indicated on the Drawings.

3.03 IDENTIFICATION

- A. Comply with requirements in Section 260553 "Identification for Electrical Systems."
 - 1. Identify field-installed conductors, interconnecting wiring, and components; provide warning signs.
 - 2. Label each enclosure with engraved metal or laminated-plastic nameplate.

3.04 FIELD QUALITY CONTROL

- A. Testing Agency: Owner will engage a qualified testing agency to perform tests and inspections.
- B. Testing Agency: Engage a qualified testing agency to perform tests and inspections.
- C. Perform tests and inspections.
- D. Tests and Inspections for Switches:
 - 1. Visual and Mechanical Inspection:
 - a. Inspect physical and mechanical condition.
 - b. Inspect anchorage, alignment, grounding, and clearances.
 - c. Verify that the unit is clean.
 - d. Verify blade alignment, blade penetration, travel stops, and mechanical operation.
 - e. Verify that fuse sizes and types match the Specifications and Drawings.
 - f. Verify that each fuse has adequate mechanical support and contact integrity.
 - g. Inspect bolted electrical connections for high resistance using one of the two following methods:
 - 1) Use a low-resistance ohmmeter.
 - a) Compare bolted connection resistance values to values of similar connections. Investigate values that deviate from those of similar

bolted connections by more than 50 percent of the lowest value.

- 2) Verify tightness of accessible bolted electrical connections by calibrated torque-wrench method in accordance with manufacturer's published data or NETA ATS Table 100.12.
 - a) Bolt-torque levels shall be in accordance with manufacturer's published data. In the absence of manufacturer's published data, use NETA ATS Table 100.12.
- h. Verify that operation and sequencing of interlocking systems is as described in the Specifications and shown on the Drawings.
- i. Verify correct phase barrier installation.
- j. Verify lubrication of moving current-carrying parts and moving and sliding surfaces.

2. Electrical Tests:

- a. Perform resistance measurements through bolted connections with a low-resistance ohmmeter. Compare bolted connection resistance values to values of similar connections. Investigate values that deviate from adjacent poles or similar switches by more than 50 percent of the lowest value.
- b. Measure contact resistance across each switchblade fuseholder. Drop values shall not exceed the high level of the manufacturer's published data. If manufacturer's published data are not available, investigate values that deviate from adjacent poles or similar switches by more than 50 percent of the lowest value.
- c. Perform insulation-resistance tests for one minute on each pole, phase-to-phase and phase-to-ground with switch closed, and across each open pole. Apply voltage in accordance with manufacturer's published data. In the absence of manufacturer's published data, use Table 100.1 from the NETA ATS. Investigate values of insulation resistance less than those published in Table 100.1 or as recommended in manufacturer's published data.
- d. Measure fuse resistance. Investigate fuse-resistance values that deviate from each other by more than 15 percent.
- e. Perform ground fault test according to NETA ATS 7.14 "Ground Fault Protection Systems, Low-Voltage."

E. Tests and Inspections for Molded Case Circuit Breakers:

1. Visual and Mechanical Inspection:

- a. Verify that equipment nameplate data are as described in the Specifications and shown on the Drawings.
- b. Inspect physical and mechanical condition.
- c. Inspect anchorage, alignment, grounding, and clearances.
- d. Verify that the unit is clean.
- e. Operate the circuit breaker to ensure smooth operation.
- f. Inspect bolted electrical connections for high resistance using one of the two following methods:
 - 1) Use a low-resistance ohmmeter.
 - a) Compare bolted connection resistance values to values of similar connections. Investigate values that deviate from those of similar bolted connections by more than 50 percent of the lowest value.

- 2) Verify tightness of accessible bolted electrical connections by calibrated torque-wrench method in accordance with manufacturer's published data or NETA ATS Table 100.12.
 - a) Bolt-torque levels shall be in accordance with manufacturer's published data. In the absence of manufacturer's published data, use NETA ATS Table 100.12.
- g. Inspect operating mechanism, contacts, and chutes in unsealed units.
- h. Perform adjustments for final protective device settings in accordance with the coordination study.

2. Electrical Tests:

- a. Perform resistance measurements through bolted connections with a low-resistance ohmmeter. Compare bolted connection resistance values to values of similar connections. Investigate values that deviate from adjacent poles or similar switches by more than 50 percent of the lowest value.
- b. Perform insulation-resistance tests for one minute on each pole, phase-to-phase and phase-to-ground with circuit breaker closed, and across each open pole. Apply voltage in accordance with manufacturer's published data. In the absence of manufacturer's published data, use Table 100.1 from the NETA ATS. Investigate values of insulation resistance less than those published in Table 100.1 or as recommended in manufacturer's published data.
- c. Perform a contact/pole resistance test. Drop values shall not exceed the high level of the manufacturer's published data. If manufacturer's published data are not available, investigate values that deviate from adjacent poles or similar switches by more than 50 percent of the lowest value.
- d. Perform insulation resistance tests on all control wiring with respect to ground. Applied potential shall be 500-V dc for 300-V rated cable and 1000-V dc for 600-V rated cable. Test duration shall be one minute. For units with solid state components, follow manufacturer's recommendation. Insulation resistance values shall be no less than two megohms.
- e. Determine the following by primary current injection:
 - 1) Long-time pickup and delay. Pickup values shall be as specified. Trip characteristics shall not exceed manufacturer's published time-current characteristic tolerance band, including adjustment factors.
 - 2) Short-time pickup and delay. Short-time pickup values shall be as specified. Trip characteristics shall not exceed manufacturer's published time-current characteristic tolerance band, including adjustment factors.
 - 3) Ground-fault pickup and time delay. Ground-fault pickup values shall be as specified. Trip characteristics shall not exceed manufacturer's published time-current characteristic tolerance band, including adjustment factors.
 - 4) Instantaneous pickup. Instantaneous pickup values shall be as specified and within manufacturer's published tolerances.
- f. Test functionality of the trip unit by means of primary current injection. Pickup values and trip characteristics shall be as specified and within manufacturer's published tolerances.
- g. Perform minimum pickup voltage tests on shunt trip and close coils in accordance with manufacturer's published data. Minimum pickup voltage of the shunt trip and close coils shall be as indicated by manufacturer.
- h. Verify correct operation of auxiliary features such as trip and pickup indicators; zone interlocking; electrical close and trip operation; trip-free, anti-pump function; and trip

unit battery condition. Reset all trip logs and indicators. Investigate units that do not function as designed.

- i. Verify operation of charging mechanism. Investigate units that do not function as designed.
 3. Correct malfunctioning units on-site, where possible, and retest to demonstrate compliance; otherwise, replace with new units and retest.
 4. Test and adjust controls, remote monitoring, and safeties. Replace damaged and malfunctioning controls and equipment.
- F. Enclosed switches and circuit breakers will be considered defective if they do not pass tests and inspections.
- G. Prepare test and inspection reports.
1. Test procedures used.
 2. Include identification of each enclosed switch and circuit breaker tested and describe test results.
 3. List deficiencies detected, remedial action taken, and observations after remedial action.

END OF SECTION

AIR HANDLING UNIT SCHEDULE (AHU)

TAG	SERVICE	SUPPLY FAN DATA								COOLING COIL TAG(S)	HEATING COIL TAG(S)	FILTER % EFFICIENCY	FAN CIRCUIT			MANUFACTURER	MODEL	REMARKS	
		TOTAL CFM	MIN OA CFM	TSP (IN. W.C.)	ESP (IN. W.C.)	FAN TYPE	QTY	BHP	HP				OPERATING RPM	MERV	V/PH/Hz				MCA
AHU-6	2ND FLOOR PD	5425	1355	2.5	1.25	AIRFOIL	2	1.91	4	3223	CC-6	HC-6	8	208/3/60	22.5	30	DAIKIN	CAH012GMCC	ALL

- REMARKS:
- MULTIZONE AIR HANDLING UNIT WITH R-13 DOUBLE WALL CONSTRUCTION.
 - PROVIDE NEW MULTIZONE DAMPERS AND DAMPER ACTUATORS AND CONNECT TO EXISTING ZONED SUPPLY DUCTWORK WITH NEW FLEX CONNECTIONS AND DUCT TRANSITIONS. SIZE MULTIZONE DAMPERS PER AIRFLOWS LISTED ON THE DRAWINGS
 - RIGHT HAND COIL CONNECTIONS
 - LEFT HAND ACCESS DOORS
 - PROVIDE METAL SUPPORT STANDS TO ELEVATE AHU OFF FINISHED FLOOR AND PROVIDE ENOUGH HEIGHT TO PROPERLY TRAP CONDENSATE. AT A MINIMUM, STANDS SHALL BE PLACED AT EACH SHOP SPLIT AND LIFTING POINT ON THE AIR HANDLER FRAME
 - PROVIDE NEEDLEPOINT BIPOLAR IONIZATION FOR AIR-HANDLING UNITS (SIZED PER MANUFACTURER'S RECOMMENDATION) AND POWER OFF AHU FAN CIRCUIT. PROVIDE ANY TRANSFORMERS, WIRING, CONDUIT, ETC. FOR PROPER INSTALLATION
 - PROVIDE R/A SMOKE DETECTOR AND INTERLOCK FOR FAN SHUTDOWN AND INTERLOCK WITH FIRE ALARM SYSTEM
 - COORDINATE WITH EQUIPMENT SUPPLIER TO ENSURE AHU CAN BE BROKEN DOWN AND REASSEMBLED PROPERLY TO FIT THROUGH THE EXISTING DOORWAY.
 - SINGLE FAN CIRCUIT WITH REMOTE MOUNTED VARIABLE FREQUENCY DRIVE (VFD), VFD TO HAVE BACNET CONNECTION.

COOLING COIL SCHEDULE (CC)

TAG	LOCATION	CFM	TOTAL MBH	SENS. MBH	FACE AREA (SQ FT)	MAX FACE VEL (FPM)	ROWS	FPI	TUBE DIA. (IN.)	TUBE THICK. (IN.)	AIR DATA				FLUID DATA				MANUFACTURER	MODEL	REMARKS		
											EAT DB °F	LAT DB °F	WB °F	MAX PD (IN.)	FLUID	EWT (°F)	LWT (°F)	GPM				MAX WATER PD (FT.)	
CC-6	AHU-6	5425	219	151	10.77	505	6	10	0.625	0.02	80	67	54.5	53.9	0.75	WATER	45	55.1	43.4	14.9	DAIKIN	5WH1006B	ALL

- REMARKS:
- STAINLESS STEEL DRAIN PAN
 - TRAP CONDENSATE PER MANUFACTURERS INSTRUCTIONS
 - REFERENCE 3/M-3 FOR PIPING DETAIL

HEATING COIL SCHEDULE (HC)

TAG	LOCATION	TYPE	CFM	TOTAL BTUH	FACE AREA (SQ FT)	MAX FACE VEL (FPM)	ROWS	FPI	TUBE DIA. (IN.)	TUBE THICK. (IN.)	AIR DATA				FLUID DATA				MANUFACTURER	MODEL	REMARKS
											EAT DB °F	LAT DB °F	MAX PD (IN.)	EWT °F	LWT °F	FLUID	GPM	MAX PD (FT.)			
HC-6	AHU-6	HOT WATER	5,425	263	7.33	740	2	12	0.625	0.02	50.6	95.6	0.42	150	130	WATER	26	3.8	DAIKIN	5WH1202B	ALL

REMARKS:

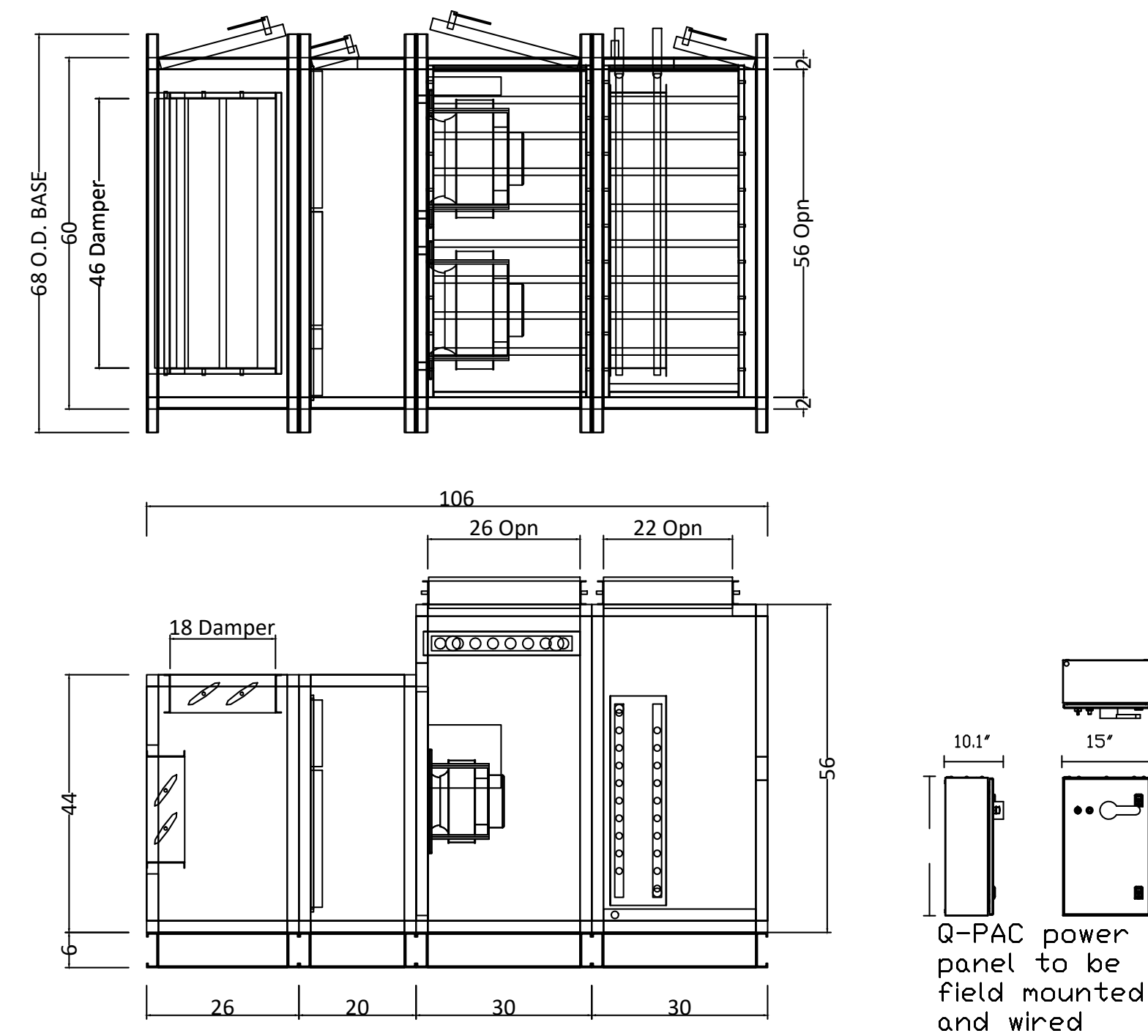

4 - AHU-6 DIMENSIONAL DRAWING

SCALE: 1/2" = 1'-0"

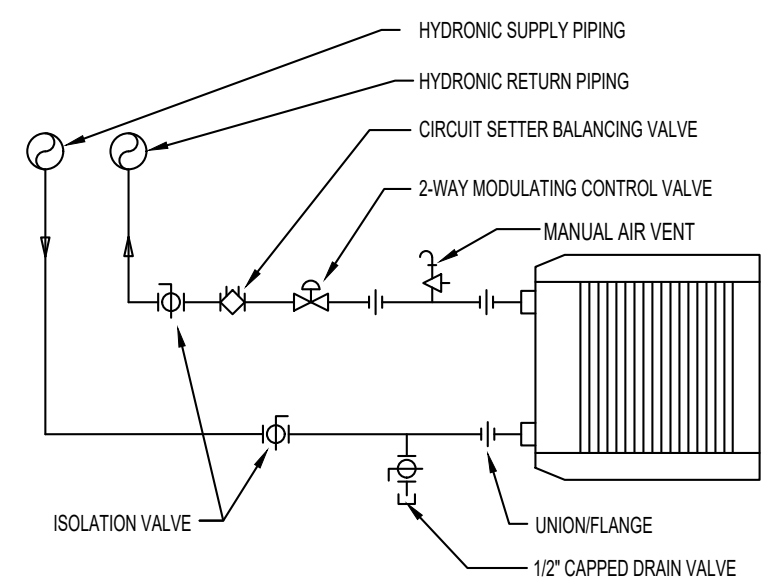

3 - CHW & HHW COIL DETAIL

SCALE: NTS = 1'-0"

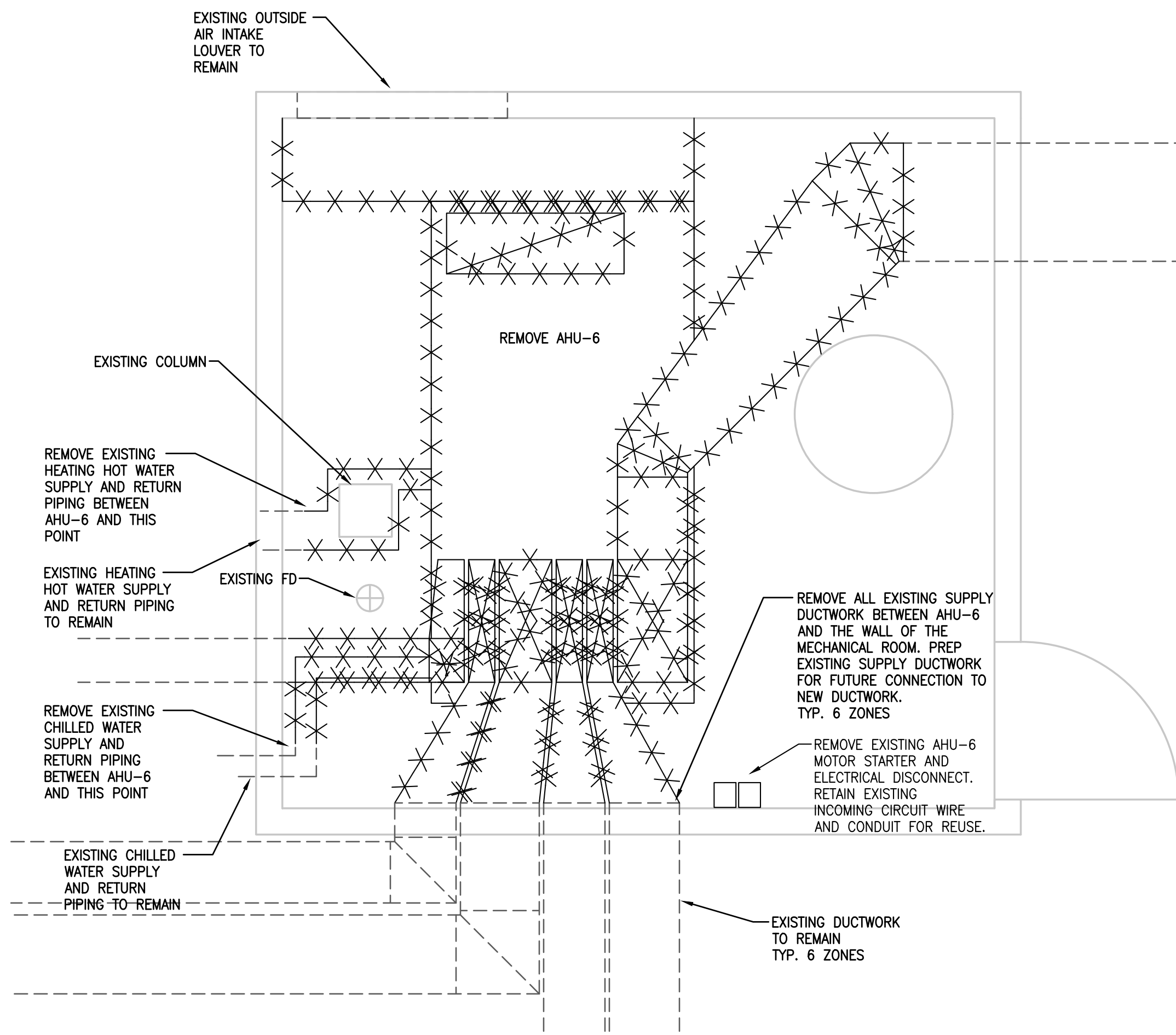

2 - AHU-6 DEMO PLAN

SCALE: 1/2" = 1'-0"

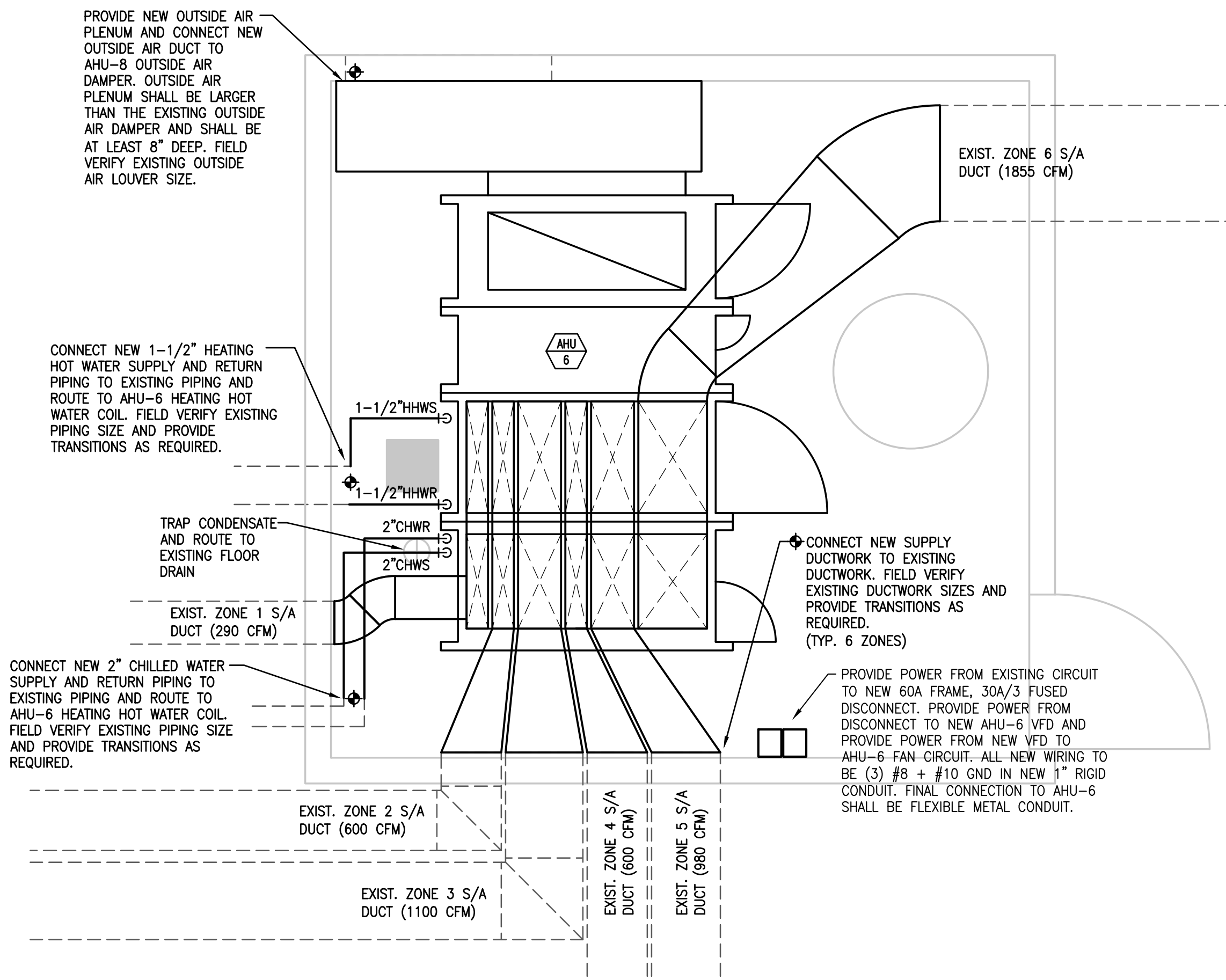

1 - AHU-6 HVAC PLAN

SCALE: 1/2" = 1'-0"

greenacorn
 1820 S. BOULDER AVE, #300
 TULSA, OKLAHOMA 74119
 918-629-4291
 GREEN ACORN LLC
 OK COA# 8292
 www.GreenAcornLLC.com

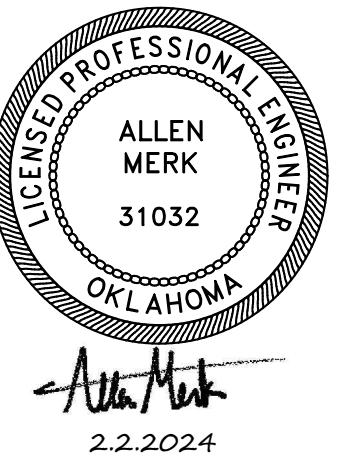

NO.	ISSUE LOG	DATE & INITIALS
1	95% REVIEW SET	1.18.24
2	ISSUED FOR BID	2.2.24

MIDWEST CITY CITY HALL
 HVAC UPGRADES - PHASE I

100 N MIDWEST BLVD
 MIDWEST CITY, OK 73110

AHU-6 PLANS & SCHEDULES

INITIAL DATE: 1-18-2024	JOB NO: 3024.01
DRAWN BY: AMM	CHECKED BY: KTM
PRINT DATE:	SHEET: M-3
	SHEET NO: 3 OF 6

FULL SIZE SHEET IS 34x22

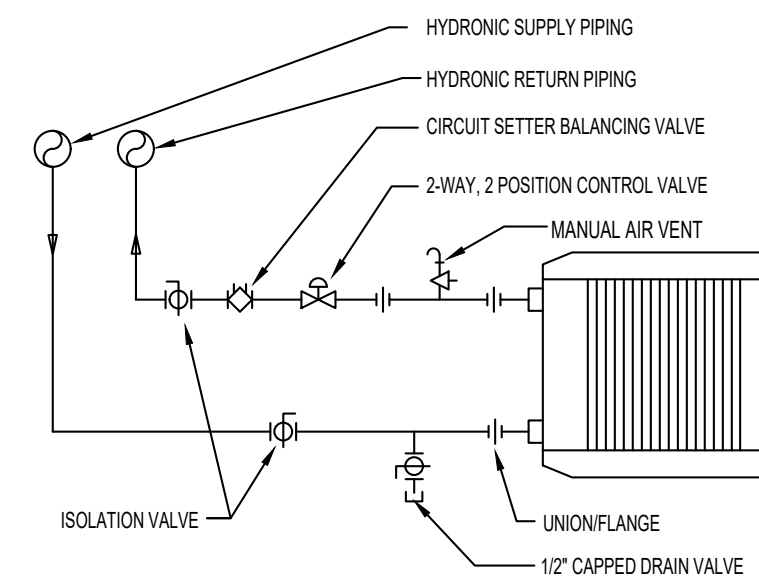

- NOTES:
1. PIPE SIZES 2-1/2" AND SMALLER SHALL HAVE FULL PORT BALL VALVES
 2. PIPE SIZES 3" AND LARGER SHALL HAVE FULL PORT BUTTERFLY VALVES

3 - CHW & HHW COIL DETAIL

SCALE: NTS = 1'-0"

FAN COIL UNIT SCHEDULE (FCU)

TAG	LOCATION	FAN DATA					HEATING COIL DATA										COOLING COIL DATA										MANUFACTURER	MODEL	REMARKS
		CFM	ESP (IN.)	RPM	HP	VOLTS/PH/Hz	MBH	ROWS	EAT DB °F	LAT DB °F	EWT °F	LWT °F	GPM	MAX PD (FT.)	TOTAL MBH	SENS. MBH	ROWS	EAT DB °F	EAT WB °F	LAT DB °F	LAT WB °F	EWT °F	LWT °F	GPM	MAX PD (FT.)				
FCU-1	BASEMENT	325	0.15	1050	1/20	120/1/60	11	1	70	102	150	130	1.1	4	8.5	7.2	4	73	61	52.4	51.4	45	55	1.8	7	SUPERIOR REX	RBHR-A-04	ALL	
FCU-2	BASEMENT	500	0.15	1140	1/10	120/1/60	18	1	70	102	150	130	1.8	16	13.3	11.5	4	74	61	52.9	51.7	45	55	2.8	6	SUPERIOR REX	RBHR-A-06	ALL	

REMARKS:

1. DIRECT DRIVE FAN COIL UNIT CONSTRUCTED OF GALVANIZED STEEL PANELS AND INSULATED WITH 3/8" THICK ELASTOMERIC CLOSED CELL FOAM INSULATION (MEETING NFPA 90A FLAME/SMOKE SPREAD REQUIREMENTS & 24/50 FLAME/SMOKE INDEX PER ASTM E-84 OR UL 723) WITH DUCT COLLAR ON THE DISCHARGE AND UNIT MOUNTED HANGER BRACKETS. 3-SPEED (OR VARIABLE SPEED) MOTOR WITH THERMAL OVERLOAD PROTECTION. CHILLED WATER AND HEATING HOT WATER COILS SHALL BE COPPER WITH ALUMINUM FINNS AND SHALL HAVE THE HOT WATER COIL IN THE REHEAT POSITION. DRAIN PANS SHALL BE ONE-PIECE GALVANIZED CONSTRUCTION AND SHALL EXTEND UNDER THE ENTIRE COOLING COIL AND INSULATED WITH CLOSED CELL INSULATION MEETING 25/50 ASTM E-84 AND UL 723 FLAME/SMOKE SPREAD RATING. UNITS SHALL BE EQUIPPED WITH A 1" FILTER RACK WITH FILTER REMOVAL FROM THE BOTTOM OF THE UNIT. UNITS SHALL BE FURNISHED WITH SINGLE POINT POWER CONNECTION WITH ELECTRICAL JUNCTION BOX W/ TOGGLE SWITCH DISCONNECT FOR MOTOR AND OTHER ELECTRICAL TERMINATIONS AND SHALL BE ABLE TO BE ACCESSED/SERVED FROM THE BOTTOM.
2. PROVIDE NEW THERMOSTAT IN EXISTING THERMOSTAT LOCATION
3. FIELD VERIFY ELECTRICAL VOLTAGE PRIOR TO ORDERING FCU'S
4. PROVIDE CONDENSATE OVERFLOW SWITCH WIRED FOR FAN SHUTDOWN

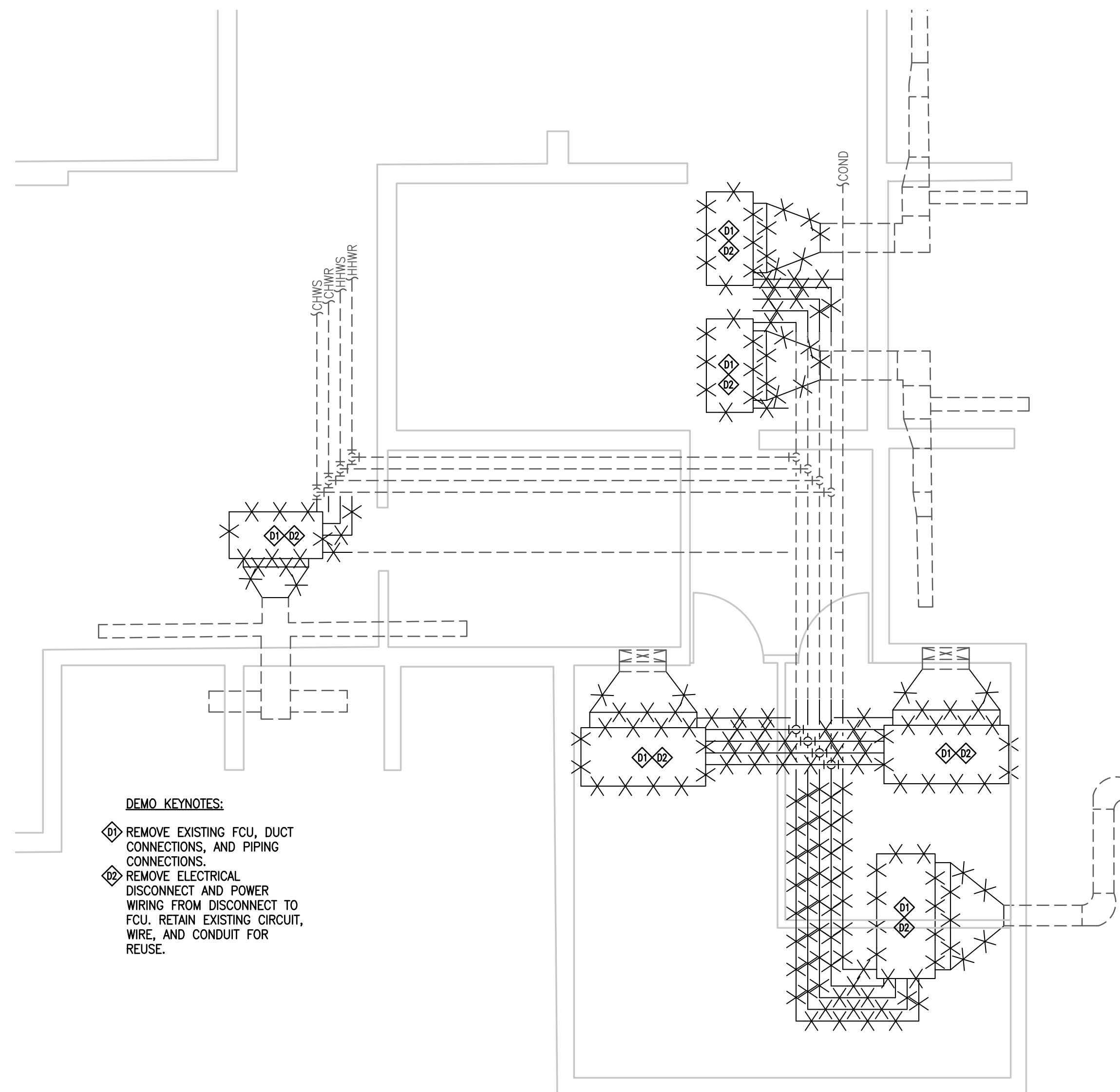

DEMO KEYNOTES:

- ⓧ REMOVE EXISTING FCU, DUCT CONNECTIONS, AND PIPING CONNECTIONS.
- ⓧ REMOVE ELECTRICAL DISCONNECT AND POWER WIRING FROM DISCONNECT TO FCU. RETAIN EXISTING CIRCUIT, WIRE, AND CONDUIT FOR REUSE.

2 - BASEMENT MECH DEMO PLAN

SCALE: 1/4" = 1'-0"

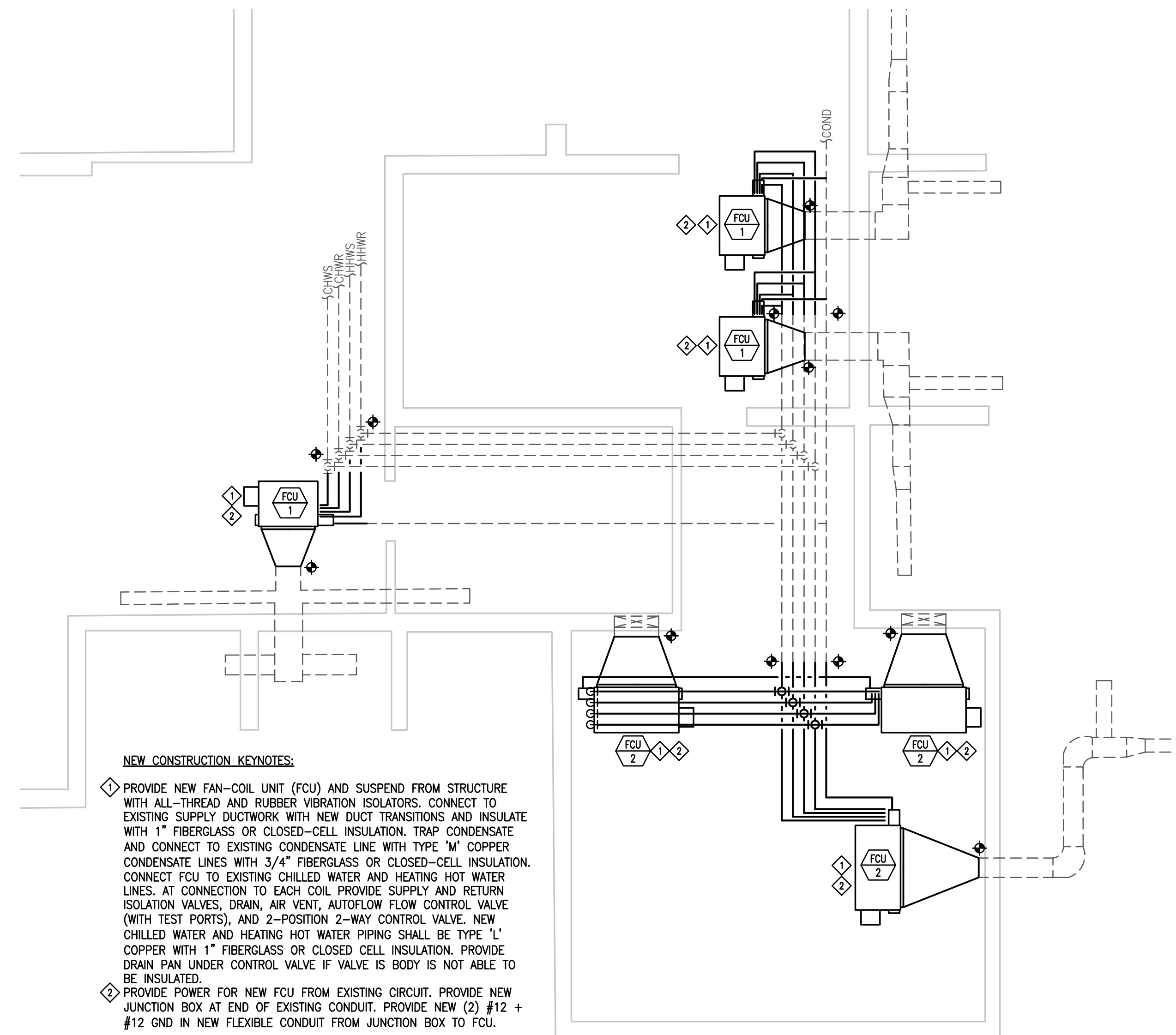

NEW CONSTRUCTION KEYNOTES:

- ⓧ PROVIDE NEW FAN-COIL UNIT (FCU) AND SUSPEND FROM STRUCTURE WITH ALL-THREAD AND RUBBER VIBRATION ISOLATORS. CONNECT TO EXISTING SUPPLY DUCTWORK WITH NEW DUCT TRANSITIONS AND INSULATE WITH 1" FIBERGLASS OR CLOSED-CELL INSULATION. TRAP CONDENSATE AND CONNECT TO EXISTING CONDENSATE LINE WITH TYPE 'M' COPPER CONDENSATE LINES WITH 3/4" FIBERGLASS OR CLOSED-CELL INSULATION. CONNECT FCU TO EXISTING CHILLED WATER AND HEATING HOT WATER LINES. AT CONNECTION TO EACH COIL PROVIDE SUPPLY AND RETURN ISOLATION VALVES, DRAIN, AIR VENT, AUTOFLOW FLOW CONTROL VALVE (WITH TEST PORTS), AND 2-POSITION 2-WAY CONTROL VALVE. NEW CHILLED WATER AND HEATING HOT WATER PIPING SHALL BE TYPE 'L' COPPER WITH 1" FIBERGLASS OR CLOSED CELL INSULATION. PROVIDE DRAIN PAN UNDER CONTROL VALVE IF VALVE IS BODY IS NOT ABLE TO BE INSULATED.
- ⓧ PROVIDE POWER FOR NEW FCU FROM EXISTING CIRCUIT. PROVIDE NEW JUNCTION BOX AT END OF EXISTING CONDUIT. PROVIDE NEW (2) #12 + #12 GND IN NEW FLEXIBLE CONDUIT FROM JUNCTION BOX TO FCU.

1 - BASEMENT MECHANICAL PLAN

SCALE: 1/4" = 1'-0"



greenacorn

1820 S. BOULDER AVE, #300
TULSA, OKLAHOMA 74119
918-629-4291

GREEN ACORN LLC
OK COA# 8292
www.GreenAcornLLC.com



NO.	ISSUE LOG	DATE & INITIALS
1	95% REVIEW SET	1.18.24
2	ISSUED FOR BID	2.2.24

MIDWEST CITY
CITY HALL
HVAC UPGRADES - PHASE I

100 N MIDWEST BLVD
MIDWEST CITY, OK 73110

FCU PLANS
& SCHEDULES

INITIAL DATE: 1-18-2024	JOB NO: 3024.01
----------------------------	--------------------

DRAWN BY: AMM	CHECKED BY: KTM	SHEET: M-4
------------------	--------------------	----------------------

PRINT DATE:	SHEET NO: 4 OF 6
-------------	---------------------

FULL SIZE SHEET IS 34x22

PUMP SCHEDULE

TAG	MFR.	MODEL	TYPE	GPM	DISCH. HEAD (FT.W.G.)	NPSH	ELEC. DATA				PIPE CONN.		UNIT WT (LB)	REMARKS
							HP	RPM	VOLT	PH	INLET	OUTLET		
HHWP-1	GRUNDFOS	LCS 25957	BASE MOUNTED END SUCTION	245	65	4.43	5	1775	208	3	3	2.5	275	ALL
CHWP-1	GRUNDFOS	LCS 30957	BASE MOUNTED END SUCTION	395	70	4.21	10	1775	208	3	4	3	300	ALL

REMARKS:

1. PROVIDE NEW 4" CONCRETE PAD FOR PUMP, SECURE PUMP TO PAD, AND GROUT PUMP BASE TO PAD
2. PROVIDE PUMP ACCESSORIES AND INSTALL PER BASE MOUNTED PUMP DETAIL
3. PROVIDE VARIABLE FREQUENCY DRIVE WITH INTEGRAL DISCONNECT AND BACNET CARD. PROVIDE VFD STARTUP BY FACTORY AUTHORIZED PERSONEL

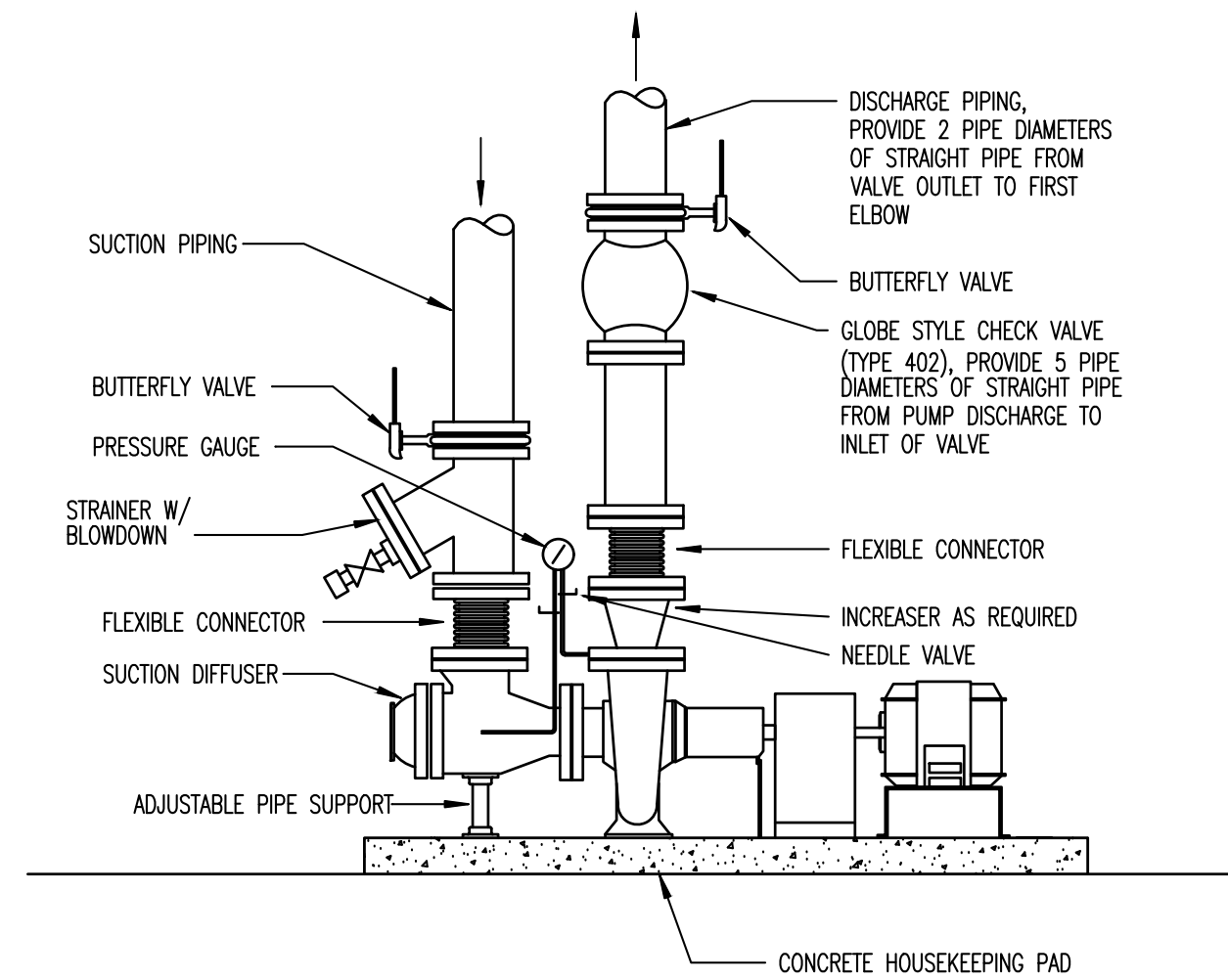

3 - BASE MOUNTED PUMP DETAIL

SCALE: NTS

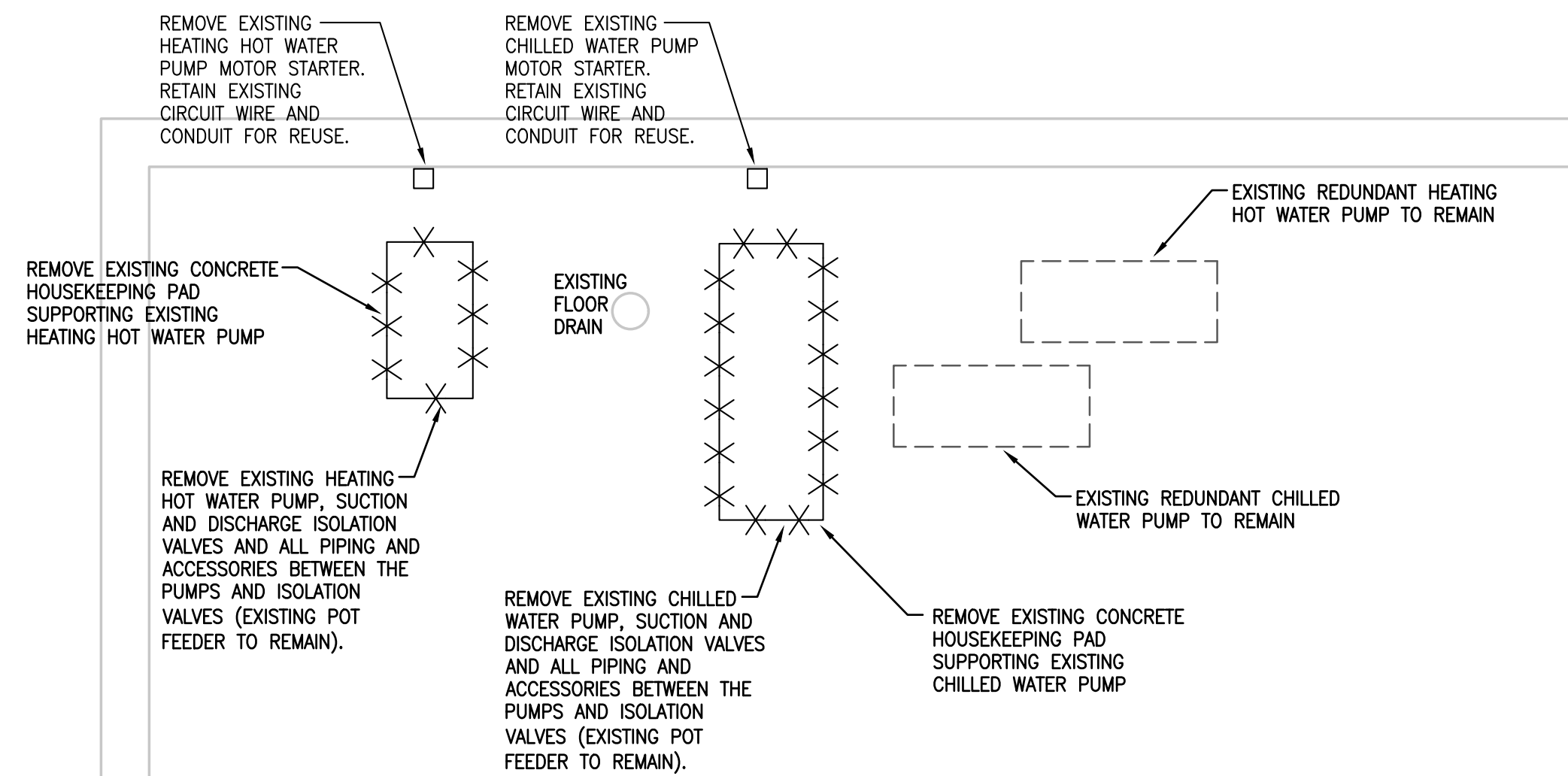

2 - PUMP DEMO PLAN

SCALE: 1/2" = 1'-0"

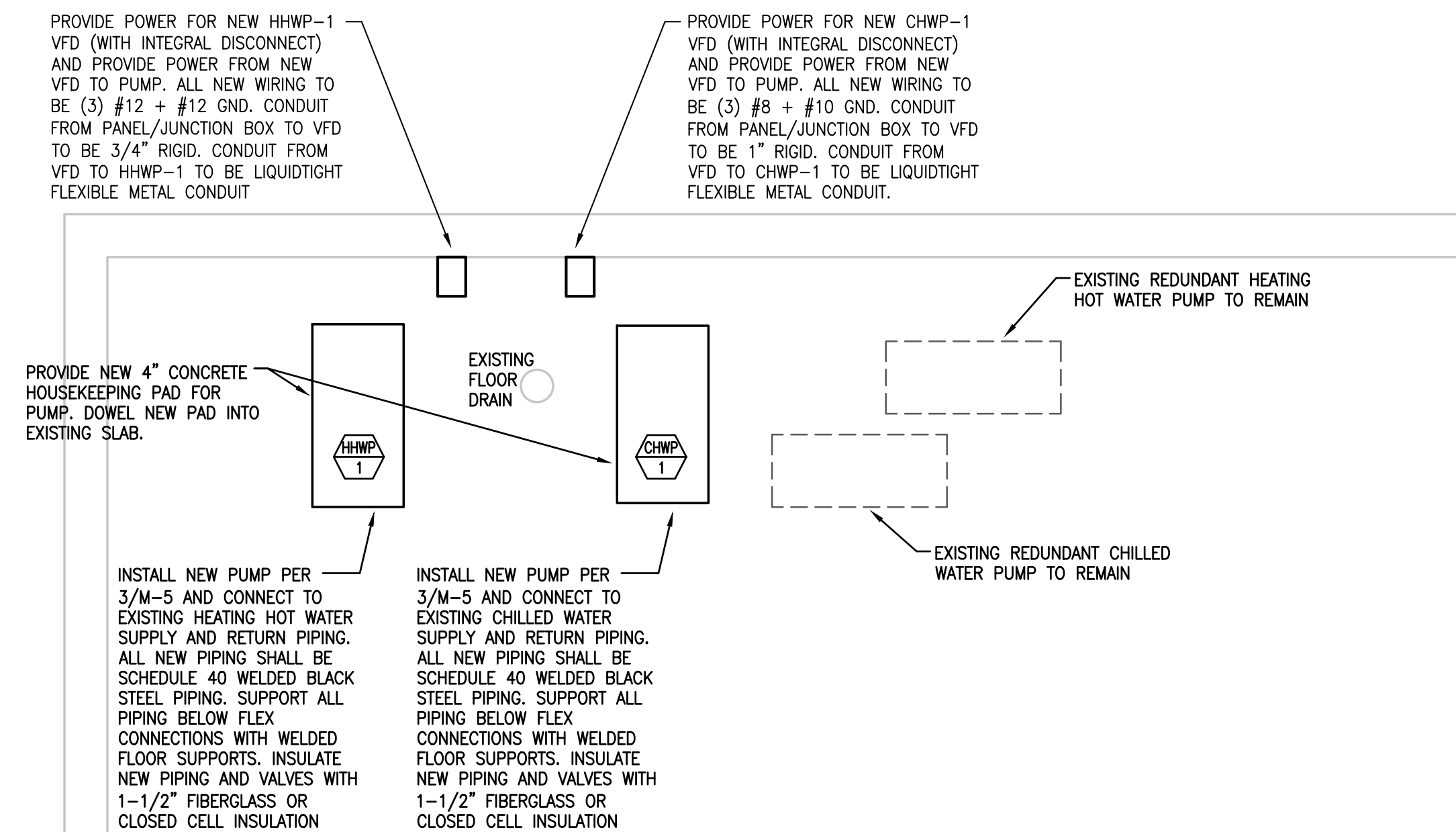

1 - PUMP PLAN

SCALE: 1/2" = 1'-0"



greenacorn

1820 S. BOULDER AVE, #300
TULSA, OKLAHOMA 74119
918-629-4291

GREEN ACORN LLC
OK COA# 8292
www.GreenAcornLLC.com



Allen Merk
2.2.2024

NO.	ISSUE LOG	DATE & INITIALS
1	95% REVIEW SET	1.18.24
2	ISSUED FOR BID	2.2.24

**MIDWEST CITY
CITY HALL**
HVAC UPGRADES - PHASE I

100 N MIDWEST BLVD
MIDWEST CITY, OK 73110

CHWP & HHWP
PLANS & SCHEDULES

INITIAL DATE: 1-18-2024
JOB NO: 3024.01

DRAWN BY: AMM
CHECKED BY: KTM
SHEET: M-5

PRINT DATE: SHEET NO: 5 OF 6

FULL SIZE SHEET IS 34x22

CONSTRUCTION SERVICES AGREEMENT
between
(Service Provider Name)
And
THE CITY OF MIDWEST CITY

THIS CONSTRUCTION SERVICES AGREEMENT (hereinafter referred to as “**Agreement**”) is entered into by and among The City of Midwest City, a municipal corporation (hereinafter referred to as “**City**”), and (SERVICE PROVIDER NAME), (hereinafter referred to as “**Service Provider**”) (**City**, and **Service Provider** being collectively referred to herein as the “**Parties**”) and is effective upon the date of execution by the last party hereto.

WITNESSETH:

WHEREAS, **City** is in need of the following construction services for 100 N MIDWEST BLVD, REPLACEMENT OF AHU 6&8; and

WHEREAS, **Service Provider** is in the business of providing construction services that is needed by the **City**; and

WHEREAS, the **City** and the **Service Provider** have reached an agreement for the **Service Provider** to provide the **City** the requested construction services; and

WHEREAS, **City** hereby retains **Service Provider** to provide construction services as an independent contractor; and

WHEREAS, **Service Provider** agrees to provide the **City** all services, in accordance with the standards exercised by experts in the field, necessary to provide the **City** services, products, solutions and deliverables that meet all the purposes and functionality requested or described in the RFP and in this Agreement.

NOW, THEREFORE, for and in consideration of the above premises and mutual covenants as set forth herein, the **City**, and **Service Provider** hereby agree as follows:

1. INDEPENDENT CONTRACTOR STATUS

Subject to the terms and conditions of this Agreement, the **City** retains the **Service Provider** as an independent contractor, to provide **City** all services, in accordance with the standards exercised by experts in the field, necessary to provide the **City** services, products,

CONSTRUCTION SERVICES AGREEMENT
between
(Service Provider Name)
And
THE CITY OF MIDWEST CITY

solutions, and deliverables (collectively referred to as “Deliverables”) that meet all the purposes and functionality requested or described in this Agreement. The **City** shall meet with **Service Provider** to identify service needs on a project by project basis. **Service Provider** will provide a written proposal for the identified services in accord with the terms and conditions of this Agreement. The **City** may issue a purchase order for the identified services accompanied by **Service Provider’s** written proposal. Upon issuance of the purchase order, the **Service Provider** shall be responsible for timely providing the services authorized by the purchase order (“Project”). Upon completion of the Project (services in a purchase order), the **Service Provider** will issue an invoice to the **City** and, upon approval of the invoice, the **City** will pay the invoice. Upon completion of each Project and provision to the **City** of all Deliverables for that Project and payment of the invoice for that Project to the **Service Provider**, the **City** shall own all rights and license for the Deliverables and other work products related to that Project.

a) This Agreement governs the Scope of Services including, but not limited to, all Deliverables to be provided by **Service Provider** to the **City**. The Attachments are incorporated into this Agreement by reference and, should there be a conflict in language, terms, conditions, or provisions, shall have the priority and precedential value as set forth in this Agreement.

b) The text of this Agreement together with the Attachments constitutes the entire Agreement and the only understanding and agreement between the **City** and the **Service Provider** with respect to the services, products, solutions and deliverables to be provided by the **Service Provider** hereunder. This Agreement may only be amended, modified or changed in writing when signed by all parties, or their respective specifically authorized representatives, as set forth in this Agreement.

c) If there is a conflict in language, terms, conditions, or provisions, in this Agreement

CONSTRUCTION SERVICES AGREEMENT
between
(Service Provider Name)
And
THE CITY OF MIDWEST CITY

between the text of this document, and any language, term, condition, or provision in any Attachment, then the text of this document, shall govern and control over any conflicting language, term, condition, or provision in any Attachment. As among the Attachments any conflict in the language, terms, conditions, or provisions shall be governed in the following order of priority and precedence:

- Attachment “A” (“Scope of Services”)
- Attachment “B” (“Schedule of Fees / Rate Card”),
- Attachment “C” (“**Service Provider’s Team**”),
- Attachment “D” (“Insurance”).

2. RETENTION OF SERVICES PROVIDER AND SCOPE OF SERVICES

A. **Service Provider** is solely responsible for the actions, non-action, omissions, and performance of **Service Provider’s** employees, agents, contractors, and subcontractors (herein collectively included in the term “Service Provider’s Project Team”) and to ensure the timely provision of each Project, timely performance of the Scope of Services, and the timely performance of each Project and the provision of all Deliverables as each are defined in **Attachment “A” (“Scope of Services”)** or the Project.

B. **Service Provider** will be solely responsible to ensure the **Service Provider’s Project Team** fully understands each Project, the Scope of Services, the Deliverables, the schedule for performance, and **City’s** goals and purposes. Service Provider will be solely responsible to ensure the **Service Provider’s Team**, specifically assigned to work on the Project for the City, is adequately trained, instructed, and managed so that **Service Provider** timely provides each Project task and satisfies the **Service Provider’s** obligations under this Agreement. The **Service Provider** may not change the **Service Provider’s Team**, for the services to be provided as set forth on Attachment “C” (“**Service Provider’s Team**”) without the prior written consent of the **City**.

CONSTRUCTION SERVICES AGREEMENT
between
(Service Provider Name)
And
THE CITY OF MIDWEST CITY

C. **Service Provider** shall comply with all applicable federal, state and local laws, standards, codes, ordinances, administrative regulations and all amendments and additions thereto, pertaining in any manner to the performance or services provided under this **Agreement**. **Service Provider** shall obtain all patents, licenses and any other permission required to provide all Deliverables and for use of all Deliverables by the **City**.

3. CONSIDERATION

A. The **City** shall pay the **Service Provider** the compensation after completion of Projects or Deliverables as specified in **Attachment “B” (“Schedule of Fees / Rate Card”)**.

B. The **City** and the **Service Provider** acknowledge that the compensation to be paid the **Service Provider** pursuant to this **Agreement** has been established at an amount reasonable for the availability and services of the **Service Provider and the Service Provider’s Team**.

4. INDEPENDENT CONTRACTOR STATUS

The parties hereby acknowledge and covenant that:

A. **Service Provider** is an independent contractor and will act exclusively as an independent contractor is not an agent or employee of the **City** in performing the duties in this Agreement.

1. The parties do not intend, and will not hold out that there exists, any corporation, joint venture, undertaking for a profit or other form of business venture or any employment relationship among the parties other than that of an independent contractor relationship.

2. All payments to **Service Provider** pursuant to this **Agreement** shall be due and payable in the State of Oklahoma, even if services of **Service Provider** are performed outside the State of Oklahoma.

B. The **City** shall not withhold any social security tax, workmen’s compensation, Medicare tax, federal unemployment tax, federal income tax, or state income tax from any compensation paid to **Service Provider** as **Service Provider** is an independent contractor and

CONSTRUCTION SERVICES AGREEMENT
between
(Service Provider Name)
And
THE CITY OF MIDWEST CITY

the members of its **Service Provider’s Team**, assigned to work on the Project for the **City** are not employees of the **City**. Any such taxes, if due, are the responsibilities of **Service Provider** and will not be charged to the **City**.

C. **Service Provider** acknowledges that as an independent contractor it and **Service Provider’s Project Team**, assigned to work on the Project for the **City** are not eligible to participate in any health, welfare or retirement benefit programs provided by the **City** or its employees.

5. TERM, TERMINATION AND STOP WORK

A. This **Agreement** shall commence upon execution by the last party hereto and shall continue in effect for one-year from the date of execution, unless terminated by either party as provided for herein. This **Agreement** may be extended by mutual agreement of the **Parties** in one-year increments, until the Project is completed and accepted as provided herein.

B. The **City** issue notices of termination or suspension to the **Service Provider**. This **Agreement** may be terminated, with or without cause, upon written notice, at the option of **City**.

1. Upon receipt of a notice of termination for the *convenience* from the **City**, the **Service Provider** shall immediately discontinue all services and activities (unless the notice directs otherwise), and

2. Upon payment for products or services fully performed and accepted, **Service Provider** shall deliver to the **City** all licenses, work, products, deliverables, solutions, communication recommendations, plans, messaging strategies, style guides, design elements, internal and external messaging campaigns, documents, data analysis, reports, and other information and materials accumulated or created in performing this **Agreement**, whether same are complete or incomplete, unless the notice directs otherwise. Upon termination for the *convenience* by the **City**, the **City** shall pay **Service Provider** for completed Projects and Deliverables up to the time of the notice of termination for *convenience*, in accordance with the

CONSTRUCTION SERVICES AGREEMENT
between
(Service Provider Name)
And
THE CITY OF MIDWEST CITY

terms, limits and conditions of the **Agreement** and as further limited by the “not to exceed” amounts set out in this **Agreement**.

3. Upon notice of termination for *cause* from the **City**, the **Service Provider** shall not be entitled to any prior or future payments, including, but not limited to, any services, performances, work, products, deliverables, solutions, costs, or expenses, and **Service Provider** shall release and waive any interest in any retainage. The **City** may hold any outstanding payments for prior completed Projects, Deliverables, Services or expenses and any retainage as security for payment of any costs, expenses, or damages incurred by the **City** by reason of **Service Provider’s** breach or other cause. Provided, however, upon notice of termination for cause, the **Service Provider** shall deliver to the **City** services, products, solutions, and Deliverables including, but limited to, all communication recommendations, plans, messaging strategies, style guides, design elements, internal and external messaging campaigns, documents, data analysis, reports, and other information and materials accumulated or created in performing this **Agreement**, whether complete or incomplete, unless the notice directs otherwise.

4. The rights and remedies of the **City** provided in this paragraph are in addition to any other rights and remedies provided by law or under the **Agreement**. Termination herein shall not terminate or suspend any warranty, indemnification, insurance, or confidentiality required to be provided by **Service Provider** under this **Agreement**.

C. Upon notice to **Service Provider**, the **City** may issue a stop work order suspending any Projects, services, performances, work, products, Deliverables, or solutions under this **Agreement**. Any stop work order shall not terminate or suspend any warranty, indemnification, insurance, or confidentiality required to be provided by **Service Provider** under this **Agreement**. In the event the **City** issues a stop work order to **Service Provider**, the **City** will provide a copy of such stop work order to the **Service Provider**. Upon receipt of a stop work order issued from the **City**, the **Service Provider** shall suspend all work, services and activities except such

CONSTRUCTION SERVICES AGREEMENT
between
(Service Provider Name)
And
THE CITY OF MIDWEST CITY

work, services, and activities expressly directed by the **City** in the stop work order. Upon notice to the **Service Provider**, this **Agreement**, and any or all work, services, and activities thereunder, may be suspended up to thirty (30) calendar days by the **City**, without cause and without cost to the **City**; provided however, the **Service Provider** shall be entitled to an extension of all subsequent deadlines for a period equal to the suspension periods for those suspended work, services, and activities only.

D. Obligation upon Termination for *Convenience*.

1. In the event this **Agreement** is terminated for convenience hereunder, the **City** shall pay **Service Provider** for such properly documented invoices, if any, in accordance with the provisions of this **Agreement** above, through the date of termination for *convenience* and the period set forth in the notice, and thereafter the **City** shall have no further liability under this **Agreement** to **Service Provider** and **Service Provider** shall have no further obligations to the **City**.

2. Upon termination for *convenience* of the Project and the providing to the **City** of all Deliverables for the Project and payment of the invoice for the Project to **Service Provider**, the **City** shall own all rights and license for the Deliverables and other work products related to that Project.

6. WARRANTIES

A. **Service Provider** warrants that the Projects performed and Deliverables provided under this **Agreement** shall be performed consistent with generally prevailing professional standards and expertise. **Service Provider** shall maintain during the course of this **Agreement** said standard of care, expertise, skill, diligence and professional competency for any and all such services, products, solutions and deliverables. **Service Provider** agrees to require all members of the **Service Provider's Team**, also including FTEs assigned to work on the Project, to provide any and all services, products, solutions and Deliverables at said same standard of care, expertise, skill, diligence and professional competence required of **Service Provider**.

CONSTRUCTION SERVICES AGREEMENT
between
(Service Provider Name)
And
THE CITY OF MIDWEST CITY

B. During the term of this **Agreement**, the **City's** initial remedy for any breach of the above warranty shall be to permit **Service Provider** one additional opportunity to perform the work, services, and activities or provide the Projects and Deliverables without additional cost to the **City**. If the **Services Provider** cannot perform the work, services, and activities or provide the products, solutions and deliverables according to the standards and requirements set forth in this **Agreement** within thirty (30) calendar days of the original performance date, the **City** shall be entitled to recover, should the **City** so determine to be in their best interest, any fees paid to the **Service Provider** for previous payments, including, but not limited to, work, services, activities services, Projects and Deliverables and **Service Provider** shall make reimbursement or repayment within thirty (30) calendar days of a demand by the **City**. Should the **Service Provider** fail to reimburse the **City** within thirty (30) calendar days of demand, the **City** shall also be entitled to interest at 1.5% percent per month on all outstanding reimbursement and repayment obligations.

C. The **Service Provider** also acknowledges and agrees to provide all express and implied, warrants required or provided for by Oklahoma statutory and case law. This warrant is in addition to other warranties provided in or applicable to this **Agreement** and may not be waived by any other provision, expressed or implied, in this **Agreement** or in any **Attachment** hereto.

7. INSURANCE

A. **Service Provider** must provide and maintain at all times throughout the term of this **Agreement**, and any renewal hereof, such *commercial general insurance with a limit of \$1,000,000 per occurrence for bodily injury and property damage and \$5,000,000 general aggregate* protecting the **City** from claims for bodily injury (*including death*) and or property damage arising out of or resulting from the **Service Provider**, and its employees, use and occupancy of the premises and the activities conducted thereon . The insurance coverage required in this paragraph must include the **City** as additional insureds as their interest may appear under

CONSTRUCTION SERVICES AGREEMENT
between
(Service Provider Name)
And
THE CITY OF MIDWEST CITY

this **Agreement** under the policy or policies.

B. A certificate of insurance evidencing the coverage required herein shall be provided to the **City** within five (5) days of the execution of this **Agreement**.

C. **Service Provider** shall require any contractor or subcontractor to obtain and maintain substantially the same coverage as required of **Service Provider** including the **City** as an additional insured as their interest may appear under this **Agreement**.

D. The insurance requirements set forth herein must not be deemed to limit, affect, waive, or define any obligations of the **Service Provider** in any other paragraph of this **Agreement** or any indemnification or insurance requirement in any other paragraph of this **Agreement**. This paragraph must continue in full force and affect for any act, omission, incident or occurrence occurring or commencing during the term of this **Agreement**. Further, the insurance coverage required by this paragraph will survive revocation, non-renewal, termination and expiration of this **Agreement** for any occurrence or event occurring, initiated, or commencing prior to such revocation, non-renewal, termination and expiration or during the period in which the **Service Provider** is services under the **Agreement**.

E. Provided, however, should the **Service Provider** or its officers, invitees, representatives, contractors, employees or agents carry any additional, different or other insurance or insurance coverage of any kind or nature, the provisions of this paragraph must not in any way limit, waive or inhibit the **City** from making a claim or recovering under such insurance or insurance coverage.

F. Notwithstanding any other provision to the contrary, upon termination or lapse of insurance coverage required hereunder, this **Agreement** may be terminated. Termination of this **Agreement** pursuant to this paragraph must take precedence and supersede any other paragraph establishing the term of this **Agreement**, establishing a procedure for revocation or termination, or requiring notice and/or providing an opportunity to cure a breach.

G. The insurance limits in this paragraph in no way act or will be deemed to define or limit the right of **City** to recover damages, expenses, losses or for personal injuries, death or

CONSTRUCTION SERVICES AGREEMENT
between
(Service Provider Name)
And
THE CITY OF MIDWEST CITY

property damage pursuant to applicable law or the indemnification provisions or under any other paragraph or provision in this **Agreement**.

8. INDEMNIFICATION

A. **Service Provider** agrees to indemnify, defend, and hold harmless the **City** from and against all liability for: (a) injuries or death to persons; (b) costs, losses, and expenses; (c) legal fees, legal expenses, and court costs; and (d) damages, loss to property, which are caused by the **Service Provider**, its officers, representatives, agents, contractors, and employees except to the extent such injuries, losses, damages and/or costs are caused by the negligence or willful misconduct of the indemnified party. The **Service Provider** must give the **City** prompt and timely notice of any claim or suit instituted which in any way, directly or indirectly, contingently or otherwise, affects or might affect the **City**, provided, however, such notice will not be a precondition to indemnification hereunder. The rights granted by this paragraph will not limit, restrict, or inhibit the rights of the **City** under any other paragraph, including but not limited to any insurance provision or requirement in this **Agreement**.

B. The provisions of this paragraph shall survive the expiration of this **Agreement**. It is understood that these indemnities and hold harmless provisions are not limited or defined by the insurance required under the insurance provisions of this **Agreement**.

9. CONFIDENTIALITY

Service Provider acknowledges that in the course of training and providing other services to the **City**, the **City** may provide **Service Provider** with access to valuable information of a confidential and proprietary nature including but not limited to information relating to the **City's** employees, customers, marketing strategies, business processes and strategies, security systems, data and technology. **Service Provider** agrees that during the time period this **Agreement** is in effect, and thereafter, neither **Service Provider** nor **Service Provider's Team**, without the prior written consent of the **City**, shall disclose to any person, other than to the **City**, any

CONSTRUCTION SERVICES AGREEMENT
between
(Service Provider Name)
And
THE CITY OF MIDWEST CITY

information obtained by **Service Provider**. **Service Provider** shall require and maintain adequate confidentiality agreements with its employees, agents, contractors, and subcontractors.

10. NOTICES

A. Notices and other communications to the **City** pursuant to the provisions hereof will be sufficient if sent by first class mail, postage prepaid, return receipt required, or by a nationally recognized courier service, addressed to:

The City of Midwest City, City Clerk
100 N. Midwest Boulevard
Midwest City, OK 73110

respectively, and notices or other communications to the **Service Provider** pursuant to the provisions hereof will be sufficient if by first class mail, postage prepaid, return receipt required, or by a nationally recognized courier service, addressed to:

(Contact Person name for Service Provider)

(Name of Service Provider)

(street or mailing address for service provider)

(City, State and zip code for service provider)

B. Any party hereto may change the address or addressee for the giving of notice to it by thirty (30) days prior written notice to the other parties hereto as provided herein. Unless otherwise specified in this **Agreement**, notice will be effective upon actual receipt or refusal as shown on the receipt obtained pursuant to this paragraph.

11. ABIDES BY LAW

The **Service Provider** must abide by the conditions of this **Agreement**, the ordinances of the **City**, and all laws and regulations of the State of Oklahoma and the United States of America (“Laws”), applicable to **Service Provider’s** activities. **Service Provider** will be responsible for

CONSTRUCTION SERVICES AGREEMENT
between
(Service Provider Name)
And
THE CITY OF MIDWEST CITY

securing any license, permits and/or zoning which may be required prior to commencement of the Project.

12. ASSIGNMENT AND SUBLEASE

Service Provider may not assign or sublease its interest under this **Agreement** without the prior written consent of the **City**. Any assignment or sublease shall become effective upon receipt of a request signed by authorized and empowered officers/agents of the **Service Provider** and sublessee and provision by the sublessee of a certificate of insurance evidencing the insurance required by this **Agreement** and upon approval of such sublease by **City**. The **City** may, but not required, to execute a letter approving either the assignment or sublease as provided herein on behalf of **City**. Upon approval of such assignment or sublease, **Service Provider** will not be relieved of future performance, liabilities, and obligations under this **Agreement**. **City** shall be provided with a copy of each written sublease agreement, and all amendments thereto, entered into by **Service Provider** within forty-five (45) days after the entering into of same.

13. COMPLETE AGREEMENT AND AMENDMENT

This is the complete agreement between the parties and no additions, amendments, alterations, or changes in this **Agreement** shall be effective unless reduced to writing and signed by all parties hereto. Additionally, no statements, discussions, or negotiations shall be deemed or interpreted to be included in this **Agreement**, unless specifically and expressly provided herein.

14. TIME OF ESSENCE

For the purposes of this **Agreement**, time shall be deemed to be of the essence.

15. MULTIPLE ORIGINALS

This **Agreement** shall be executed in multiple counterparts, each of which shall be deemed an original.

CONSTRUCTION SERVICES AGREEMENT
between
(Service Provider Name)
And
THE CITY OF MIDWEST CITY

16. ANTI-COLLUSION

Service Provider agrees that it has not been and shall not be a party to any collusion with any of their officials, trustees, or employees of the **City** as to the terms or conditions of this **Agreement**, and has not and will not exchange, give or donate money or other things of value for special consideration to any officials, trustees, or employees of the **City**, either directly or indirectly, in procuring and execution of this **Agreement**.

17. BREACH AND DEFAULT

A. A breach of any provision of this **Agreement** shall act as a breach of the entire **Agreement** unless said breach is expressly waived in writing by all other parties hereto. Failure to enforce or timely pursue any breach shall not be deemed a waiver of that breach or any subsequent breach. No waiver of any breach by any party hereto of any terms, covenants, or conditions herein contained shall be deemed a waiver of any subsequent breach of the same, similar, or different nature.

B. Further, except as otherwise specifically and expressly provided and any other paragraph hereto, should any party hereto fail to perform, keep or observe any of the terms, covenants, or conditions herein contained, this **Agreement** may be terminated by any party not in default thirty (30) days after receipt of written notice and opportunity to cure, less and except as such lesser time is provided in this **Lease**.

C. Should the **City** breach this **Agreement**, **Service Provider** may only recover that proportion of services provided prior to the breach. **Service Provider** may not collect or recover any other or additional damages, losses, or expenses.

18. THIRD PARTY BENEFICIARIES

All parties expressly agree that no third-party beneficiaries, expressly or implicitly, are intended to be or shall be created or acknowledged by this **Agreement**. This **Agreement** is solely

CONSTRUCTION SERVICES AGREEMENT
between
(Service Provider Name)
And
THE CITY OF MIDWEST CITY

for the benefit of the **Service Provider** and the **City**, and none of the provisions hereof are intended to benefit any third parties.

19. VENUE AND CHOICE OF LAW

All parties hereto expressly agree that the venue of any litigation relating to or involving this **Agreement** and/or the rights, obligations, duties and covenants therein shall be in the appropriate court (state or federal) located in Oklahoma County, Oklahoma. All parties agree that this **Agreement** shall be interpreted and enforced in accordance with Oklahoma law and all rights of the parties shall be determined in accordance with Oklahoma law.

20. DISPUTE RESOLUTION

Either **Party** may commence the dispute resolution process pursuant to this provision, by providing the other **Party** written notice of the dispute between the **Parties** concerning any term of this **Agreement** or attachment hereto. The notice shall contain:

- (i) a statement setting forth the position of the party giving such notice and a summary of arguments supporting such position and
- (ii) the name and title of **Party** Representative and any other Persons who will accompany the Representative at the meeting at which the parties will attempt to settle the Dispute.

Within ten (10) days of receipt of the notice, the other **Party** shall respond with

- (i) a statement setting forth the position of the party giving such notice and a summary of arguments supporting such position and
- (ii) the name and title of **Party** Representative and any other Persons who will accompany the Representative at the meeting at which the parties will attempt to settle the Dispute.

The **Parties** shall make good faith attempts to negotiate a settlement between their appointed representatives. If the **Parties** are unable to settle the dispute themselves, the **Parties** shall be required to mediate the dispute, with the **Parties** equally sharing in the cost of said mediation.

CONSTRUCTION SERVICES AGREEMENT
between
(Service Provider Name)
And
THE CITY OF MIDWEST CITY

Mediation shall last at least six (6) hours and be attempted before any litigation shall be filed.

21. VALIDITY

The invalidity or unenforceability of any provision of this **Agreement** shall not affect the validity or enforceability of any other provisions of this **Agreement**, which shall remain in full force and effect.

22. NO WAIVER

The failure or neglect of either of the **Parties** hereto to insist, in any one or more instances, upon the strict performance of any of the terms or conditions of this **Agreement**, or waiver by any party of strict performance of any of the terms or conditions of this **Agreement**, shall not be construed as a waiver or relinquishment in the future of such term or condition, but such term or condition shall continue in full force and effect.

23. NO EXTRA WORK

No claims for extra work, product, services, solution, or deliverables of any kind or nature or character shall be recognized or paid by or be binding upon the **City** unless such services, work, product, solution, or deliverable is first requested and approved in writing by the **City** through a purchase order.

24. AMENDMENT

This **Agreement** may be amended by mutual agreement of the **Parties**, in writing and signed by both **Parties**. The **City** hereby delegates to the City Manager all amendments to this **Agreement** for approval and execution, unless the amendment would increase the contracted amount by more than ten percent (10%).

CONSTRUCTION SERVICES AGREEMENT
between
(Service Provider Name)
And
THE CITY OF MIDWEST CITY

25. EFFECTIVE DATE

The Effective Date of this **Agreement** is the date approved by the **City** as the last party hereto.

[REMAINDER OF THIS PAGE INTENTIONALLY LEFT BANK]

CONSTRUCTION SERVICES AGREEMENT
between
(Service Provider Name)
And
THE CITY OF MIDWEST CITY

IN WITNESS WHEREOF, the parties have caused their properly authorized representatives to execute this **Agreement** on the dates set forth below.

Service Provider: _____ (Name of Service Provider)

By: _____

Name: _____

Title: _____

[REMAINDER OF THIS PAGE INTENTIONALLY LEFT BANK]

CONSTRUCTION SERVICES AGREEMENT
between
(Service Provider Name)
And
THE CITY OF MIDWEST CITY

APPROVED by the Council and **SIGNED** by the Mayor of The City of Midwest City this
_____ day of _____, 2024.

THE CITY OF MIDWEST CITY

MATT DUKES, MAYOR

SARA HANCOCK, CITY CLERK

REVIEWED for form and legality.

DONALD D. MAISCH, CITY ATTORNEY

STATUTORY BOND

KNOW ALL BY THESE PRESENTS:

That _____, as Principal, and _____, a corporation organized under the laws of the State of _____, and authorized to transact business in the State of Oklahoma, as Surety, are held and firmly bound unto the City of Midwest City in the penal sum of _____ Dollars (\$_____) in lawful money of the United States of America, for the payment of which, well and truly to be made, we bind ourselves and each of us, our heirs, executors, administrators, trustees, successors, and assigns, jointly and severally, firmly by these presents.

DATED this _____ day of _____, 2024.

The condition of this obligation is such that:

WHEREAS, Principal entered into a written contract with the City of Midwest City dated _____, 2024, for:

**MIDWEST CITY
100 N MIDWEST BLVD
REPLACEMENT OF AHU 6&8**

all in compliance with the plans and specifications therefor, made a part of said Contract and on file in the office of the City Clerk, City of Midwest City, 100 N. Midwest Boulevard, Midwest City, Oklahoma 73110.

NOW, THEREFORE, if Principal shall fail or neglect to pay all indebtedness incurred by Principal or subcontractors of Principal who perform work in the performance of said contract for labor and materials and repairs to and parts for equipment used and consumed in the performance of said Contract within thirty (30) days after the same becomes due and payable, the person, firm or corporation entitled thereto may sue and recover on this bond the amount so due and unpaid.

It is further expressly agreed and understood by the parties to said Contract that no changes or alterations in said Contract and no deviations from the plan or mode of procedure herein fixed shall have the effect of releasing the sureties, or any of them, from the obligations of this Bond.

IN WITNESS WHEREOF, Principal has caused these presents to be executed in its name and its corporate seal to be hereunto affixed by its duly authorized officers, and Surety has caused these presents to be executed in its name and its corporate seal to be hereunto affixed by its attorney-in-fact duly authorized so to do, the day and year first above written.

Principal:

By _____
Title

ATTEST:

Surety:

By _____
Attorney-in-Fact

PERFORMANCE BOND

KNOW ALL BY THESE PRESENTS:

That _____,as
Principal, and _____, a
corporation organized under the laws of the State of _____ and
authorized to transact business in the State of Oklahoma, as Surety, are held and firmly bound unto the
City of Midwest City in the penal sum of _____ Dollars
(\$_____) in lawful money of the United States of America, for the payment of which, well and
truly to be made, we bind ourselves and each of us, our heirs, executors, administrators, trustees,
successors, and assigns, jointly and severally, firmly by these presents.

DATED this _____ day of _____, 2024.

The condition of this obligation is such that:

WHEREAS, Principal entered into a written Contract with the City of Midwest City dated __
_____, 2024, for:

**MIDWEST CITY
100 N MIDWEST BLVD
REPLACEMENT OF AHU 6&8**

all in compliance with the plans and specifications therefor, made a part of said Contract and on file in
the office of the City Clerk, City of Midwest City, 100 N. Midwest Boulevard, Midwest City, Oklahoma
73110.

NOW, THEREFORE, if Principal shall, in all particulars, well, truly, and faithfully perform and
abide by said Contract and each and every covenant, condition, and part thereof and shall fulfill all
obligations resting upon Principal by the terms of said Contract and said specifications; and if Principal
shall promptly pay, or cause to be paid, all labor, materials and/or repairs and all bills for labor performed
on said work, whether by subcontract or otherwise; and if Principal shall protect and save harmless the
City of Midwest City from all loss, damage, and expense to life or property suffered or sustained by any
person, firm, or corporation caused by Principal or his or its agents, servants, or employees in the
construction of said work, or by or in consequence of any negligence, carelessness or misconduct in
guarding and protecting the same, or from any act or omission of Principal or his or its agents, servants,
or employees in the construction of said work, or by or in consequence of any negligence, carelessness
or misconduct in guarding and protecting the same, or from any act or omission of Principal shall protect
and save the City of Midwest City harmless from all suits and claims of infringement or alleged
infringement or patent rights or processes, then this obligation shall be null and void, otherwise it shall
be and remain in full force and effect.

It is further expressly agreed and understood by the parties hereto that no changes or alterations in said Contract and no deviations from the plan or mode of procedure herein fixed shall have the effect of releasing the sureties, or any of them, from the obligations of this Bond.

IN WITNESS WHEREOF, Principal has caused these presents to be executed in its name and its corporate seal to be hereunto affixed by its duly authorized officers, and Surety has caused these presents to be executed in its name and its corporate seal to be hereunto affixed by its attorney-in-fact duly authorized so to do, the day and year first above written.

Principal:

By _____
Title

ATTEST:

Surety:

By _____
Attorney-in-Fact

MAINTENANCE BOND

KNOW ALL BY THESE PRESENTS:

That _____, as Principal, and _____, a corporation organized under the laws of the State of _____, and authorized to transact business in the State of Oklahoma, as Surety, are held and firmly bound unto the City of Midwest City in the penal sum of _____ Dollars (\$_____) in lawful money of the United States of America, said sum being equal to one hundred percent (100%) of the contract price, for the payment of which, well and truly to be made, we bind ourselves and each of us, our heirs, executors, administrators, trustees, successors, and assigns, jointly and severally, firmly by these presents.

DATED this _____ day of _____, 2024.

The condition of this obligation is such that:

WHEREAS, Principal entered into a written Contract with the City of Midwest City dated _____, 2024, for:

**MIDWEST CITY
100 N MIDWEST City
REPLACEMENT OF AHU 6&8**

all in compliance with the plans and specifications therefor, made a part of said Contract and on file in the office of the City Clerk, City of Midwest City, 100 N. Midwest Boulevard, Midwest City, Oklahoma 73110.

NOW, THEREFORE, if Principal shall pay or cause to be paid to the City of Midwest City all damage, loss and expense which may result by reason of defective materials and/or workmanship in connection with said work occurring within **ONE (1) years** from and after acceptance of said project by the City of Midwest City; and if Principal shall pay or cause to be paid all labor and materials, including the prime contractor and all subcontractors; and if Principal shall save and hold the City of Midwest City harmless from all damages, loss and expense occasioned by or resulting from any failure whatsoever of Principal, then this obligation shall be null and void, otherwise to be and remain in full force and effect.

It is further expressly agreed and understood by the parties hereto that no changes or alterations in said Contract and no deviations from the plan or mode of procedure herein fixed shall have the effect of releasing the sureties, or any of them, from the obligations of this Bond.

IN WITNESS WHEREOF, Principal has caused these presents to be executed in its name and its corporate seal to be hereunto affixed by its duly authorized officers, and Surety has caused these presents to be executed in its name and its corporate seal to be hereunto affixed by its attorney-in-fact duly authorized so to do, the day and year first above written.

Principal:

By _____
Title

ATTEST:

Surety:

By _____
Attorney-in-Fact

Approved as to form this _____ day of _____, 2024.

City Attorney

BID

Proposal of _____
_____, (hereinafter called BIDDER"),
organized and existing under the laws of the State of _____
doing business as * _____

To the **CITY OF MIDWEST CITY** (hereinafter called "CITY").

In compliance with your Advertisement for Bids, BIDDER hereby proposes to perform all work for the construction of the following:

**MIDWEST CITY
100 N MIDWEST BLVD
REPLACEMENT OF Air Handler Units 6&8**

in strict accordance with the CONTRACT DOCUMENTS, within the time set forth therein, and at the prices stated below.

By submission of this BID, each BIDDER certifies, and in the case of joint BID each party thereto certifies as to his own organization, that this BID has been arrived at independently, without consultation, communication or agreement as to any matter relating to this BID with any other BIDDER or with any competitor.

BIDDER hereby agrees to commence work under the contract documents on or before a date to be specified in the NOTICE TO PROCEED and to fully complete the Project within (_____) consecutive calendar days thereafter. BIDDER further agrees to pay as liquidated damages the daily rate determined by Table 108:1, Schedule of Liquidated Damages in ODOT Specifications section 108.09, and accessed for each consecutive calendar day thereafter as provided in Section 14 of the General Conditions.

BIDDER acknowledges receipt of the following ADDENDUM:

* Insert "a corporation," "a partnership" or "an individual" as applicable.

BIDDER agrees to perform all the work described in the CONTRACT DOCUMENTS for the unit prices or lump sum as indicated on the detailed bid form. The CITY shall have the option to deduct any or all of the bid items at the unit cost or lump sum provided by the BIDDER.

BASE BID TOTAL (from DBF-1) \$ _____

(Total dollars written)

ALTERNATE 1 TOTAL (from DBF-1) \$ _____

(Total dollars written)

Respectfully submitted:

Signature

Address

Title

Date

License Number (if applicable)

(SEAL - If Bid is by a Corporation)

ATTEST: _____

**MIDWEST CITY
100 N MIDWEST BLVD
REPLACEMENT OF AIR HANDLE UNITS 6&8**

DETAILED BID FORM

Detailed bids shown below shall reflect all related project costs including, but not limited to, equipment, materials, labor, overhead and profit for installation and construction of each item per the drawings and specifications. Any item required for a complete and functional installation shall be included/distributed in the most relevant pay item. Contractor is responsible for verifying quantities. See Appendix I to the Instructions to Bidders for directions and a sample Detailed Bid Form.

BASE BID (ITEMS 1-3)

<u>Pay Item</u>	<u>Estimated Quantity</u>	<u>Unit</u>	<u>Item</u>	<u>Unit Price</u>	<u>Item Total</u>
1.	2.00	LSUM	PUMP SYSTEM		
				Dollars	\$ _____
<i>(Dollars per unit written)</i>					
2.	6.00	LB	Fan COIL SYSTEM		
				Dollars	\$ _____
<i>(Dollars per unit written)</i>					
3.	1.00	CY	AHU 8		
				Dollars	\$ _____
<i>(Dollars per unit written)</i>					

BASE BID SUBTOTAL (Sum of Items 1-3)

				Dollars	\$ _____
<i>(Dollars per unit written)</i>					

ADD ALTERNATE 1 (ITEM 4)

<u>Pay Item</u>	<u>Estimated Quantity</u>	<u>Unit</u>	<u>Item</u>	<u>Unit Price</u>	<u>Item Total</u>
4.	1.00	LSUM	AHU-6		
				Dollars	\$ _____
<i>(Dollars per unit written)</i>					

<u>Pay Item</u>	<u>Estimated Quantity</u>	<u>Unit</u>	<u>Item</u>	<u>Unit Price</u>	<u>Item Total</u>
------------------------	----------------------------------	--------------------	--------------------	--------------------------	--------------------------

BASE BID PLUS ADD ALTERNATE 1 TOTAL (SUM OF ITEMS 1-4)

**NONCOLLUSION AFFIDAVIT
THIS AFFIDAVIT MUST ACCOMPANY THE BID**

City of Midwest City, Oklahoma

I, _____
Owner, Partner, Officer of Firm

Company Name, City and State

being first duly sworn upon oath, state: I, the Company, its officers or employees, have not been party to any agreement or collusion among bidders, prospective bidders, architects or any other persons, or any other companies, in restraint of freedom of competition by agreement to bid at a fixed price or to refrain from bidding or otherwise on this project for:

**MIDWEST CITY
100 N MIDWEST BLVD
REPLACEMENT OF AHU 6&8**

for the City of Midwest City.

Firm Name

Signature and Title

Subscribed and sworn to before me this _____ day of _____, 2024.

Notary Public

My Commission Expires:

CERTIFICATION OF PRE-BID SITE INSPECTION

I, _____,

representing

_____, certify that on the ____ day of _____, 2024, I inspected the project site located in Midwest City. I am thoroughly familiar and aware of all conditions at the site and problems that may be encountered during performance of the referenced project:

**MIDWEST CITY
100 N MIDWEST BLVD
REPLACEMENT OF AHU 6&8**

BY: _____
Name

TITLE: _____

All bidders must inspect the project work site prior to submitting a bid. Therefore, a mandatory pre-bid conference is scheduled as specified in the Notice to Bidders.

BID BOND

KNOW ALL PEOPLE BY THESE PRESENTS, that we, the undersigned, _____, as Principal, and _____, as Surety, are hereby held and firmly bound unto the City of Midwest City in the penal sum of _____ for the payment of which, well and truly to be made, we hereby jointly and severally bind ourselves, our successors and assigns.

Signed this _____ day of _____, 2024.

The condition of the above obligation is such that whereas the Principal has submitted to the City of Midwest City a certain Bid, attached hereto and hereby made a part hereof to enter into a contract in writing, for the:

**MIDWEST CITY
100 N MIDWEST BLVD
REPLACEMENT OF AHU 6&8**

NOW, THEREFORE,

(a) If said Bid shall be rejected or, in the alternate,
(b) If said Bid shall be accepted and the Principal shall execute and deliver a contract in the form of contract attached hereto (properly completed in accordance with said Bid) and shall furnish a bond for his faithful performance of said contract, and for the payment of all persons performing labor or furnishing materials in connection therewith, and shall in all other respects perform the agreement created by the acceptance of said Bid, then this obligation shall be void, otherwise the same shall remain in force and effect. It is expressly understood and agreed that the liability of the Surety for any and all claims hereunder shall, in no event, exceed the penal amount of this obligation as herein stated.

The Surety, for value received, hereby stipulates and agrees that the obligations of said Surety and its bond shall be in no way impaired or affected by any extension of the time within which the City may accept such bid; and said Surety does hereby waive notice of any extension.

IN WITNESS WHEREOF, the Principal and the Surety have hereunder set their hands and seals, and such of them as are corporations have caused their corporate seals to be hereto affixed and these presents to be signed by their proper officers, the day and year first set forth above.

Principal

Surety

By: _____

Contractor Certification

Contractor certifies and warrants that it will comply with the Immigration Laws of the United States, including but not limited to 8 USC 1324(a), which makes it unlawful for an employer to hire or continue to employ an illegal or undocumented alien *knowing* the alien is or has become unauthorized with respect to such employment, or to fail to comply with the I-9 requirements. Contractor further agrees to comply with the Oklahoma Taxpayer and Citizen Protection Act of 2007. Contractor will not knowingly employ or knowingly allow any of its Subcontractors to employ any illegal or undocumented aliens to perform any work in connection with services performed for the City of Midwest City. After July 1, 2008, Contractor and its Subcontractors will verify information on all new employees on the Status Verification System operated by the U.S. Government.

Contractor will retain and make available for inspection by the City, upon reasonable notice, a completed I-9 Employment Eligibility Verification Form for each person that contractor directly employs to perform services for the City. If Contractor, or any of its Subcontractors, receives *actual knowledge* of the unauthorized status of one of its employees engaged in providing services to the City, then Contractor or Subcontractor will remove that employee from the project, and shall require each Sub-contractor to act in a similar fashion with respect to such Sub-contractor's employees. Contractor agrees to have a provision in its subcontracts stating that each Sub-contractor will have the same duties and responsibilities with regard to its employees that the Contractor has certified in this paragraph.

Signed under penalty of perjury on _____, 2024.

Contractor

By: _____
Owner or Authorized Officer

STATEMENT OF BIDDER'S QUALIFICATIONS
(Site Preparation Contractor)

All questions must be answered. All responses must be clear and comprehensive. This statement must be notarized. If necessary, questions may be answered on separate sheets. The Bidder may submit any additional information.

1. Name of Bidder:

2. Permanent main office address:

3. When organized:

4. If a corporation, where incorporated:

5. How many years have you been engaged in the contracting business under your present firm or trade name:

6. Contracts on hand (Schedule these, showing amount of each contract and the appropriate anticipated dates of completion):

7. General character of work performed by your company:

8. Have you ever failed to complete any work awarded to you?

9. Have you ever defaulted on a contract?

10. List the more important projects recently completed by your company, stating the approximate cost for each and the month and year completed.

11. List your major equipment available for this contract

12. Experience in construction work similar in scope to this project:

13. Background and experience of the principal members of your organization, including officers:

14. Credit available:
 \$ _____
15. Give bank reference:

16. Will you, upon request by the City of Midwest City, provide a detailed financial statement and furnish other information that may be requested within ten (10) working days from the date of the request?

17. The undersigned hereby authorizes and requests any person, firm or corporation to furnish any information requested by the City of Midwest City in verification of the recitals comprising this Statement of Bidder's Qualifications.

DATED this _____ day of _____, 2024.

 (Name of Bidder)

By: _____

Title: _____

STATE OF _____)
)ss
 COUNTY OF _____)

_____, being duly sworn, states that
 he/she is the _____
 (Name of Organization)
 of _____

 (Title)

and that the answers to the foregoing questions and all statements therein contained are true and correct.

Subscribed and sworn to before me this _____ day of _____, 2024.

 Notary Public

My commission expires: _____

INSTRUCTIONS TO BIDDERS
APPENDIX 1
INSTRUCTIONS FOR COMPLETION OF THE DETAILED BID FORM

Detailed Bid Forms are included in the Bidding Documents when projects are bid all or partially on a unit cost basis. Where a Detailed Bid Form is provided, Bidder is to enter the cost per unit in words and in numerals and then enter the total cost of the item (unit cost x estimated quantity) in the right hand column under "Item Total".

The Total of the Item Total Column should be entered at the bottom of the Detailed Bid Form and on the "Amount Bid" line on the Bid Form. Bidders should check to insure that the total of the Detailed Bid Form is entered correctly on the Bid Form. In cases of conflict between words and numerals, the words will govern. In cases of conflict between the amount on the Bid Form and the amount on the Detailed Bid Form, the amount on the Detailed Bid Form will govern.

There may be a Detailed Bid Form for one or more of any Alternates. If a Detailed Bid Form is provided for an Alternate, it should be completed in the same manner as the Form for the Base Bid.

An example of a correctly completed Detailed Bid Form is provided below.

DETAILED BID FORM ITEMS

PROJECT NO. _____

<u>Pay Item</u>	<u>Estimated Quantity</u>	<u>Unit</u>	<u>Item</u>	<u>Unit Price</u>	<u>Item Total</u>
1.	45	S.Y.	6" P.C. Concrete		
<hr/>				Dollars	\$ <u>15.00</u> \$ <u>675.00</u>
<i>Fifteen and no/100</i>					
<i>(Dollars per unit written)</i>					
2.	70	L.F.	6" Integral Curb		
<hr/>				Dollars	\$ <u>1.50</u> \$ <u>105.00</u>
<i>One and 50/100</i>					
<i>(Dollars per unit written)</i>					
3.	56	L.F.	6" Curb Removal		
<hr/>				Dollars	\$ <u>2.13</u> \$ <u>119.28</u>
<i>Two and 13/100</i>					
<i>Three and no/100 MC</i>					<i>3.00 MC 168.00 MC</i>
<i>(Dollars per unit written)</i>					
4.	1	L.S.	Plug Existing 42" R.C.P. (3 pts.)		
<hr/>				Dollars	\$ <u>300.00</u> \$ <u>300.00</u>
<i>Three Hundred and no/100</i>					
<i>(Dollars per unit written)</i>					
5.	45	L.F.	24" R.C.P.		
<hr/>				Dollars	\$ <u>30.00</u> \$ <u>1,350.00</u>
<i>Thirty and no/100</i>					
<i>(Dollars per unit written)</i>					

APX-1

TOTAL \$ 2,598.00 MC
~~2,549.28~~

This content is from the eCFR and is authoritative but unofficial.

Title 29 – Labor

Subtitle A – Office of the Secretary of Labor

Part 5 – Labor Standards Provisions Applicable to Contracts Covering Federally Financed and Assisted Construction (Also Labor Standards Provisions Applicable to Nonconstruction Contracts Subject to the Contract Work Hours and Safety Standards Act)

Subpart A – Davis-Bacon and Related Acts Provisions and Procedures

Source: 48 FR 19540, Apr. 29, 1983, unless otherwise noted.

Authority: 5 U.S.C. 301; Reorganization Plan No. 14 of 1950, 5 U.S.C. appendix; 28 U.S.C. 2461 note; 40 U.S.C. 3141 *et seq.*; 40 U.S.C. 3145; 40 U.S.C. 3148; 40 U.S.C. 3701 *et seq.*; Secretary's Order No. 01–2014, 79 FR 77527; and the laws referenced by § 5.1(a).

Source: 48 FR 19541, Apr. 29, 1983, unless otherwise noted.

Editorial Note: Nomenclature changes to subpart A of part 5 appear at 61 FR 19984, May 3, 1996.

§ 5.5 Contract provisions and related matters.

Link to an amendment published at 88 FR 57734, Aug. 23, 2023.

(a) **Required contract clauses.** The Agency head will cause or require the contracting officer to require the contracting officer to insert in full, or (for contracts covered by the Federal Acquisition Regulation (48 CFR chapter 1)) by reference, in any contract in excess of \$2,000 which is entered into for the actual construction, alteration and/or repair, including painting and decorating, of a public building or public work, or building or work financed in whole or in part from Federal funds or in accordance with guarantees of a Federal agency or financed from funds obtained by pledge of any contract of a Federal agency to make a loan, grant or annual contribution (except where a different meaning is expressly indicated), and which is subject to the labor standards provisions of any of the laws referenced by § 5.1, the following clauses (or any modifications thereof to meet the particular needs of the agency, *Provided*, That such modifications are first approved by the Department of Labor):

(1) **Minimum wages –**

(i) **Wage rates and fringe benefits.** All laborers and mechanics employed or working upon the site of the work (or otherwise working in construction or development of the project under a development statute), will be paid unconditionally and not less often than once a week, and without subsequent deduction or rebate on any account (except such payroll deductions as are permitted by regulations issued by the Secretary of Labor under the Copeland Act (29 CFR part 3)), the full amount of basic hourly wages and bona fide fringe benefits (or cash equivalents thereof) due at time of payment computed at rates not less than those contained in the wage determination of the Secretary of Labor which is attached hereto and made a part hereof, regardless of any contractual relationship which may be alleged to exist between the contractor and such laborers and mechanics. As provided in paragraphs (d) and (e) of this section, the appropriate wage determinations are effective by operation of law even if they have not been attached to the contract. Contributions made or costs reasonably anticipated for bona fide fringe benefits under the Davis-Bacon Act (40 U.S.C. 3141(2)(B)) on behalf of laborers or mechanics are considered wages paid to such laborers or mechanics, subject to the provisions

of paragraph (a)(1)(v) of this section; also, regular contributions made or costs incurred for more than a weekly period (but not less often than quarterly) under plans, funds, or programs which cover the particular weekly period, are deemed to be constructively made or incurred during such weekly period. Such laborers and mechanics must be paid the appropriate wage rate and fringe benefits on the wage determination for the classification(s) of work actually performed, without regard to skill, except as provided in paragraph (a)(4) of this section. Laborers or mechanics performing work in more than one classification may be compensated at the rate specified for each classification for the time actually worked therein: *Provided*, That the employer's payroll records accurately set forth the time spent in each classification in which work is performed. The wage determination (including any additional classifications and wage rates conformed under paragraph (a)(1)(iii) of this section) and the Davis-Bacon poster (WH-1321) must be posted at all times by the contractor and its subcontractors at the site of the work in a prominent and accessible place where it can be easily seen by the workers.

(ii) **Frequently recurring classifications.**

(A) In addition to wage and fringe benefit rates that have been determined to be prevailing under the procedures set forth in 29 CFR part 1, a wage determination may contain, pursuant to § 1.3(f), wage and fringe benefit rates for classifications of laborers and mechanics for which conformance requests are regularly submitted pursuant to paragraph (a)(1)(iii) of this section, provided that:

- (1) The work performed by the classification is not performed by a classification in the wage determination for which a prevailing wage rate has been determined;
- (2) The classification is used in the area by the construction industry; and
- (3) The wage rate for the classification bears a reasonable relationship to the prevailing wage rates contained in the wage determination.

(B) The Administrator will establish wage rates for such classifications in accordance with paragraph (a)(1)(iii)(A)(3) of this section. Work performed in such a classification must be paid at no less than the wage and fringe benefit rate listed on the wage determination for such classification.

(iii) **Conformance.**

(A) The contracting officer must require that any class of laborers or mechanics, including helpers, which is not listed in the wage determination and which is to be employed under the contract be classified in conformance with the wage determination. Conformance of an additional classification and wage rate and fringe benefits is appropriate only when the following criteria have been met:

- (1) The work to be performed by the classification requested is not performed by a classification in the wage determination; and
- (2) The classification is used in the area by the construction industry; and
- (3) The proposed wage rate, including any bona fide fringe benefits, bears a reasonable relationship to the wage rates contained in the wage determination.

(B) The conformance process may not be used to split, subdivide, or otherwise avoid application of classifications listed in the wage determination.

- (C) If the contractor and the laborers and mechanics to be employed in the classification (if known), or their representatives, and the contracting officer agree on the classification and wage rate (including the amount designated for fringe benefits where appropriate), a report of the action taken will be sent by the contracting officer by email to DBAconformance@dol.gov. The Administrator, or an authorized representative, will approve, modify, or disapprove every additional classification action within 30 days of receipt and so advise the contracting officer or will notify the contracting officer within the 30-day period that additional time is necessary.
 - (D) In the event the contractor, the laborers or mechanics to be employed in the classification or their representatives, and the contracting officer do not agree on the proposed classification and wage rate (including the amount designated for fringe benefits, where appropriate), the contracting officer will, by email to DBAconformance@dol.gov, refer the questions, including the views of all interested parties and the recommendation of the contracting officer, to the Administrator for determination. The Administrator, or an authorized representative, will issue a determination within 30 days of receipt and so advise the contracting officer or will notify the contracting officer within the 30-day period that additional time is necessary.
 - (E) The contracting officer must promptly notify the contractor of the action taken by the Wage and Hour Division under paragraphs (a)(1)(iii)(C) and (D) of this section. The contractor must furnish a written copy of such determination to each affected worker or it must be posted as a part of the wage determination. The wage rate (including fringe benefits where appropriate) determined pursuant to paragraph (a)(1)(iii)(C) or (D) of this section must be paid to all workers performing work in the classification under this contract from the first day on which work is performed in the classification.
 - (iv) **Fringe benefits not expressed as an hourly rate.** Whenever the minimum wage rate prescribed in the contract for a class of laborers or mechanics includes a fringe benefit which is not expressed as an hourly rate, the contractor may either pay the benefit as stated in the wage determination or may pay another bona fide fringe benefit or an hourly cash equivalent thereof.
 - (v) **Unfunded plans.** If the contractor does not make payments to a trustee or other third person, the contractor may consider as part of the wages of any laborer or mechanic the amount of any costs reasonably anticipated in providing bona fide fringe benefits under a plan or program, *Provided*, That the Secretary of Labor has found, upon the written request of the contractor, in accordance with the criteria set forth in § 5.28, that the applicable standards of the Davis-Bacon Act have been met. The Secretary of Labor may require the contractor to set aside in a separate account assets for the meeting of obligations under the plan or program.
 - (vi) **Interest.** In the event of a failure to pay all or part of the wages required by the contract, the contractor will be required to pay interest on any underpayment of wages.
- (2) **Withholding** –
- (i) **Withholding requirements.** The [write in name of Federal agency or the recipient of Federal assistance] may, upon its own action, or must, upon written request of an authorized representative of the Department of Labor, withhold or cause to be withheld from the contractor so much of the accrued payments or advances as may be considered necessary to satisfy the liabilities of the prime contractor or any subcontractor for the full amount of wages and monetary relief, including interest, required by the clauses set forth in paragraph (a) of this

section for violations of this contract, or to satisfy any such liabilities required by any other Federal contract, or federally assisted contract subject to Davis-Bacon labor standards, that is held by the same prime contractor (as defined in § 5.2). The necessary funds may be withheld from the contractor under this contract, any other Federal contract with the same prime contractor, or any other federally assisted contract that is subject to Davis-Bacon labor standards requirements and is held by the same prime contractor, regardless of whether the other contract was awarded or assisted by the same agency, and such funds may be used to satisfy the contractor liability for which the funds were withheld. In the event of a contractor's failure to pay any laborer or mechanic, including any apprentice or helper working on the site of the work (or otherwise working in construction or development of the project under a development statute) all or part of the wages required by the contract, or upon the contractor's failure to submit the required records as discussed in paragraph (a)(3)(iv) of this section, the [Agency] may on its own initiative and after written notice to the contractor, sponsor, applicant, owner, or other entity, as the case may be, take such action as may be necessary to cause the suspension of any further payment, advance, or guarantee of funds until such violations have ceased.

(ii) **Priority to withheld funds.** The Department has priority to funds withheld or to be withheld in accordance with paragraph (a)(2)(i) or (b)(3)(i) of this section, or both, over claims to those funds by:

- (A) A contractor's surety(ies), including without limitation performance bond sureties and payment bond sureties;
- (B) A contracting agency for its procurement costs;
- (C) A trustee(s) (either a court-appointed trustee or a U.S. trustee, or both) in bankruptcy of a contractor, or a contractor's bankruptcy estate;
- (D) A contractor's assignee(s);
- (E) A contractor's successor(s); or
- (F) A claim asserted under the Prompt Payment Act, 31 U.S.C. 3901–3907.

(3) **Records and certified payrolls –**

(i) **Basic record requirements –**

- (A) **Length of record retention.** All regular payrolls and other basic records must be maintained by the contractor and any subcontractor during the course of the work and preserved for all laborers and mechanics working at the site of the work (or otherwise working in construction or development of the project under a development statute) for a period of at least 3 years after all the work on the prime contract is completed.
- (B) **Information required.** Such records must contain the name; Social Security number; last known address, telephone number, and email address of each such worker; each worker's correct classification(s) of work actually performed; hourly rates of wages paid (including rates of contributions or costs anticipated for bona fide fringe benefits or cash equivalents thereof of the types described in 40 U.S.C. 3141(2)(B) of the Davis-Bacon Act); daily and weekly number of hours actually worked in total and on each covered contract; deductions made; and actual wages paid.

- (C) **Additional records relating to fringe benefits.** Whenever the Secretary of Labor has found under paragraph (a)(1)(v) of this section that the wages of any laborer or mechanic include the amount of any costs reasonably anticipated in providing benefits under a plan or program described in 40 U.S.C. 3141(2)(B) of the Davis-Bacon Act, the contractor must maintain records which show that the commitment to provide such benefits is enforceable, that the plan or program is financially responsible, and that the plan or program has been communicated in writing to the laborers or mechanics affected, and records which show the costs anticipated or the actual cost incurred in providing such benefits.
 - (D) **Additional records relating to apprenticeship.** Contractors with apprentices working under approved programs must maintain written evidence of the registration of apprenticeship programs, the registration of the apprentices, and the ratios and wage rates prescribed in the applicable programs.
- (ii) **Certified payroll requirements –**
- (A) **Frequency and method of submission.** The contractor or subcontractor must submit weekly, for each week in which any DBA- or Related Acts-covered work is performed, certified payrolls to the [write in name of appropriate Federal agency] if the agency is a party to the contract, but if the agency is not such a party, the contractor will submit the certified payrolls to the applicant, sponsor, owner, or other entity, as the case may be, that maintains such records, for transmission to the [write in name of agency]. The prime contractor is responsible for the submission of all certified payrolls by all subcontractors. A contracting agency or prime contractor may permit or require contractors to submit certified payrolls through an electronic system, as long as the electronic system requires a legally valid electronic signature; the system allows the contractor, the contracting agency, and the Department of Labor to access the certified payrolls upon request for at least 3 years after the work on the prime contract has been completed; and the contracting agency or prime contractor permits other methods of submission in situations where the contractor is unable or limited in its ability to use or access the electronic system.
 - (B) **Information required.** The certified payrolls submitted must set out accurately and completely all of the information required to be maintained under paragraph (a)(3)(i)(B) of this section, except that full Social Security numbers and last known addresses, telephone numbers, and email addresses must not be included on weekly transmittals. Instead, the certified payrolls need only include an individually identifying number for each worker (e.g., the last four digits of the worker's Social Security number). The required weekly certified payroll information may be submitted using Optional Form WH-347 or in any other format desired. Optional Form WH-347 is available for this purpose from the Wage and Hour Division website at <https://www.dol.gov/sites/dolgov/files/WHD/legacy/files/wh347.pdf> or its successor website. It is not a violation of this section for a prime contractor to require a subcontractor to provide full Social Security numbers and last known addresses, telephone numbers, and email addresses to the prime contractor for its own records, without weekly submission by the subcontractor to the sponsoring government agency (or the applicant, sponsor, owner, or other entity, as the case may be, that maintains such records).

- (C) **Statement of Compliance.** Each certified payroll submitted must be accompanied by a “Statement of Compliance,” signed by the contractor or subcontractor, or the contractor's or subcontractor's agent who pays or supervises the payment of the persons working on the contract, and must certify the following:
 - (1) That the certified payroll for the payroll period contains the information required to be provided under paragraph (a)(3)(ii) of this section, the appropriate information and basic records are being maintained under paragraph (a)(3)(i) of this section, and such information and records are correct and complete;
 - (2) That each laborer or mechanic (including each helper and apprentice) working on the contract during the payroll period has been paid the full weekly wages earned, without rebate, either directly or indirectly, and that no deductions have been made either directly or indirectly from the full wages earned, other than permissible deductions as set forth in 29 CFR part 3; and
 - (3) That each laborer or mechanic has been paid not less than the applicable wage rates and fringe benefits or cash equivalents for the classification(s) of work actually performed, as specified in the applicable wage determination incorporated into the contract.
- (D) **Use of Optional Form WH–347.** The weekly submission of a properly executed certification set forth on the reverse side of Optional Form WH–347 will satisfy the requirement for submission of the “Statement of Compliance” required by paragraph (a)(3)(ii)(C) of this section.
- (E) **Signature.** The signature by the contractor, subcontractor, or the contractor's or subcontractor's agent must be an original handwritten signature or a legally valid electronic signature.
- (F) **Falsification.** The falsification of any of the above certifications may subject the contractor or subcontractor to civil or criminal prosecution under 18 U.S.C. 1001 and 31 U.S.C. 3729.
- (G) **Length of certified payroll retention.** The contractor or subcontractor must preserve all certified payrolls during the course of the work and for a period of 3 years after all the work on the prime contract is completed.
- (iii) **Contracts, subcontracts, and related documents.** The contractor or subcontractor must maintain this contract or subcontract and related documents including, without limitation, bids, proposals, amendments, modifications, and extensions. The contractor or subcontractor must preserve these contracts, subcontracts, and related documents during the course of the work and for a period of 3 years after all the work on the prime contract is completed.
- (iv) **Required disclosures and access –**
 - (A) **Required record disclosures and access to workers.** The contractor or subcontractor must make the records required under paragraphs (a)(3)(i) through (iii) of this section, and any other documents that the [write the name of the agency] or the Department of Labor deems necessary to determine compliance with the labor standards provisions of any of the applicable statutes referenced by § 5.1, available for inspection, copying, or

transcription by authorized representatives of the [write the name of the agency] or the Department of Labor, and must permit such representatives to interview workers during working hours on the job.

(B) **Sanctions for non-compliance with records and worker access requirements.** If the contractor or subcontractor fails to submit the required records or to make them available, or refuses to permit worker interviews during working hours on the job, the Federal agency may, after written notice to the contractor, sponsor, applicant, owner, or other entity, as the case may be, that maintains such records or that employs such workers, take such action as may be necessary to cause the suspension of any further payment, advance, or guarantee of funds. Furthermore, failure to submit the required records upon request or to make such records available, or to permit worker interviews during working hours on the job, may be grounds for debarment action pursuant to § 5.12. In addition, any contractor or other person that fails to submit the required records or make those records available to WHD within the time WHD requests that the records be produced will be precluded from introducing as evidence in an administrative proceeding under 29 CFR part 6 any of the required records that were not provided or made available to WHD. WHD will take into consideration a reasonable request from the contractor or person for an extension of the time for submission of records. WHD will determine the reasonableness of the request and may consider, among other things, the location of the records and the volume of production.

(C) **Required information disclosures.** Contractors and subcontractors must maintain the full Social Security number and last known address, telephone number, and email address of each covered worker, and must provide them upon request to the [write in name of appropriate Federal agency] if the agency is a party to the contract, or to the Wage and Hour Division of the Department of Labor. If the Federal agency is not such a party to the contract, the contractor, subcontractor, or both, must, upon request, provide the full Social Security number and last known address, telephone number, and email address of each covered worker to the applicant, sponsor, owner, or other entity, as the case may be, that maintains such records, for transmission to the [write in name of agency], the contractor, or the Wage and Hour Division of the Department of Labor for purposes of an investigation or other compliance action.

(4) **Apprentices and equal employment opportunity –**

(i) **Apprentices –**

(A) **Rate of pay.** Apprentices will be permitted to work at less than the predetermined rate for the work they perform when they are employed pursuant to and individually registered in a bona fide apprenticeship program registered with the U.S. Department of Labor, Employment and Training Administration, Office of Apprenticeship (OA), or with a State Apprenticeship Agency recognized by the OA. A person who is not individually registered in the program, but who has been certified by the OA or a State Apprenticeship Agency (where appropriate) to be eligible for probationary employment as an apprentice, will be permitted to work at less than the predetermined rate for the work they perform in the first 90 days of probationary employment as an apprentice in such a program. In the event the OA or a State Apprenticeship Agency recognized by the OA withdraws approval of an

apprenticeship program, the contractor will no longer be permitted to use apprentices at less than the applicable predetermined rate for the work performed until an acceptable program is approved.

- (B) **Fringe benefits.** Apprentices must be paid fringe benefits in accordance with the provisions of the apprenticeship program. If the apprenticeship program does not specify fringe benefits, apprentices must be paid the full amount of fringe benefits listed on the wage determination for the applicable classification. If the Administrator determines that a different practice prevails for the applicable apprentice classification, fringe benefits must be paid in accordance with that determination.
 - (C) **Apprenticeship ratio.** The allowable ratio of apprentices to journeyworkers on the job site in any craft classification must not be greater than the ratio permitted to the contractor as to the entire work force under the registered program or the ratio applicable to the locality of the project pursuant to paragraph (a)(4)(i)(D) of this section. Any worker listed on a payroll at an apprentice wage rate, who is not registered or otherwise employed as stated in paragraph (a)(4)(i)(A) of this section, must be paid not less than the applicable wage rate on the wage determination for the classification of work actually performed. In addition, any apprentice performing work on the job site in excess of the ratio permitted under this section must be paid not less than the applicable wage rate on the wage determination for the work actually performed.
 - (D) **Reciprocity of ratios and wage rates.** Where a contractor is performing construction on a project in a locality other than the locality in which its program is registered, the ratios and wage rates (expressed in percentages of the journeyworker's hourly rate) applicable within the locality in which the construction is being performed must be observed. If there is no applicable ratio or wage rate for the locality of the project, the ratio and wage rate specified in the contractor's registered program must be observed.
- (ii) **Equal employment opportunity.** The use of apprentices and journeyworkers under this part must be in conformity with the equal employment opportunity requirements of Executive Order 11246, as amended, and 29 CFR part 30.
- (5) **Compliance with Copeland Act requirements.** The contractor shall comply with the requirements of 29 CFR part 3, which are incorporated by reference in this contract.
 - (6) **Subcontracts.** The contractor or subcontractor must insert in any subcontracts the clauses contained in paragraphs (a)(1) through (11) of this section, along with the applicable wage determination(s) and such other clauses or contract modifications as the [write in the name of the Federal agency] may by appropriate instructions require, and a clause requiring the subcontractors to include these clauses and wage determination(s) in any lower tier subcontracts. The prime contractor is responsible for the compliance by any subcontractor or lower tier subcontractor with all the contract clauses in this section. In the event of any violations of these clauses, the prime contractor and any subcontractor(s) responsible will be liable for any unpaid wages and monetary relief, including interest from the date of the underpayment or loss, due to any workers of lower-tier subcontractors, and may be subject to debarment, as appropriate.
 - (7) **Contract termination: debarment.** A breach of the contract clauses in 29 CFR 5.5 may be grounds for termination of the contract, and for debarment as a contractor and a subcontractor as provided in 29 CFR 5.12.

- (8) **Compliance with Davis-Bacon and Related Act requirements.** All rulings and interpretations of the Davis-Bacon and Related Acts contained in 29 CFR parts 1, 3, and 5 are herein incorporated by reference in this contract.
- (9) **Disputes concerning labor standards.** Disputes arising out of the labor standards provisions of this contract shall not be subject to the general disputes clause of this contract. Such disputes shall be resolved in accordance with the procedures of the Department of Labor set forth in 29 CFR parts 5, 6, and 7. Disputes within the meaning of this clause include disputes between the contractor (or any of its subcontractors) and the contracting agency, the U.S. Department of Labor, or the employees or their representatives.
- (10) **Certification of eligibility.**
- (i) By entering into this contract, the contractor certifies that neither it nor any person or firm who has an interest in the contractor's firm is a person or firm ineligible to be awarded Government contracts by virtue of 40 U.S.C. 3144(b) or § 5.12(a).
 - (ii) No part of this contract shall be subcontracted to any person or firm ineligible for award of a Government contract by virtue of 40 U.S.C. 3144(b) or § 5.12(a).
 - (iii) The penalty for making false statements is prescribed in the U.S. Code, Title 18 Crimes and Criminal Procedure, 18 U.S.C. 1001.
- (11) **Anti-retaliation.** It is unlawful for any person to discharge, demote, intimidate, threaten, restrain, coerce, blacklist, harass, or in any other manner discriminate against, or to cause any person to discharge, demote, intimidate, threaten, restrain, coerce, blacklist, harass, or in any other manner discriminate against, any worker or job applicant for:
- (i) Notifying any contractor of any conduct which the worker reasonably believes constitutes a violation of the DBA, Related Acts, this part, or 29 CFR part 1 or 3;
 - (ii) Filing any complaint, initiating or causing to be initiated any proceeding, or otherwise asserting or seeking to assert on behalf of themselves or others any right or protection under the DBA, Related Acts, this part, or 29 CFR part 1 or 3;
 - (iii) Cooperating in any investigation or other compliance action, or testifying in any proceeding under the DBA, Related Acts, this part, or 29 CFR part 1 or 3; or
 - (iv) Informing any other person about their rights under the DBA, Related Acts, this part, or 29 CFR part 1 or 3.
- (b) **Contract Work Hours and Safety Standards Act (CWHSSA).** The Agency Head must cause or require the contracting officer to insert the following clauses set forth in paragraphs (b)(1) through (5) of this section in full, or (for contracts covered by the Federal Acquisition Regulation) by reference, in any contract in an amount in excess of \$100,000 and subject to the overtime provisions of the Contract Work Hours and Safety Standards Act. These clauses must be inserted in addition to the clauses required by paragraph (a) of this section or 29 CFR 4.6. As used in this paragraph (b), the terms "laborers and mechanics" include watchpersons and guards.
- (1) **Overtime requirements.** No contractor or subcontractor contracting for any part of the contract work which may require or involve the employment of laborers or mechanics shall require or permit any such laborer or mechanic in any workweek in which he or she is employed on such work to work in

excess of forty hours in such workweek unless such laborer or mechanic receives compensation at a rate not less than one and one-half times the basic rate of pay for all hours worked in excess of forty hours in such workweek.

(2) **Violation; liability for unpaid wages; liquidated damages.** In the event of any violation of the clause set forth in paragraph (b)(1) of this section the contractor and any subcontractor responsible therefor shall be liable for the unpaid wages and interest from the date of the underpayment. In addition, such contractor and subcontractor shall be liable to the United States (in the case of work done under contract for the District of Columbia or a territory, to such District or to such territory), for liquidated damages. Such liquidated damages shall be computed with respect to each individual laborer or mechanic, including watchpersons and guards, employed in violation of the clause set forth in paragraph (b)(1) of this section, in the sum of \$32 for each calendar day on which such individual was required or permitted to work in excess of the standard workweek of forty hours without payment of the overtime wages required by the clause set forth in paragraph (b)(1).

(3) **Withholding for unpaid wages and liquidated damages –**

(i) **Withholding process.** The [write in the name of the Federal agency or the recipient of Federal assistance] may, upon its own action, or must, upon written request of an authorized representative of the Department of Labor, withhold or cause to be withheld from the contractor so much of the accrued payments or advances as may be considered necessary to satisfy the liabilities of the prime contractor or any subcontractor for any unpaid wages; monetary relief, including interest; and liquidated damages required by the clauses set forth in this paragraph (b) on this contract, any other Federal contract with the same prime contractor, or any other federally assisted contract subject to the Contract Work Hours and Safety Standards Act that is held by the same prime contractor (as defined in § 5.2). The necessary funds may be withheld from the contractor under this contract, any other Federal contract with the same prime contractor, or any other federally assisted contract that is subject to the Contract Work Hours and Safety Standards Act and is held by the same prime contractor, regardless of whether the other contract was awarded or assisted by the same agency, and such funds may be used to satisfy the contractor liability for which the funds were withheld.

(ii) **Priority to withheld funds.** The Department has priority to funds withheld or to be withheld in accordance with paragraph (a)(2)(i) or (b)(3)(i) of this section, or both, over claims to those funds by:

- (A) A contractor's surety(ies), including without limitation performance bond sureties and payment bond sureties;
- (B) A contracting agency for its reprocurement costs;
- (C) A trustee(s) (either a court-appointed trustee or a U.S. trustee, or both) in bankruptcy of a contractor, or a contractor's bankruptcy estate;
- (D) A contractor's assignee(s);
- (E) A contractor's successor(s); or
- (F) A claim asserted under the Prompt Payment Act, 31 U.S.C. 3901–3907.

(4) **Subcontracts.** The contractor or subcontractor must insert in any subcontracts the clauses set forth in paragraphs (b)(1) through (5) of this section and a clause requiring the subcontractors to include these clauses in any lower tier subcontracts. The prime contractor is responsible for compliance by

any subcontractor or lower tier subcontractor with the clauses set forth in paragraphs (b)(1) through (5). In the event of any violations of these clauses, the prime contractor and any subcontractor(s) responsible will be liable for any unpaid wages and monetary relief, including interest from the date of the underpayment or loss, due to any workers of lower-tier subcontractors, and associated liquidated damages and may be subject to debarment, as appropriate.

- (5) **Anti-retaliation.** It is unlawful for any person to discharge, demote, intimidate, threaten, restrain, coerce, blacklist, harass, or in any other manner discriminate against, or to cause any person to discharge, demote, intimidate, threaten, restrain, coerce, blacklist, harass, or in any other manner discriminate against, any worker or job applicant for:
- (i) Notifying any contractor of any conduct which the worker reasonably believes constitutes a violation of the Contract Work Hours and Safety Standards Act (CWHSSA) or its implementing regulations in this part;
 - (ii) Filing any complaint, initiating or causing to be initiated any proceeding, or otherwise asserting or seeking to assert on behalf of themselves or others any right or protection under CWHSSA or this part;
 - (iii) Cooperating in any investigation or other compliance action, or testifying in any proceeding under CWHSSA or this part; or
 - (iv) Informing any other person about their rights under CWHSSA or this part.

(c) **CWHSSA required records clause.** In addition to the clauses contained in paragraph (b) of this section, in any contract subject only to the Contract Work Hours and Safety Standards Act and not to any of the other laws referenced by § 5.1, the Agency Head must cause or require the contracting officer to insert a clause requiring that the contractor or subcontractor must maintain regular payrolls and other basic records during the course of the work and must preserve them for a period of 3 years after all the work on the prime contract is completed for all laborers and mechanics, including guards and watchpersons, working on the contract. Such records must contain the name; last known address, telephone number, and email address; and social security number of each such worker; each worker's correct classification(s) of work actually performed; hourly rates of wages paid; daily and weekly number of hours actually worked; deductions made; and actual wages paid. Further, the Agency Head must cause or require the contracting officer to insert in any such contract a clause providing that the records to be maintained under this paragraph must be made available by the contractor or subcontractor for inspection, copying, or transcription by authorized representatives of the (write the name of agency) and the Department of Labor, and the contractor or subcontractor will permit such representatives to interview workers during working hours on the job.

(d) **Incorporation of contract clauses and wage determinations by reference.** Although agencies are required to insert the contract clauses set forth in this section, along with appropriate wage determinations, in full into covered contracts, and contractors and subcontractors are required to insert them in any lower-tier subcontracts, the incorporation by reference of the required contract clauses and appropriate wage determinations will be given the same force and effect as if they were inserted in full text.

(e) **Incorporation by operation of law.** The contract clauses set forth in this section (or their equivalent under the Federal Acquisition Regulation), along with the correct wage determinations, will be considered to be a part of every prime contract required by the applicable statutes referenced by § 5.1 to include such clauses, and will be effective by operation of law, whether or not they are included or incorporated by reference into such contract, unless the Administrator grants a variance, tolerance, or exemption from the

application of this paragraph. Where the clauses and applicable wage determinations are effective by operation of law under this paragraph, the prime contractor must be compensated for any resulting increase in wages in accordance with applicable law.

(The information collection, recordkeeping, and reporting requirements contained in the following paragraphs of this section were approved by the Office of Management and Budget:

Paragraph	OMB Control No.
(a)(1)(ii)(B)	1235-0023
(a)(1)(ii)(C)	1235-0023
(a)(1)(iv)	1235-0023
(a)(3)(i)	1235-0023
(a)(3)(ii)(A)	1235-0023
	1235-0008
(c)	1235-0023

[48 FR 19540, Apr. 29, 1983, as amended at 51 FR 12265, Apr. 9, 1986; 55 FR 50150, Dec. 4, 1990; 57 FR 28776, June 26, 1992; 58 FR 58955, Nov. 5, 1993; 61 FR 40716, Aug. 5, 1996; 65 FR 69693, Nov. 20, 2000; 73 FR 77511, Dec. 19, 2008; 81 FR 43450, July 1, 2016; 82 FR 2225, 2226, Jan. 9, 2017; 83 FR 12, Jan 2, 2018; 84 FR 218, Jan. 23, 2019; 87 FR 2334, Jan. 14, 2022; 88 FR 2215, Jan. 13, 2023; 88 FR 57734, Aug. 23, 2023; 89 FR 1815, Jan. 11, 2024]

"General Decision Number: OK20240049 01/12/2024

Superseded General Decision Number: OK20230049

State: Oklahoma

Construction Type: Building

Building Construction -does not include residential construction consisting of single family homes and apartments up to and including 4 stories. (Including building projects on industrial sites and treatment plants)

County: Oklahoma County in Oklahoma.

Note: Contracts subject to the Davis-Bacon Act are generally required to pay at least the applicable minimum wage rate required under Executive Order 14026 or Executive Order 13658. Please note that these Executive Orders apply to covered contracts entered into by the federal government that are subject to the Davis-Bacon Act itself, but do not apply to contracts subject only to the Davis-Bacon Related Acts, including those set forth at 29 CFR 5.1(a)(1).

If the contract is entered into on or after January 30, 2022, or the contract is renewed or extended (e.g., an option is exercised) on or after January 30, 2022:	. Executive Order 14026 generally applies to the contract.	The contractor must pay all covered workers at least \$17.20 per hour (or the applicable wage rate listed on this wage determination, if it is higher) for all hours spent performing on the contract in 2024.
---	--	--

If the contract was awarded on or between January 1, 2015 and January 29, 2022, and the contract is not renewed or extended on or after January 30, 2022:	. Executive Order 13658 generally applies to the contract.	The contractor must pay all covered workers at least \$12.90 per hour (or the applicable wage rate listed on this wage determination, if it is higher) for all hours spent performing on that contract in 2024.
---	--	---

The applicable Executive Order minimum wage rate will be adjusted annually. If this contract is covered by one of the

Executive Orders and a classification considered necessary for performance of work on the contract does not appear on this wage determination, the contractor must still submit a conformance request.

Additional information on contractor requirements and worker protections under the Executive Orders is available at <http://www.dol.gov/whd/govcontracts>.

Modification Number	Publication Date
0	01/05/2024
1	01/12/2024

BROK0005-004 06/01/2023

	Rates	Fringes
BRICKLAYER.....	\$ 26.92	13.09

CARP0216-002 01/01/2023

	Rates	Fringes
MILLWRIGHT.....	\$ 29.75	11.83

CARP0329-003 01/01/2022

	Rates	Fringes
CARPENTER (Form Work Only).....	\$ 24.15	10.15

ELEC1141-010 09/04/2023

	Rates	Fringes
ELECTRICIAN (Excludes Low Voltage Wiring and Installation of Alarms).....	\$ 37.85	17.25%+6.00

ELEC1141-030 06/01/2019

	Rates	Fringes
ELECTRICIAN (Low Voltage Wiring Only).....	\$ 21.60	15.5%+8.60

ELEV0063-004 01/01/2023

	Rates	Fringes
ELEVATOR MECHANIC.....	\$ 46.83	37.335+a+b

PAID HOLIDAYS:

a. New Year's Day, Memorial Day, Independence Day, Labor Day, Veteran's Day, Thanksgiving Day, the Friday after Thanksgiving, and Christmas Day.

b. Employer contributes 8% of regular hourly rate to vacation pay credit for employee who has worked in business more than 5 years; 6% for less than 5 years' service.

* ENGI0627-023 06/01/2023

Rates Fringes

POWER EQUIPMENT OPERATOR:

Group 1.....	\$ 35.65	16.50
Group 2.....	\$ 33.80	16.50
Group 3.....	\$ 33.10	16.50
Group 4.....	\$ 31.95	16.50
Group10.....	\$ 25.45	16.50

POWER EQUIPMENT OPERATOR

*Effective first full pay period after June 1, 2021

GROUP 1: All Crane Type Equipment 200 ton and larger and including 400 ton capacity cranes. Including all Overhead crane types.

#Crances over 400 tons up to and including 500 tons add additional \$.75 per hour.

##Cranes over 500 tons and up to and including 700 tons ass an additional \$1.50 per hour.

###Cranes over 700 tons shall add additional \$3.00 per hour.

All Tower Cranes

GROUP 2: All Crane Type Equipment 100 ton capacity and larger cranes, and less than 200 ton capacity, including all Overhead cranes types.

GROUP 3: All Crane Type Equipment 50 ton capacity and larger cranes, and less than 100 ton capacity, including all Overhead cranes types.

Cranes Equipment (as rated by mfg.) 3 cu.yd. and over Guy derrick, Whirley, Power Driven Hole Digger (with 30' and longer mast) Excavator, Backhoe, Motor Patrol (Blade).

GROUP 4: Cranes with less than 50 ton capacity and Cranes (as rated by mfg.) less than 3cu. yd., including all Overhead Crans types, Goldhofer/Modular Powered Trailer, Mobile Gantry System, Heavy Duty Mechanic, Welder Overhead Monorail Types Crane, Panel Board Batch, Plant Operator, Piledriver Engineer, Dragline, Clamshell Sideboom or similar type equipment, Gradall, Cherry Picker, Hosit (while operating 2 or more dums); All Hoist (while doing stack and chimney work) Power Driven Hole digger with less

than 30' mast. Vacuum Truck, Dozer, Loader or High Lift
(Track Loader-not Skidsteer type)

GROUP 10: TrucK Crane Oiler and Driver, Crane Oiler,
Permanent Building Type Elevator Operator, Oiler/ Assisnat
Engineers no Certification or less certification than any
above group.

IRON0048-014 06/01/2021

Rates Fringes

IRONWORKER (Ornamental and
Structural).....\$ 29.00 16.20

PLUM0344-006 07/01/2023

Rates Fringes

PLUMBER (Excludes HVAC Pipe
Installation).....\$ 38.25 15.54

PLUM0344-019 07/01/2023

Rates Fringes

HVAC MECHANIC (Installation
of HVAC Unit Only, Excludes
Installation of HVAC Pipe and
Duct).....\$ 38.25 15.54

PLUM0344-024 07/01/2023

Rates Fringes

PIPEFITTER (Including HVAC
Pipe Installation).....\$ 38.25 15.54

ROOF0143-001 07/31/2023

Rates Fringes

ROOFER.....\$ 25.30 9.50

* SFOK0669-002 01/01/2024

Rates Fringes

SPRINKLER FITTER (Fire
Sprinklers).....\$ 36.54 25.72

SHEE0124-010 07/01/2021

Rates Fringes

SHEET METAL WORKER (HVAC Duct
Installation Only).....\$ 33.38 16.36

* SUOK2012-029 07/30/2012

Rates Fringes

CARPENTER (Acoustical Ceiling
Installation Only).....\$ 14.98 ** 0.00

CARPENTER, Excludes
Acoustical Ceiling
Installation, Drywall
Hanging, Form Work, and Metal
Stud Installation.....\$ 16.61 ** 3.00

CEMENT MASON/CONCRETE FINISHER...\$ 16.75 ** 0.00

DRYWALL FINISHER/TAPER.....\$ 13.74 ** 0.00

DRYWALL HANGER, Includes
Metal Stud Installation.....\$ 14.38 ** 0.00

ELECTRICIAN (Alarm
Installation).....\$ 20.97 5.22

FENCE ERECTOR.....\$ 14.00 ** 0.00

GLAZIER.....\$ 12.02 ** 2.42

IRONWORKER, REINFORCING.....\$ 17.11 ** 0.00

LABORER: Common or General.....\$ 11.70 ** 0.00

LABORER: Landscape.....\$ 13.75 ** 0.00

LABORER: Mason Tender - Brick...\$ 12.00 ** 0.00

LABORER: Mason Tender -
Cement/Concrete.....\$ 13.00 ** 1.91

LABORER: Pipelayer.....\$ 12.39 ** 0.00

LABORER: Plaster Tender.....\$ 11.00 ** 0.00

OPERATOR:
Backhoe/Excavator/Trackhoe.....\$ 21.25 4.35

OPERATOR: Bulldozer.....\$ 20.64 2.35

OPERATOR: Forklift.....\$ 20.55 0.00

OPERATOR: Grader/Blade.....	\$ 14.28 **	1.70
OPERATOR: Loader (Front End)....	\$ 16.18 **	0.00
OPERATOR: Paver (Asphalt, Aggregate, and Concrete).....	\$ 13.38 **	1.54
PAINTER: Brush, Roller and Spray, Excludes Drywall Finishing/Taping.....	\$ 12.42 **	0.00
PLASTERER.....	\$ 16.10 **	0.00
SHEET METAL WORKER, Excludes HVAC Duct Installation.....	\$ 17.57	4.64
TRUCK DRIVER: Dump and Flatbed Truck.....	\$ 11.60 **	0.00

WELDERS - Receive rate prescribed for craft performing operation to which welding is incidental.

=====

** Workers in this classification may be entitled to a higher minimum wage under Executive Order 14026 (\$17.20) or 13658 (\$12.90). Please see the Note at the top of the wage determination for more information. Please also note that the minimum wage requirements of Executive Order 14026 are not currently being enforced as to any contract or subcontract to which the states of Texas, Louisiana, or Mississippi, including their agencies, are a party.

Note: Executive Order (EO) 13706, Establishing Paid Sick Leave for Federal Contractors applies to all contracts subject to the Davis-Bacon Act for which the contract is awarded (and any solicitation was issued) on or after January 1, 2017. If this contract is covered by the EO, the contractor must provide employees with 1 hour of paid sick leave for every 30 hours they work, up to 56 hours of paid sick leave each year. Employees must be permitted to use paid sick leave for their own illness, injury or other health-related needs, including preventive care; to assist a family member (or person who is like family to the employee) who is ill, injured, or has other health-related needs, including preventive care; or for reasons resulting from, or to assist a family member (or person who is like family to the employee) who is a victim of, domestic violence, sexual assault, or stalking. Additional information on contractor requirements and worker protections under the EO is available at <https://www.dol.gov/agencies/whd/government-contracts>.

Unlisted classifications needed for work not included within

the scope of the classifications listed may be added after award only as provided in the labor standards contract clauses (29CFR 5.5 (a) (1) (iii)).

The body of each wage determination lists the classification and wage rates that have been found to be prevailing for the cited type(s) of construction in the area covered by the wage determination. The classifications are listed in alphabetical order of ""identifiers"" that indicate whether the particular rate is a union rate (current union negotiated rate for local), a survey rate (weighted average rate) or a union average rate (weighted union average rate).

Union Rate Identifiers

A four letter classification abbreviation identifier enclosed in dotted lines beginning with characters other than ""SU"" or ""UAVG"" denotes that the union classification and rate were prevailing for that classification in the survey. Example: PLUM0198-005 07/01/2014. PLUM is an abbreviation identifier of the union which prevailed in the survey for this classification, which in this example would be Plumbers. 0198 indicates the local union number or district council number where applicable, i.e., Plumbers Local 0198. The next number, 005 in the example, is an internal number used in processing the wage determination. 07/01/2014 is the effective date of the most current negotiated rate, which in this example is July 1, 2014.

Union prevailing wage rates are updated to reflect all rate changes in the collective bargaining agreement (CBA) governing this classification and rate.

Survey Rate Identifiers

Classifications listed under the ""SU"" identifier indicate that no one rate prevailed for this classification in the survey and the published rate is derived by computing a weighted average rate based on all the rates reported in the survey for that classification. As this weighted average rate includes all rates reported in the survey, it may include both union and non-union rates. Example: SULA2012-007 5/13/2014. SU indicates the rates are survey rates based on a weighted average calculation of rates and are not majority rates. LA indicates the State of Louisiana. 2012 is the year of survey on which these classifications and rates are based. The next number, 007 in the example, is an internal number used in producing the wage determination. 5/13/2014 indicates the survey completion date for the classifications and rates under that identifier.

Survey wage rates are not updated and remain in effect until a new survey is conducted.

Union Average Rate Identifiers

Classification(s) listed under the UAVG identifier indicate that no single majority rate prevailed for those classifications; however, 100% of the data reported for the classifications was union data. EXAMPLE: UAVG-OH-0010 08/29/2014. UAVG indicates that the rate is a weighted union average rate. OH indicates the state. The next number, 0010 in the example, is an internal number used in producing the wage determination. 08/29/2014 indicates the survey completion date for the classifications and rates under that identifier.

A UAVG rate will be updated once a year, usually in January of each year, to reflect a weighted average of the current negotiated/CBA rate of the union locals from which the rate is based.

WAGE DETERMINATION APPEALS PROCESS

1.) Has there been an initial decision in the matter? This can be:

- * an existing published wage determination
- * a survey underlying a wage determination
- * a Wage and Hour Division letter setting forth a position on a wage determination matter
- * a conformance (additional classification and rate) ruling

On survey related matters, initial contact, including requests for summaries of surveys, should be with the Wage and Hour National Office because National Office has responsibility for the Davis-Bacon survey program. If the response from this initial contact is not satisfactory, then the process described in 2.) and 3.) should be followed.

With regard to any other matter not yet ripe for the formal process described here, initial contact should be with the Branch of Construction Wage Determinations. Write to:

Branch of Construction Wage Determinations
Wage and Hour Division
U.S. Department of Labor
200 Constitution Avenue, N.W.
Washington, DC 20210

2.) If the answer to the question in 1.) is yes, then an interested party (those affected by the action) can request

review and reconsideration from the Wage and Hour Administrator (See 29 CFR Part 1.8 and 29 CFR Part 7). Write to:

Wage and Hour Administrator
U.S. Department of Labor
200 Constitution Avenue, N.W.
Washington, DC 20210

The request should be accompanied by a full statement of the interested party's position and by any information (wage payment data, project description, area practice material, etc.) that the requestor considers relevant to the issue.

3.) If the decision of the Administrator is not favorable, an interested party may appeal directly to the Administrative Review Board (formerly the Wage Appeals Board). Write to:

Administrative Review Board
U.S. Department of Labor
200 Constitution Avenue, N.W.
Washington, DC 20210

4.) All decisions by the Administrative Review Board are final.

END OF GENERAL DECISION"