

NOTICE TO BIDDERS

Notice is given that the Midwest City Municipal Authority, a public trust, will receive sealed bids in the office of the Secretary, Midwest City Municipal Center, 100 N. Midwest Boulevard, Midwest City, Oklahoma, until 2:00p.m., Tuesday October 24, 2023, for:

MOVING BED BIOFILM REACTOR (MBBR) CLEANING AND MEDIA INSTALLATION

Any bids received more than ninety-six (96) hours, excluding Saturdays, Sundays, and holidays, before the time set for opening of bids, as well as bids received after 2:00 p.m. on the above date will be returned unopened. Bids shall be made in accordance with the bid documents, all of which are on file and available for public examination in the office of the secretary in the Midwest City Municipal Center. Complete sets of bid documents may be obtained from the City of Midwest City, Public Works Administration, 8730 SE 15th, Midwest City, Oklahoma 73110.

Bids filed with the Secretary shall be opened publicly and read aloud in the City Council Chambers at the time stated above or later. All bids shall be considered by the Chairman and Trustees of the Municipal Authority prior to the contract being awarded. The Municipal Authority shall consider award of the bid at or after 6:00 pm on November 14, 2023, to the lowest and best bidder meeting specifications. The Municipal Authority may lay the same over to a subsequent meeting for comparison and computation.

The bidder shall use the Municipal Authority bid documents only and all forms must be signed and notarized/attested. The bidder shall file his/her bid in a sealed envelope. Each envelope shall bear a legible notation thereon that it is a bid upon the item proposed. The bid shall be filed with the Secretary in the City Clerk's office. All bids shall be typewritten or in ink.

The specifications are complete as written. No oral representations made by any agent or employee of the Municipal Authority or its affiliate agencies shall be of any force or effect unless reduced to writing and submitted to all prospective bidders at least 24 hours in advance of the bid opening.

Any protest of the award of this proposed contract shall be in writing, shall specify the grounds for the protest in specific terms and shall be received by the Secretary/City Clerk within three (3) business days after the award of the contract by the governing body. The governing body reserves the right to review all bids and make the award to the lowest and best bidder. All other provisions of the specifications shall also apply.

The bidder may attend the non-mandatory, virtual pre-bid conference at 1:00 PM on October 10, 2023. Bidders wishing to attend the pre-bid conference or in need of additional information should contact the City of Midwest City, Public Works Department, **Carrie Evenson, Assistant Public Works Director, Public Works Department, 8730 SE 15th, Midwest City, Oklahoma 73110, (405) 739-1062, cevenson@midwestcityok.org**.

The Chairman and Trustees of the Midwest City Municipal Authority reserves the right to reject any or all bids.



Sara Hancock, Secretary
Midwest City Municipal Authority

Invitation for Sealed Bids

MIDWEST CITY MUNICIPAL AUTHORITY

100 N. MIDWEST BLVD.
MIDWEST CITY, OKLAHOMA 73110

Write legibly in ink or use typewriter.

Published In
Journal Record

Dates Advertised
Tuesday, October 3, 2023
Tuesday, October 17, 2023

Bids must be in the Office of the City Clerk By:
Tuesday, October 24, 2023 no later than 2:00 p.m.

IMPORTANT: Bid envelope must indicate bid item enclosed and date of bid opening.

	Description	Days	Labor (\$/day)	Contractor Supplied Material (\$)	Equipment (\$/day)	Total (\$)
1	West Reactor Drainage and Cleaning					
2	Pilot installation					
3	Bid Price (Totals)					

THE MIDWEST CITY MUNICIPAL AUTHORITY IS EXEMPT FROM PAYMENT OF OKLAHOMA SALES TAX AND FEDERAL EXCISE TAX.

I have examined the specifications and agree, provided I am awarded a contract within thirty (30) days from the date fixed for opening bids, to provide the above described items for the sum shown, in accordance with the terms and conditions attached to this sheet as "Agreement By Bidder."

REPLACEMENT WILL BE COMPLETED IN _____ DAYS OR LESS FROM DATE OF ORDER. DATED THIS _____ DAY OF _____, 2023.

FIRM _____ BY _____

ADDRESS _____ TITLE _____

Accepted by the MIDWEST CITY MUNICIPAL AUTHORITY this _____ day of _____, 2023

MATTHEW D. DUKES, II, Chairman

SARA HANCOCK, Secretary

Approved as to form this _____ day of _____, 2023.

DON MAISCH, City Attorney

AGREEMENT BY BIDDER

THESE TERMS APPLY TO AND BECOME PART OF THE TERMS AND CONDITIONS OF BID. ANY EXCEPTION MUST BE IN WRITING.

1. Bids must be submitted on the attached form only. Each bid must be placed in a separate envelope. Each envelope must be completely and properly identified and sealed, showing the date of bid opening and the subject advertised.
2. The Midwest City Municipal Authority reserves the right to reject any and all bids, to waive any technicalities in the bidding, and to award each item to different bidders or all items to a single bidder.
3. No bidder may withdraw his bid within a period of thirty (30) days after the date and hour set for the opening of bids. A bidder may withdraw his bid at any time prior to the time fixed for the opening of bids.
4. All bids must be accompanied by bidder's bond or cashier's check in the amount shown on the Invitation for Sealed Bids form when required by the Midwest City Municipal Authority. This amount may be retained by the Midwest City Municipal Authority as liquidated damages in the event the successful bidder (or bidders) fails to comply with the terms of this bid. The Secretary will return the deposits to the unsuccessful bidders after the contract has been awarded.
5. All prices shall be quoted F.O.B. Midwest City, Oklahoma, and delivery to Midwest City Municipal Authority location shall be without additional charges unless otherwise stated in specifications.
6. The bidder shall attach the manufacturer's name of the equipment or materials to be furnished, type, model numbers, manufacturer's descriptive bulletins and specifications. All guarantees and warranties must be clearly stated. This data shall be in sufficient detail to describe accurately the equipment or material to be furnished. Manufacturer's specifications in respect to the successful bidder shall be considered as part of his contract with the Midwest City Municipal Authority.
7. The bidder shall show in the bid both the unit prices and total amount, where required, of each item listed. In the event of error or discrepancy in the mathematics, the unit prices shall prevail.
8. Any exceptions to these items or conditions or deviations from written specifications shall be shown in writing and attached to the bid form.
9. In the event cash discounts are offered by the bidder, the discount date should begin with the date of invoice or the date of receipt of all material covered by the purchase order.
10. The bidder's attention is directed to the fact that the purchase of certain items of equipment or material by the Midwest City Municipal Authority is exempt from Federal Excise Tax. In such cases, the bidder shall quote prices, which do not include Federal Excise Tax. The Midwest City Municipal Authority will execute exemption certificates upon presentation by the bidder at the time of purchase.
11. Information to bidders and specifications are on file in the office of the Secretary and copies may be obtained from the Municipal Building, 100 N. Midwest Blvd., Midwest City, Oklahoma.
12. Bids must show number of days required for delivery under normal conditions. Failure to state delivery time obligates bidder to complete delivery in fourteen (14) calendar days. Unrealistically short or long delivery promises may cause bid to be disregarded. Bidder must keep Purchase Department advised at all times of status of order. Default in promised delivery or failure to meet specifications authorizes the Midwest City Municipal Authority to purchase bid items elsewhere and charge full increase of cost and handling to defaulting contractor. Consistent failure to meet delivery promises without valid reason may cause removal from bid list.
13. Bidder agrees to defend and save the Midwest City Municipal Authority harmless from and against all demands, claims, suits, costs expenses, damages and judgments based upon infringement of any patent relating to goods specified in this order or the ordinary use or operation of such goods by the City or use or operation of such goods in accordance with bidder's direction.
14. Bidder may bid on one or all items but bids may not be tied together unless specifically stated in specifications.
15. The specifications are complete as written. No oral representation made by any agent or employee of the Municipal Authority, or its affiliate agencies, shall be of any force or effect unless reduced to writing and submitted to all prospective bidders at least 24 hours in advance of the bid opening.
16. Any protest of the award of this proposed contract by a bidder on the contract shall be in writing, shall specify the grounds for the protest in specific terms and shall be received by the Secretary/City Clerk within three (3) business days after the award of the contract by the governing body. All other provisions of these specifications shall also apply.
17. Each bidder when affixing his signature to the "Invitation for Sealed Bids" states that he has not, directly or indirectly, entered into any agreement, express or implied, with any other bidder or bidders, having for its object the controlling of the price, or amount of such bids, the limiting of the bids of bidders or the paying to any one any money for promotion expenses. the parceling or farming out to any bidder or bidders or other persons of any part of the contract or any part of the subject matter of the bid or the profits thereof.

No bidder shall divulge the information in his sealed bid to any person whomsoever, except those having a partnership or other financial interest with him in said bid, until after the sealed bids are opened.

A violation of any one of the foregoing provisions on the part of a bidder shall be sufficient reason for the rejection of his bid or making void any contract made by him with the City based upon such bid.

NON COLLUSION AFFIDAVIT

STATE OF _____)

SS.

COUNTY OF _____)

_____, of lawful age, being first duly sworn, on oath says that (s) he is the agent authorized by the bidder to submit the attached bid. Affiant further states that the bidder has not been a party to any collusion among bidders in restraint of freedom of competition by agreement to bid at a fixed price or to refrain from bidding; or with any City or Municipal Authority official or employee as to quantity, quality, or price in the prospective contract, or any other prospective contract; or in any discussions between bidders and any City or Municipal City official concerning exchange of money or other things of value for special consideration in the letting of the prospective contract.

Subscribed and sworn to before me this _____ day of _____, 2023

Notary Public

My Commission Expires:

Contractor Certification

Contractor certifies and warrants that it will comply with the Immigration Laws of the United States, including but not limited to 8 USC 1324(a), which makes it unlawful for an employer to hire or continue to employ an illegal or undocumented alien *knowing* the alien is or has become unauthorized with respect to such employment, or to fail to comply with the I-9 requirements. Contractor further agrees to comply with the Oklahoma Taxpayer and Citizen Protection Act of 2007. Contractor will not knowingly employ or knowingly allow any of its Subcontractors to employ any illegal or undocumented aliens to perform any work in connection with services performed for the Midwest City Municipal Authority. After July 1, 2008, Contractor and its Subcontractors will verify information on all new employees on the Status Verification System operated by the U.S. Government.

Contractor will retain and make available for inspection by the Municipal Authority, upon reasonable notice, a completed I-9 Employment Eligibility Verification Form for each person that contractor directly employs to perform services for the Midwest City Municipal Authority. If Contractor, or any of its Subcontractors, receives *actual knowledge* of the unauthorized status of one of its employees engaged in providing services to the Municipal Authority, then Contractor or Subcontractor will remove that employee from the project, and shall require each Sub-contractor to act in a similar fashion with respect to such Sub-contractor's employees. Contractor agrees to have a provision in its subcontracts stating that each Sub-contractor will have the same duties and responsibilities with regard to its employees that the Contractor has certified in this paragraph.

Signed under penalty of perjury on _____, 2023.

_____,
Contractor

By: _____
Owner or Authorized Officer

MOVING BED BIOREACTOR (MBBR) TASKS TO BE PERFORMED

GENERAL:

The purpose of these specifications is to qualify and describe the work to be performed at the Moving Bed Bioreactor (MBBR) for the Midwest City Municipal Authority.

Bid Package:

1. All bid submittal documents shall be submitted as a single package in a sealed envelope.
2. All bid packages must include a non-collusion affidavit, contractor certification, a fully completed bid form (see page 4 of this document), and the following information:
 - A. A proposed schedule of the executed work with respect to the major tasks outlined in the Summary of Work
 - B. A list of at least three current, domestic wastewater facilities where previous work has been performed, including contact information.
3. Submittals which do not have all of the information required for evaluation will not be reviewed or considered.

Method of Payment:

Contractor to submit monthly pay applications detailing percentage of the work that has been completed.

Summary of Work:

- A. Work of the Project includes cleaning the West Reactors and installing two WavTex modules. More specifically, the Work includes, but is not limited to, the following:
 - 1. Basin Drainage and Cleaning
 - a. Contractor shall pump down the content of the West Reactors (1-6) using a Contractor provided pump to one (1) foot above the tank floor. Contractor shall pump the content into the East Reactors. Pumping rate shall not exceed 750 gpm.
 - b. Contractor shall remove all remaining liquid and solid material from the West Reactors (1-6) and pump it into the adjacent sanitary sewer system detailed in Appendix A. Contractor shall document the depth of the solids in each reactor.
 - c. Contractor shall wash the walls, floors, and screens of the West Reactors with a firehose to remove attached solids. Screens should be completely free of detritus after cleaning, Contractor shall pressure wash or manually clean if necessary. Wash water shall be pumped to the manhole indicated in Appendix A at a rate not to exceed 750 gpm.
 - d. Contractor shall inspect and document, with photos, the condition of the screens separating the West Reactors.
 - 2. Pilot WavTex Module System
 - a. Contractor shall provide aeration piping, fittings, and supports shown in Appendix B and Appendix C for a complete installation of the pilot equipment as detailed in Appendices B, and C.
 - b. Contractor shall install Owner provided pilot modules per manufacturers recommendations (Appendix C) in West Reactors No. 2 and No. 3 and connect them to existing air piping.

Attachments:

Appendix A – Sanitary Sewer Manhole Location

Appendix B – Pilot Module and Aeration Piping Drawings

Appendix C – Entex General Contractor Support Document

Submittals:

1. The total quantity of pipe provided by the Contractor for aeration shall be detailed in a submittal and include the specific pipe material, pipe diameter, and length in linear feet. Also include any specifications or details on hardware used to connect piping sections.
2. The number of anchor bolts described in Appendix B. Including the specifications of anchor bolt/epoxy system for anchoring the WavTex Modules per Appendix C.
3. The number and location of piping supports to be used, as well as the anchor bolt information for piping supports.
4. Specifications of the pump(s) used to drain Western MBBR Zones and convey solids.

Warranty:

For the WavTex Media installation, provide a 1-year warranty against breakage or tearing during handling and installation of the WavTex.

Location of Work to be performed:

Midwest City Water Resources Recovery Facility, 7420 NE 36th St, Oklahoma City, OK 73141.

Execution of Work to be Performed:

Once awarded, mobilization and execution of the Work shall begin no later than 90 days from the notice to proceed. Work is to be performed as necessary, but regular working hours 7:00 am to 5:00 pm are preferred. Work is not to be performed on City recognized holidays. A list of the holidays is available upon request.

MBBR Modifications

Bid Form Including Work Plan and Pricing

1. Work Completion. If your bid is accepted and a contract is executed, state the number of days you need to complete the work after the Notice to Proceed: _____

You must be able to perform the services as specified in your bid. Failure to do so may result in City terminating your contract or canceling the Purchase Order.

2. Pricing

1. Bidders shall provide prices of all items. Bid prices will be based on the summary of work and quantities shown in Form A - Pricing of this IFB.
2. All charges anticipated by the bidder to meet these specifications must be included. No additional charges will be allowed.

Cost of tasks to be performed.

	Description	Days	Labor (\$/day)	Contractor Supplied Material (\$)	Equipment (\$/day)	Total (\$)
1	West Reactor Drainage and Cleaning					
2	Pilot installation					
3	Bid Price (Totals)					

Contractor: _____

Contact: _____

Address: _____

City, State & Zip: _____

Phone: _____

Email Address: _____

APPENDIX [A]

Sanitary Sewer Manhole Location

Appendix A - Sanitary Sewer Manhole Location

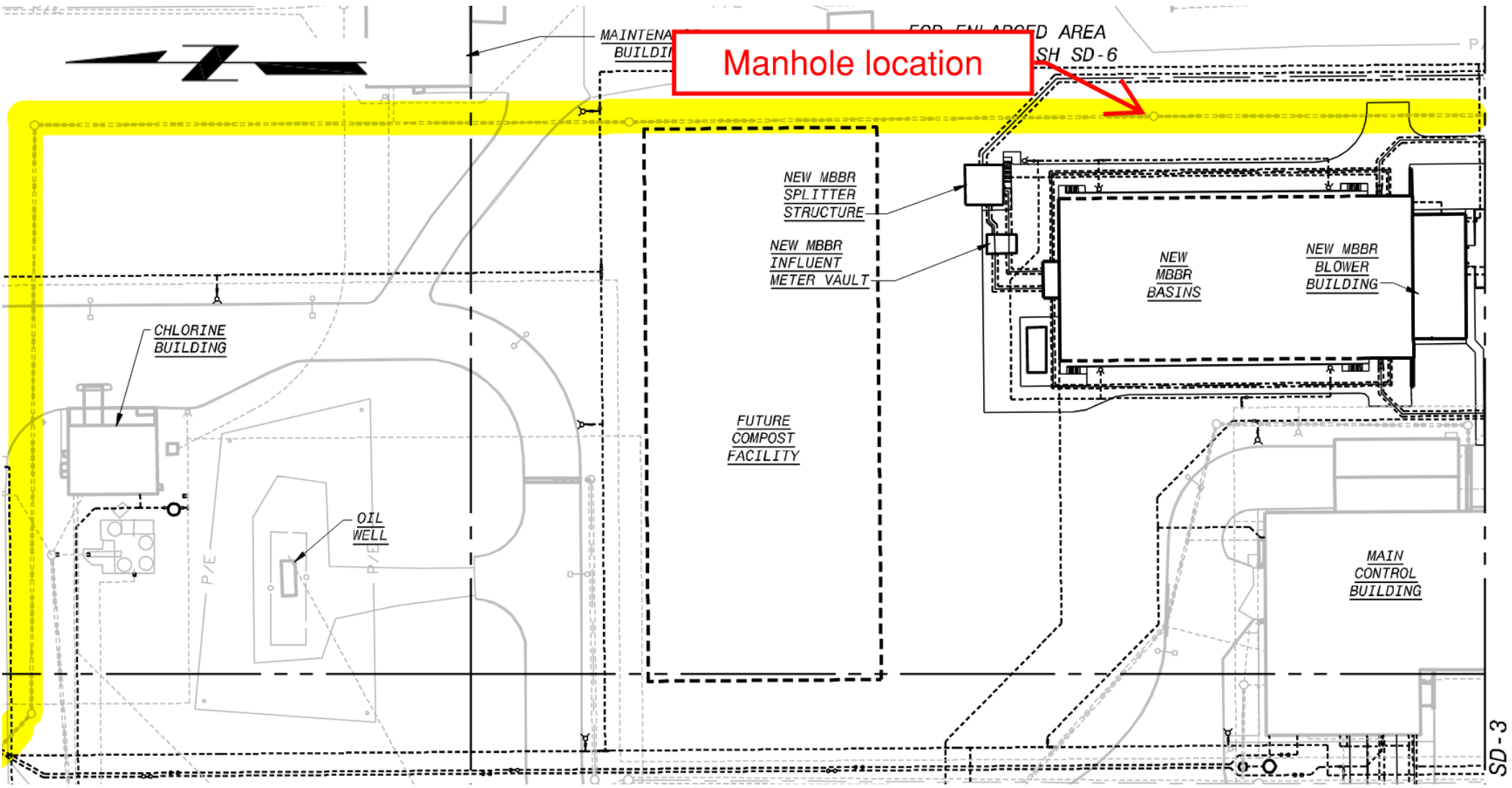

Manhole location

MAINTENANCE BUILDING

FOR ENLARGED AREA
SH SD-6

NEW MBBR
SPLITTER
STRUCTURE

NEW MBBR
INFLUENT
METER VAULT

NEW MBBR
BASINS

NEW MBBR
BLOWER
BUILDING

CHLORINE
BUILDING

OIL
WELL

FUTURE
COMPOST
FACILITY

MAIN
CONTROL
BUILDING

SD-3

APPENDIX [B]

Pilot Module and Aeration Piping Drawings

NOTES:

- EXHIBITS SHOW GENERAL LAYOUT OF THE WORK ONLY, CONTRACTOR IS RESPONSIBLE FOR INSTALLING PILOT EQUIPMENT PER MANUFACTURERS RECOMMENDATIONS AND PROVIDING NECESSARY PIPING, FITTINGS, AND SUPPORTS TO PLACE PILOTS INTO OPERATION.

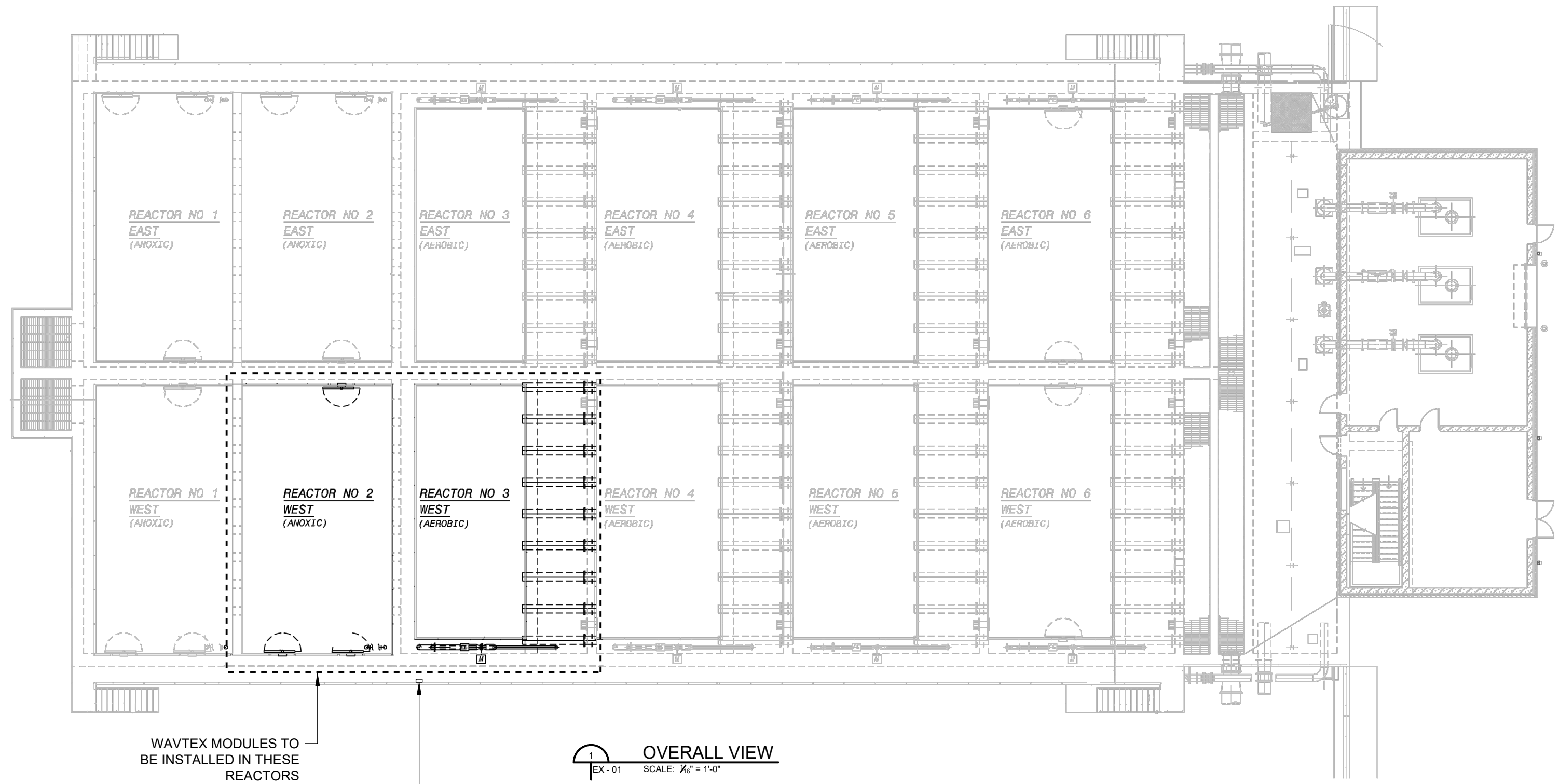

WAVTEX MODULES TO BE INSTALLED IN THESE REACTORS

REACTOR 2 LIGHTING PANEL

1
EX - 01 **OVERALL VIEW**
SCALE: 1/16" = 1'-0"

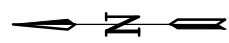

© 2023 GARVER, LLC. THIS DOCUMENT, ALONG WITH THE IDEAS AND DESIGNS CONVEYED HEREIN, SHALL BE CONSIDERED INSTRUMENTS OF PROFESSIONAL SERVICE AND ARE PROPERTY OF GARVER, LLC. ANY USE, REPRODUCTION, OR DISTRIBUTION OF THIS DOCUMENT, ALONG WITH THE IDEAS AND DESIGN CONTAINED HEREIN, IS PROHIBITED UNLESS AUTHORIZED IN WRITING BY GARVER, LLC OR EXPLICITLY ALLOWED IN THE GOVERNING PROFESSIONAL SERVICES AGREEMENT FOR THIS WORK.

<p>THE CITY OF MIDWEST CITY MIDWEST CITY, OK MIDWEST CITY WWTP EVALUATION</p>	<p>OVERALL VIEW</p>	<p>REV DATE DESCRIPTION BY</p> <p>EXHIBIT NUMBER EX - 01</p>	
<p>JOB NO.: 22W02170</p>	<p>DATE: 07/18/2023</p>		

NOTES:

1. CONTRACTOR SHALL INSTALL OWNER SUPPLIED PILOT MODULES IN REACTORS AND CONNECT TO EXISTING AIR PIPING.
2. ALL PIPE SUPPORTS, ANCHOR BOLTS, AND OTHER HARDWARE SHALL BE 304 SST.

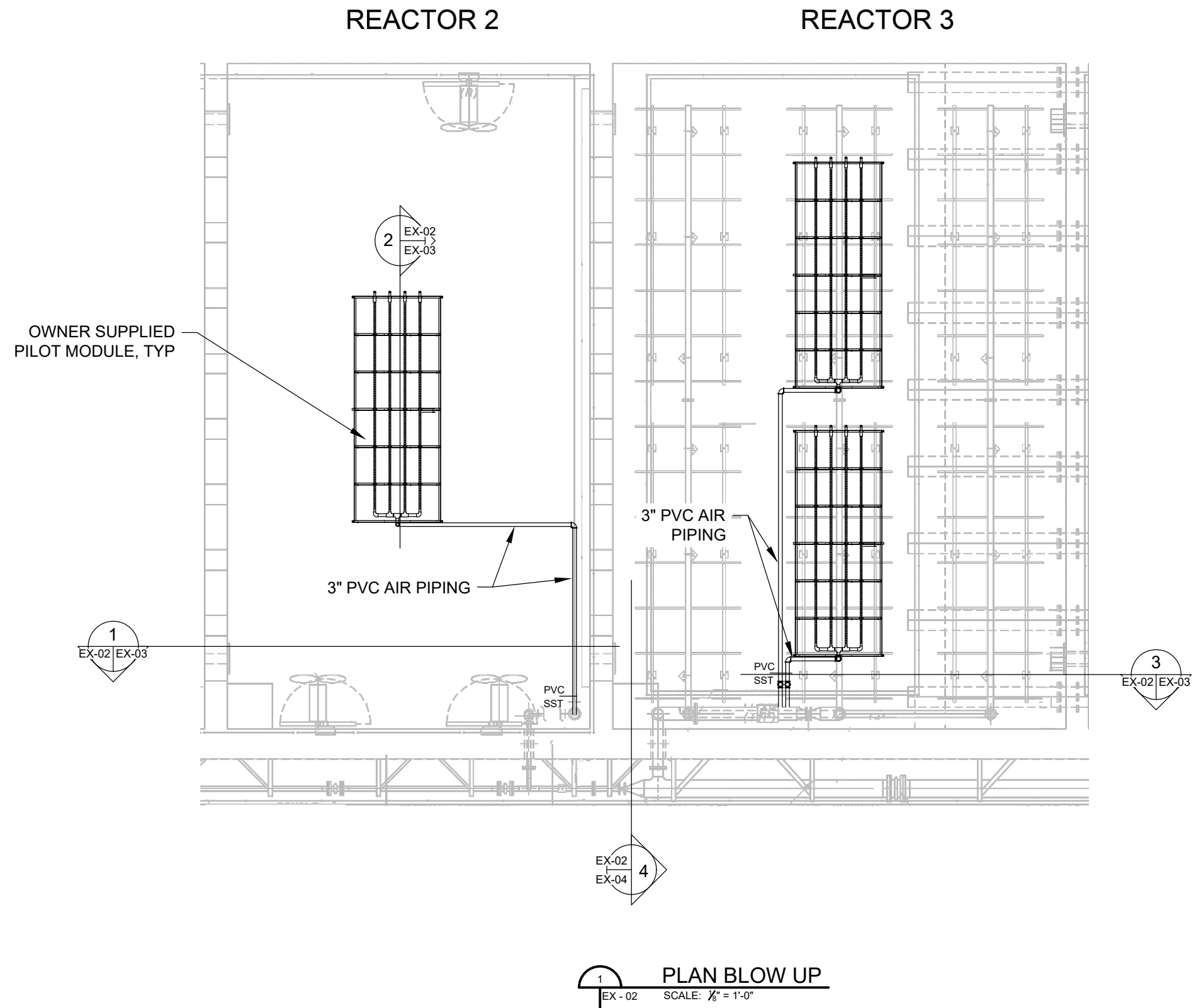

© 2023 GARVER, LLC. THIS DOCUMENT, ALONG WITH THE IDEAS AND DESIGNS CONVEYED HEREIN, SHALL BE CONSIDERED INSTRUMENTS OF PROFESSIONAL SERVICE AND ARE PROPERTY OF GARVER, LLC. ANY USE, REPRODUCTION, OR DISTRIBUTION OF THIS DOCUMENT, ALONG WITH THE IDEAS AND DESIGN CONTAINED HEREIN, IS PROHIBITED UNLESS AUTHORIZED IN WRITING BY GARVER, LLC OR EXPLICITLY ALLOWED IN THE GOVERNING PROFESSIONAL SERVICES AGREEMENT FOR THIS WORK.

THE CITY OF MIDWEST CITY
 MIDWEST CITY, OK
MIDWEST CITY
WWTP EVALUATION

ENLARGED PLAN

EXHIBIT NUMBER
EX - 02

JOB NO.: 22W02170

DATE: 07/18/2023

REV	DATE	DESCRIPTION	BY



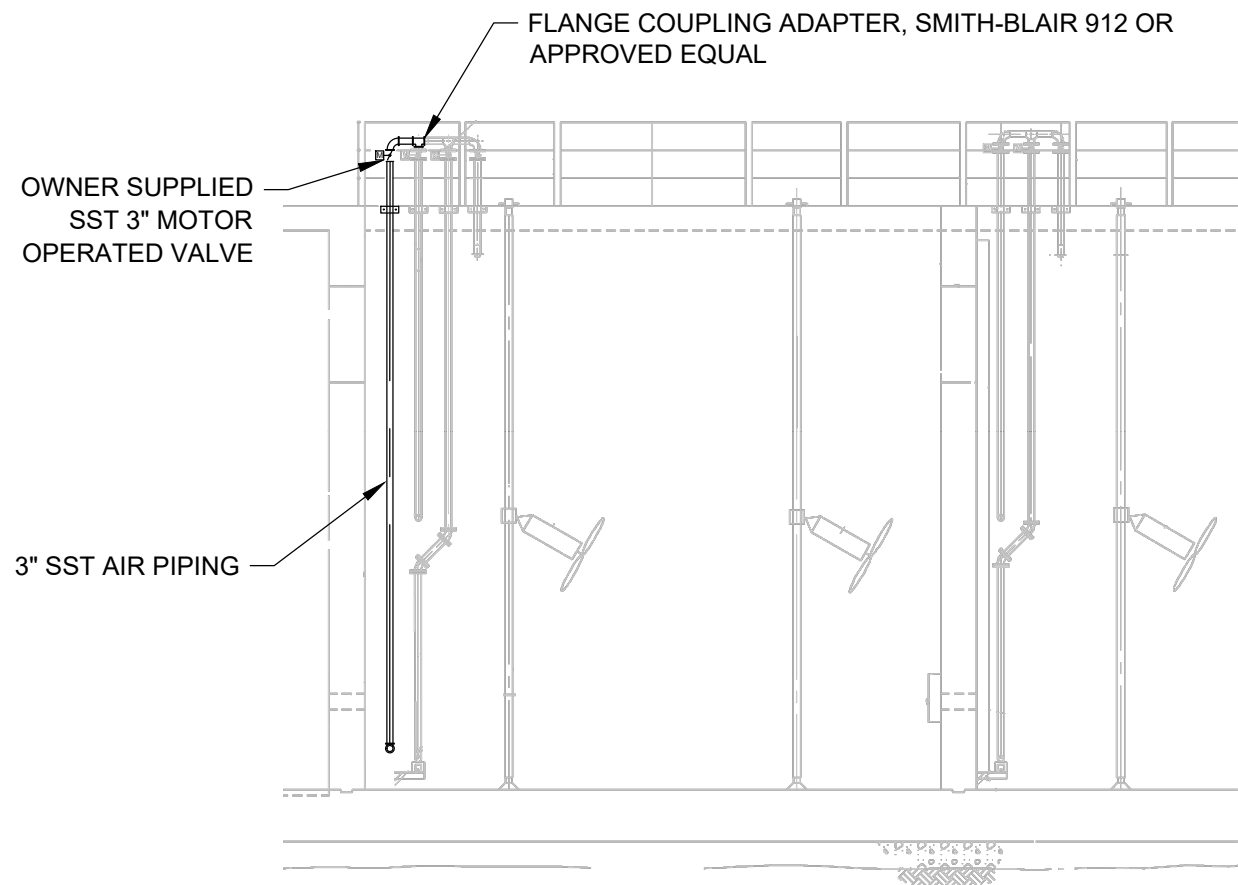

NOTES:

1. CONTRACTOR SHALL INSTALL OWNER SUPPLIED ENCLOSURE AND ELECTRICAL COMPONENTS AS SHOWN ON EX-05. POWER FROM REACTOR 2 WEST LIGHTING PANEL.
2. CONTRACTOR SHALL INSTALL AND SUPPORT AIR PIPING AS NECESSARY TO CONNECT TO EXISTING AIR PIPING.

1
EX - 02 | EX - 03 SCALE: 1/8" = 1'-0"

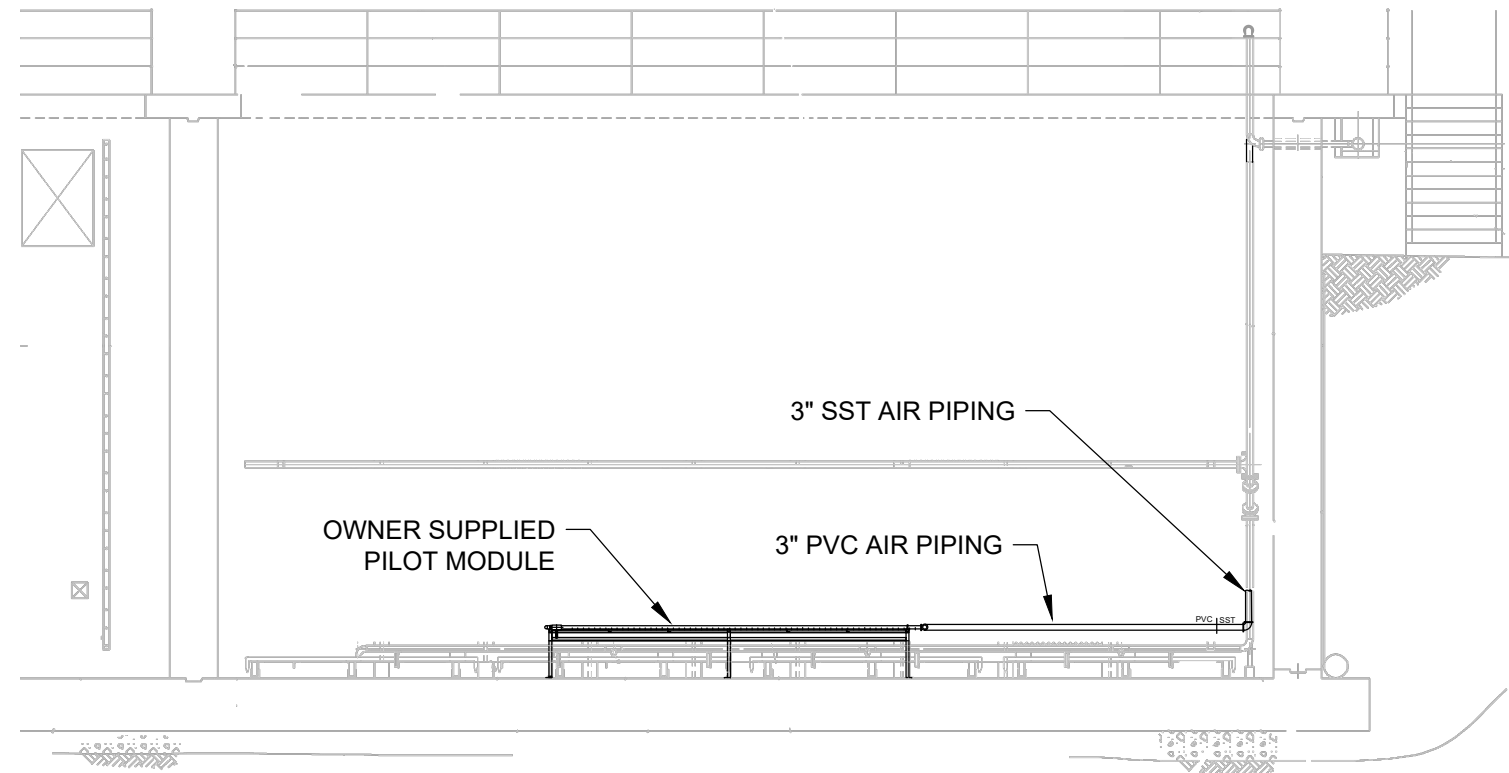

2
EX - 02 | EX - 03 SCALE: 1/8" = 1'-0"

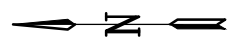

© 2023 GARVER, LLC - THIS DOCUMENT, ALONG WITH THE IDEAS AND DESIGNS CONVEYED HEREIN, SHALL BE CONSIDERED INSTRUMENTS OF PROFESSIONAL SERVICE AND ARE PROPERTY OF GARVER, LLC. ANY USE, REPRODUCTION, OR DISTRIBUTION OF THIS DOCUMENT, ALONG WITH THE IDEAS AND DESIGN CONTAINED HEREIN, IS PROHIBITED UNLESS AUTHORIZED IN WRITING BY GARVER, LLC OR EXPLICITLY ALLOWED IN THE GOVERNING PROFESSIONAL SERVICES AGREEMENT FOR THIS WORK.

THE CITY OF MIDWEST CITY MIDWEST CITY, OK MIDWEST CITY WWTP EVALUATION	REACTOR 2 SECTIONS	EXHIBIT NUMBER EX - 03	REV DATE DESCRIPTION BY
--	---------------------------	----------------------------------	----------------------------------

JOB NO.: 22W02170

DATE: 07/18/2023



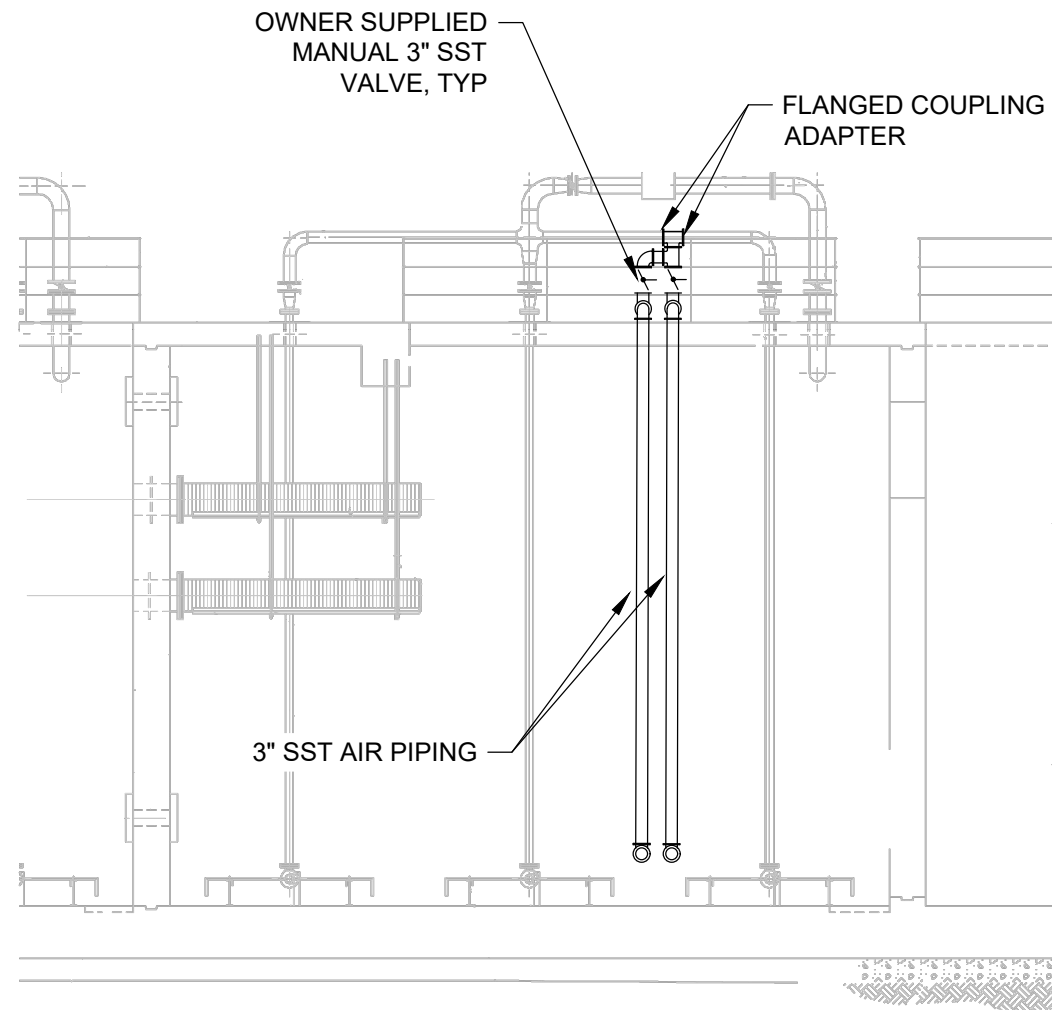

3
EX - 02 | EX - 04 SCALE: 1/8" = 1'-0"

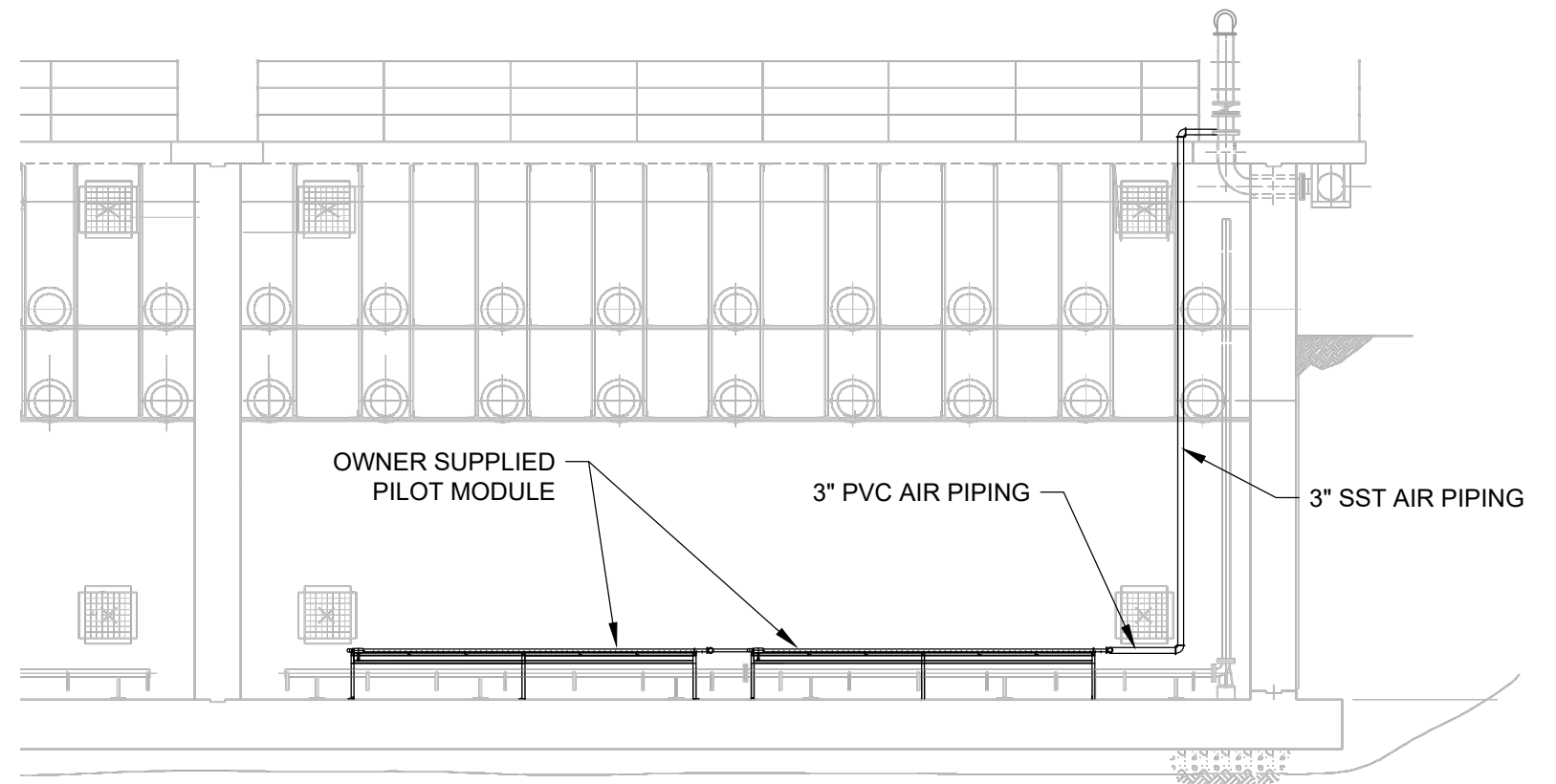

4
EX - 02 | EX - 04 SCALE: 1/8" = 1'-0"

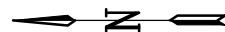

© 2023 GARVER, LLC - THIS DOCUMENT, ALONG WITH THE IDEAS AND DESIGNS CONVEYED HEREIN, SHALL BE CONSIDERED INSTRUMENTS OF PROFESSIONAL SERVICE AND ARE PROPERTY OF GARVER, LLC. ANY USE, REPRODUCTION, OR DISTRIBUTION OF THIS DOCUMENT, ALONG WITH THE IDEAS AND DESIGN CONTAINED HEREIN, IS PROHIBITED UNLESS AUTHORIZED IN WRITING BY GARVER, LLC OR EXPLICITLY ALLOWED IN THE GOVERNING PROFESSIONAL SERVICES AGREEMENT FOR THIS WORK.

THE CITY OF MIDWEST CITY
MIDWEST CITY, OK
MIDWEST CITY
WWTP EVALUATION

REACTOR 3 SECTIONS

EXHIBIT NUMBER
EX - 04

JOB NO.: 22W02170

DATE: 07/18/2023

REV	DATE	DESCRIPTION	BY



File: L:\2022\22W02170 - Midwest City WWTP Evaluation\Drawings\MWC\WTP\ED6-FO.dwg, Last Save: 7/28/2023 1:36 PM, Last saved by: NRHaynes
 Last plotted by: Natalie Haynes, Plot Style: GVR Mono 11x17.ctb, Plot Scale: 1:1, Plot Date: 7/28/2023 1:39 PM, Printer used: DWG To PDF.pc3

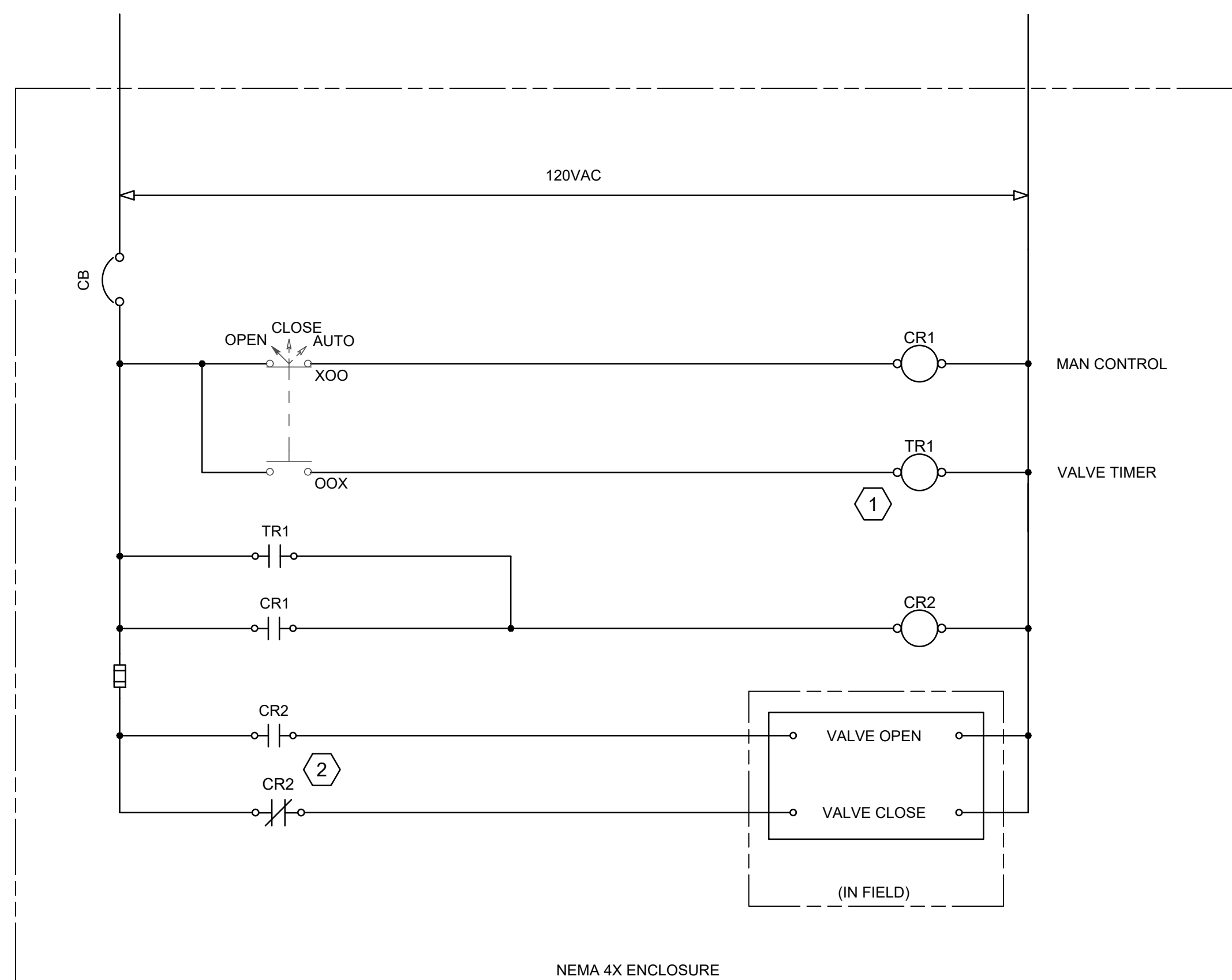

GENERAL NOTES:

1. CONTRACTOR TO COORDINATE WITH OWNER FOR TIMER RELAY CONFIGURATION.
2. NEMA 4X ENCLOSURE AND ALL ELECTRICAL, WIRING, AND RELAYS TO BE PROVIDED BY CONTRACTOR.

KEYED NOTES:

1 PHOENIX CONTACT ETD-BL-2T-I-230(-PT)

2 RELAY CONTACTS SHALL HAVE A SUFFICIENT RATING TO ACCOMMODATE THE MAXIMUM CURRENT AND VOLTAGE SPECIFICATIONS OF THE VALVE ACTUATOR. REFER TO PROVIDED ACTUATOR'S SPECIFICATION AND POWER CONSUMPTION DATA FOR DETERMINING APPROPRIATE RELAY CONTACT RATING.

© 2023 GARVER, LLC. THIS DOCUMENT, ALONG WITH THE IDEAS AND DESIGNS CONVEYED HEREIN, SHALL BE CONSIDERED INSTRUMENTS OF PROFESSIONAL SERVICE AND ARE PROPERTY OF GARVER, LLC. ANY USE, REPRODUCTION, OR DISTRIBUTION OF THIS DOCUMENT, ALONG WITH THE IDEAS AND DESIGN CONTAINED HEREIN, IS PROHIBITED UNLESS AUTHORIZED IN WRITING BY GARVER, LLC OR EXPLICITLY ALLOWED IN THE GOVERNING PROFESSIONAL SERVICES AGREEMENT FOR THIS WORK.

THE CITY OF MIDWEST CITY
 MIDWEST CITY, OK
MIDWEST CITY
WWTP EVALUATION

AERATION VALVE
CONTROL PANEL
SCHEMATIC

REV	DATE	DESCRIPTION	BY
-----	------	-------------	----

EXHIBIT NUMBER
EX - 05



JOB NO.: 22W02170

DATE: 06/28/2023

APPENDIX [C]

Entex General Contractor Support Document



July 14, 2023

To: All Bidding Contractors

Sub: Midwest City WWTP: WavTex™ Pilot WavTex System

Thank you for the opportunity to present Entex Technologies WavTex IFAS System for the Midwest City (MWC) WWTP. This scope letter is intended to provide a general overview and equipment concept for the IFAS system and is intended to assist all general bidding contractors in bid preparation for this project. Equipment details will be finalized and approved by the Engineer during the submittal process. It is the responsibility of the contractor to provide all labor, materials, equipment, and incidentals to ensure conformance with the Engineer's specifications.

Entex will provide technical support for installation and inspection, functional and performance testing, start-up supervision, and training of owner's personnel (not to exceed a total of 5 man-days). Items not specifically addressed in this quotation are excluded from scope of supply. Please reference the following pages for additional equipment details.

Sincerely,

A handwritten signature in black ink that reads "Lauren Takitch". The signature is written in a cursive, flowing style.

Lauren Takitch
Project Manager
Entex Technologies Inc
(724) 953-2425
lauren.takitch@entexinc.com
www.entexinc.com

Overview:

Unless otherwise specified herein, the IFAS system equipment, as provided by Entex, excludes anchor bolts, epoxy, glue, resin, controls, baffles, loading and unloading, storage, motor controls, site welding, site assembly, gaskets, interconnecting piping and valves, testing, penetrations or core drills, spare parts beyond those recommended, lubricants, independent inspection or testing, instrumentation, junction boxes, piping, fittings, valves, conduit, gauges, precast items, PE stamp, installation services, wiring, interconnecting cables, tanks, mixer support bridges or structures, sub-base plates, platforms, walkways, structural steel beam or channel supports, handrails, grating, motor controls or starters, hold down and installation hardware, field painting, and labor.

Entex’s WavTex system includes the design, manufacture, and supply for the following equipment further discussed in the following sections. The overall layout of equipment is depicted below. Three WavTex Modules will be installed in one of the two treatment trains. One will be installed in the first aerobic zone and two will be installed in the first aerobic zone.

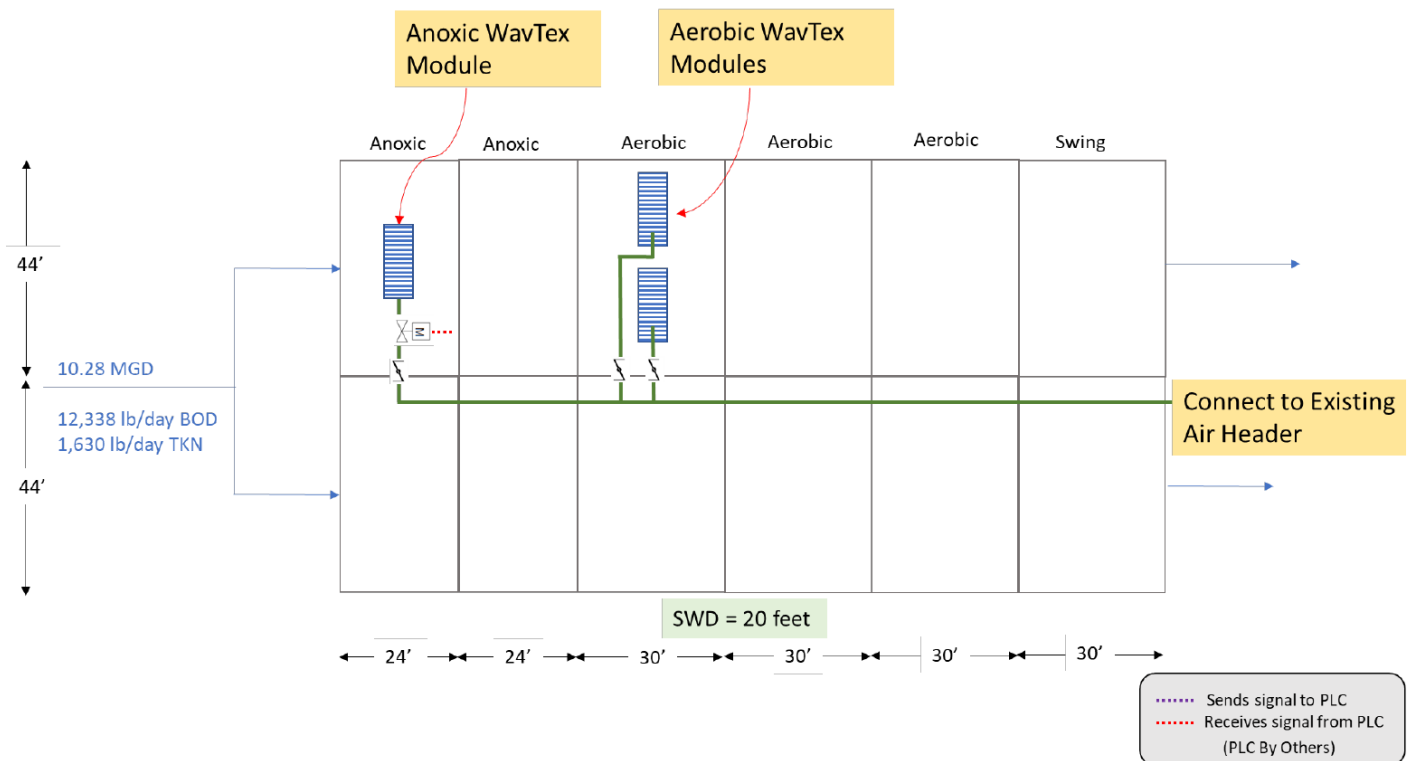

Image 1. Approximate System Layout

Item 1: WavTex Modules

1.1 WavTex Modules

Entex is supplying three (3) WavTex modules (see Entex drawings 7387-S001 to -S008 in Appendix A), one (1) electrically actuated butterfly valve for the anoxic WavTex and three (3) manual butterfly valves (one per module) for air flow balancing. All butterfly valves will be stainless steel (SS). The WavTex modules consist of a 304L stainless-steel (SS) frame with integrated coarse bubble aeration grids, 120 EnTextile media sheets, and lifting lugs attached. The EnTextile media sheets are buoyant when placed in water but will arrive laying on the SS frame upon arrival, as pictured below. The WavTex aeration scope break is a three-inch diameter, 150 lb ANSI PVC flange (one per module) which will ship loose during transit. The butterfly valves will also ship loose. The contractor is responsible for all connections between the PVC flanges, the butterfly valves, and the main process air header. More details about the installation and scope break can be found below.

Since the EnTextile media sheets do not stand up until they are placed in the water, the modules will be approximately 15 feet long, 6 feet wide and 5 feet tall upon arrival (18 feet tall when placed in the water). The pictures below show what the WavTex modules will look like upon arrival. The MWC WavTex modules weigh approximately 1,000 lbs each.



Image 2. Example Shrink-Wrapped WavTex Upon Arrival



Image 3. Example WavTex Unit (front view)
(Note - MWC flanged aeration scope break is different than shown)



Image 4. Example WavTex Unit (side view)
(Note - MWC flanged aeration scope break is different than shown)

The WavTex modules will be lowered into position with a crane, hoist or other device such that the four feet sit on the tank floor. At this point the feet will be bolted to the floor and the aeration piping will be connected to the modules (ref. bolt hole detail on drawing -S003).

1.2 WavTex Aeration

Each WavTex unit comes with a Schedule 80 PVC integral coarse bubble aeration grid, mounted beneath the WavTex frame (ref. WavTex Drawings -S005 and -S006). As delivered, each aeration grid terminates with an upward facing 3" diameter PVC pipe, approximately 3 feet from the tank floor. The contractor will then connect this pipe stub to the Entex-supplied PVC flange onsite. The contractor will supply and install one 3" SS aeration drop pipe per module. The contractor-supplied SS drop pipe will terminate with a SS flange to mate with the PVC flange (Entex scope break). Contractor is responsible for connection to butterfly valves and main process aeration header as well as drop pipe supports, anchors, and fasteners.

Item 2: Valves

Entex is supplying one (1) wafer style 3-inch electrically actuated butterfly valve for occasional air scour of the EnTextile media for the anoxic WavTex module and three (3) wafer style 3-inch SS butterfly valves for flow balancing (one per WavTex module). The contractor is responsible for making the connections between the WavTex modules, the butterfly valves, and the main process air header.

Item 3: Delivery

The contractor shall be responsible for unloading and storage onsite or at a mutually accepted storage area per contract with the Owner. A forklift and/or crane must be used to unload the units. A thorough inventory of received goods shall be taken in order to make sure all ordered materials have been delivered. If equipment is missing, please annotate on truck drivers manifest, and contact Entex within 24 hours. An inspection of goods must be performed for physical and hidden damage to materials. Physical damage consists of broken welds, torn fabric media, damaged steel, and or broken ties. Contractor is responsible for field verifying dimensions and interferences of the existing tank for fit.

5.1 WavTex Units

- Dry Weight: 1,000 pounds
- Frame Material: 304L Stainless Steel
- Length: 15 feet
- Width: 6
- Height: 4 feet (out of water), 18 feet (in water)

All WavTex units will come nearly fully assembled aside from the PVC flange which will ship loose. The butterfly valves will also ship loose. It is the contractor's responsibility to connect the WavTex integral air grids (terminating in a 3" PVC pipe) to the Entex-supplied 3" diameter flanges, connecting the PVC flanges to the contractor-supplied SS drop pipes, and supplying all piping and fitting necessary to connect the SS drop pipes to the butterfly valves and the butterfly valves to the main process header. The integrated coarse bubble aeration grids will be pre-mounted underneath the frame. Note that the self-buoyant EnTextile media sheets will not stand up until they are placed in the water. Upon arrival, the EnTextile media sheets will be laying on top of the frame and shrink wrapped to the frame as pictured in Image 1 above.

Item 4: WavTex Storage

The Contractor shall store equipment upon delivery. If the EnTextile media is expected to be exposed to sunlight for an extended period of time, measures must be taken to reduce the impact of solar degradation of the EnTextile fabric. All units to be stored in the open for more than two months shall use a light-colored cover. Ideally these covers should be double sided, such as a white on black. The white outward facing side should reflect light. Clear covers are prohibited. Black will absorb heat and if the cover comes in direct contact with the fabric media, this heat can be quickly transferred. Covers should not be wrapped tightly around the frames. The ends of the cover should be securely anchored on all sides with at least a 12-inch air gap at the bottom. These covers must provide shade while allowing airflow to prevent buildup of heat. Units should be stored upright to prevent compression of EnTextile fabric. During storage, the units should be checked regularly to identify minor repairs. Covers can become loose over time due to wind or rain and must be re-secured.



Image 5. Example WavTex Cover

Item 5: Installation

5.1 WavTex Installation

Contractor will install the WavTex units onsite by following the instructions listed below:

- Offload WavTex units and remove the shrink wrap

- Lower the WavTex modules into place in the tank using their lifting lugs
 - Note that each module weighs approximately 1,000 lbs dry. The actual weight can be found on the delivery driver's manifest. It is the contractor's responsibility to check and verify this weight upon delivery.
- Bolt the WavTex modules to the tank floor
 - Each WavTex module has six feet and each foot will require one of its three available bolt holes to be bolted to the tank floor (one ½" 304 SS Hilti-type lag bolt per foot, bolts by contractor).
 - In order to bolt the modules to the tank floor, the tank will be dewatered prior to installation.
- Attach the WavTex module aeration piping to the air header
 - Entex's scope break terminates with a three-inch diameter PVC flange (one per module) which will ship loose. The contractor will connect this PVC flange to the WavTex three-inch diameter air grid piping (PVC cement by contractor). The contractor can field cut the PVC pipe if required.
 - The contractor is responsible for all SS piping and fittings required to connect the WavTex modules to the air header. A SS drop pipe (by contractor, one per module) will be used to transition from Entex's PVC air grid to SS.
 - The contractor is responsible for installing the four (4) 3" SS butterfly valves (3 manual, 1 automatic). Flange bolts and interconnecting piping by contractor.
- Upon connecting all of the aeration piping, the contractor will attach the downcomers to the tank walls with brackets (brackets supplied by contractor).
- Upon connecting the modules to the air header and securing the modules in the tank, the forward flow to the plant will resume.
- Air flow will be balanced to the three WavTex modules visually. The electrically actuated butterfly valve will be programmed for a time based scour of the anoxic WavTex module (controls by others). Entex will be onsite to supervise this startup.

Experience has shown that installation of the WavTex units can be accomplished in one day with a four-man crew and a lift operator once the WavTex modules are present onsite. The time limiting factor during installation is the time required to bolt each WavTex foot to the tank floor. Typical installation information is no guarantee of time and equipment. Each installation varies and this information is provided as general background.

Item 6: Scope Breaks

6.1 WavTex Scope Breaks

Entex's scope break ends with one (1) three-inch Schedule 80 PVC flange terminating approximately three feet from the tank floor. The contractor will supply a SS aeration drop pipe terminating with a SS flange for connection to the WavTex air grids. Entex will supply one (1) SS three-inch manual butterfly valve per module and one (1) SS three-inch electrically actuated

butterfly valve for the single anoxic module. The contractor will supply all additional pieces and hardware required to connect the WavTex modules to the butterfly valves and to connect the WavTex modules to the main process air header including drop pipe supports, bolts, brackets, joint glue, and anchors.

6.2 Scope Break Diagrams

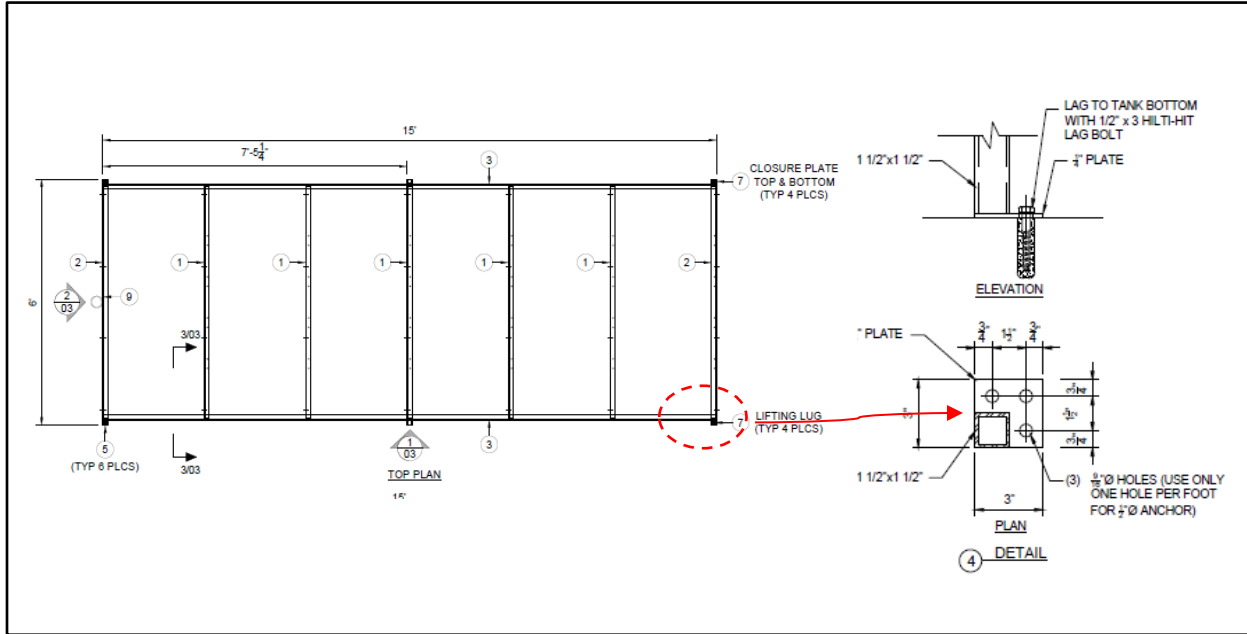

Image 6. Feet of WavTex Modules to be Bolted on Tank Floor (WavTex Scope Break 1 of 2)

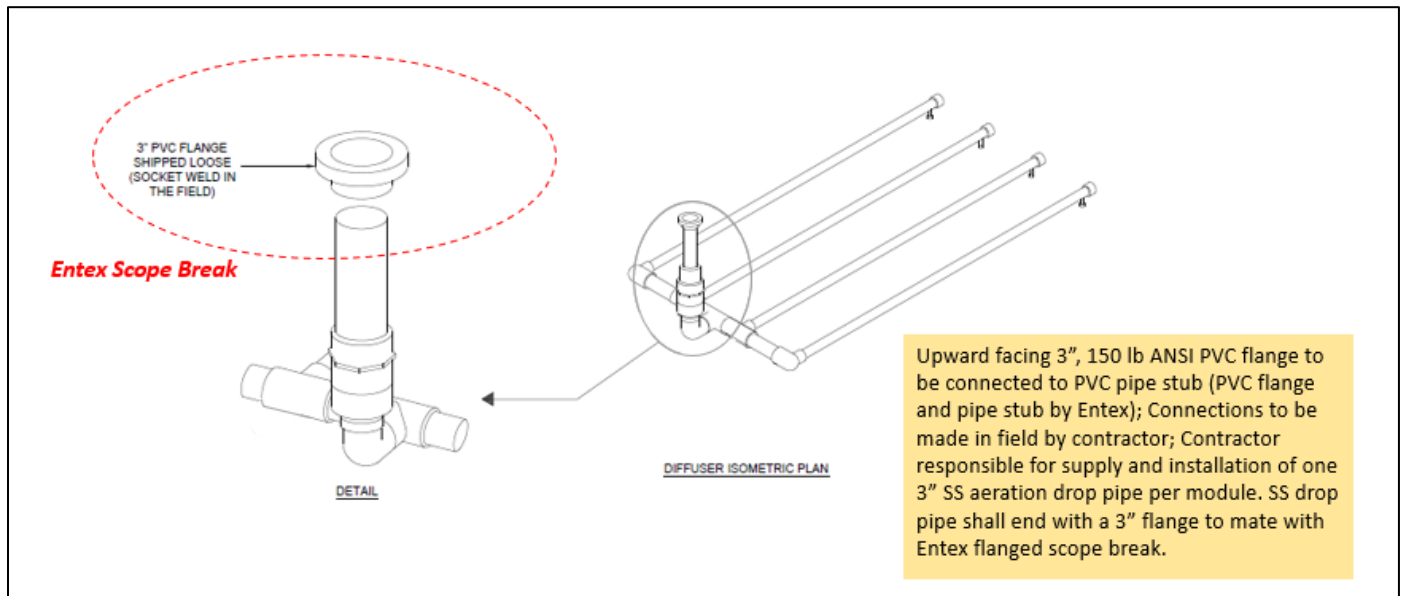

Image 7. WavTex Aeration Grid Terminates with 3\" ANSI PVC flange (WavTex Scope Break 2 of 2)

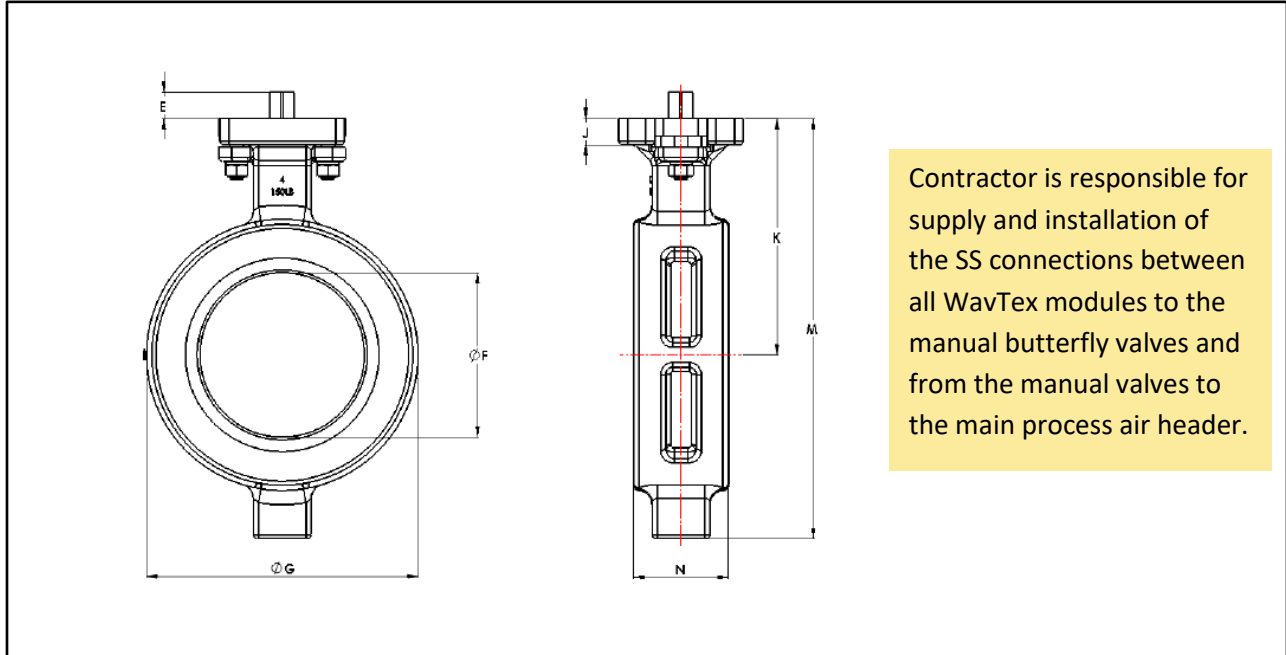

Image 8. 3" SS Wafer Body Manual Butterfly Valves (One per WavTex Module)

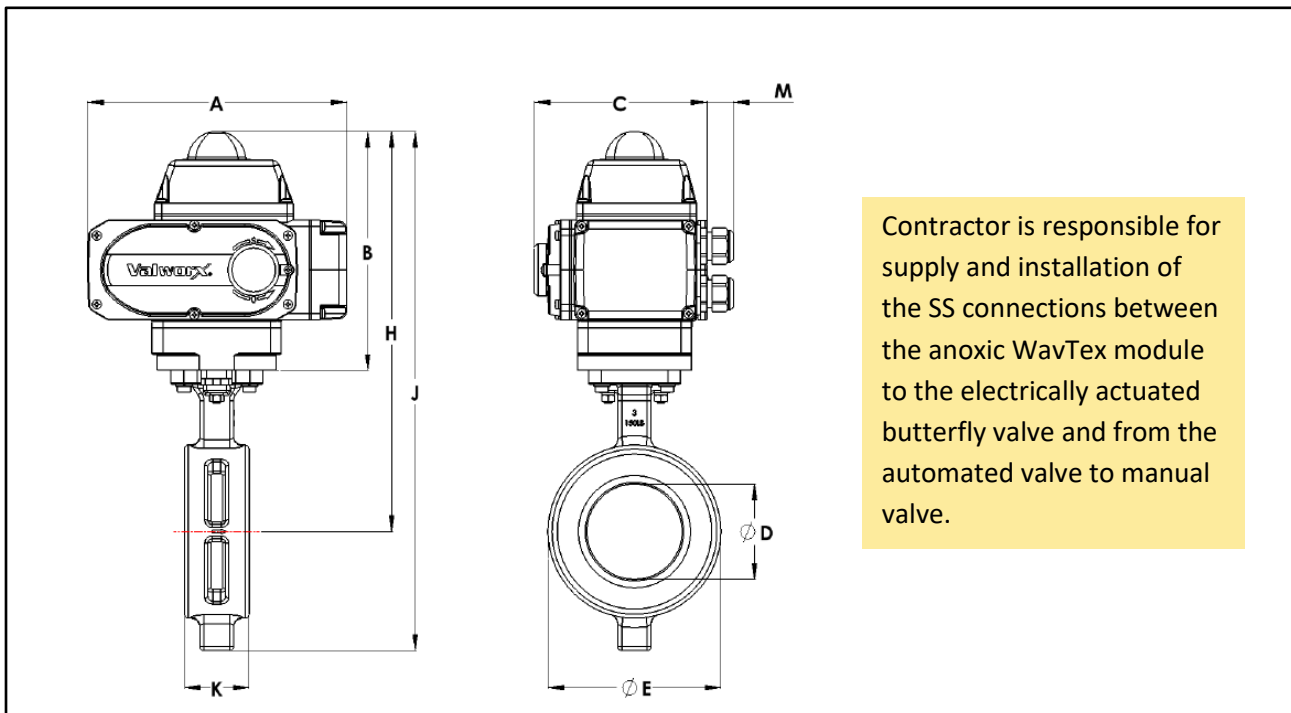
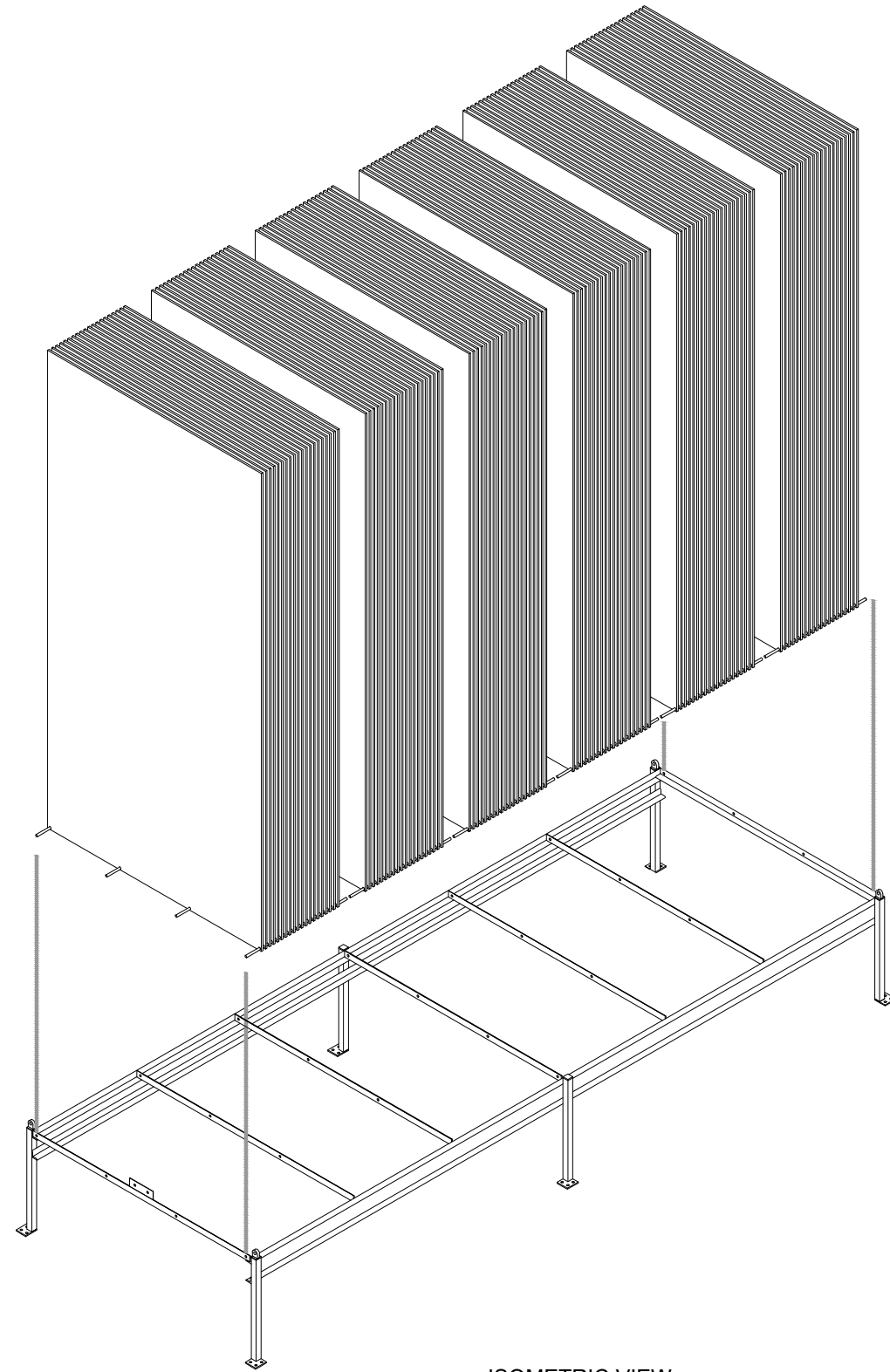

Image 9. 3" SS 120 VAC Wafer Body Electrically Actuated Butterfly Valves for Anoxic WavTex

Appendix

A) WavTex Drawings

04/14/2023 10:31am - Admin - C:\Users\Admin\AppData\Local\Temp\AcadP\dwg\12360\7387 - Wavtex_04-14-23_Submittal.dwg



ISOMETRIC VIEW

Weight = 1000 lbs.

Notes

This drawing contains confidential data and information that is the property of Entex Technologies Inc. It is not to be copied or disclosed to third parties without prior written permission from Entex Technologies Inc.

Rev	Date	Description	By	App'd

TOLERANCE UNLESS NOTED:
 ALL DIMENSIONS IN INCHES
 DIMENSIONS IN [] = METRIC
 BREAK ALL SHARP EDGES
 CONNECTION POINTS = ± 1/4"
 ANGLES = ± 1°
 NON-FUNCTIONAL DIM'S = ± 1"

DRAWN ACS DATE 03-13-20
 CHECKED JD DATE 03-13-20
 APPROVED JD DATE 03-13-20
 NEXT ASS'Y WEIGHT



Engineering Clean Water Solutions

Entex Technologies Inc.
 1340 Environ Way
 Chapel Hill, NC 27517
 (919) 913-4798
 www.EntexInc.com

Title		WAVTEX FRAME Midwest City WWTP WavTex Pilot	
Scale	NONE	Dwg. No.	7387-S001
SUBMITTAL		Rev.	0

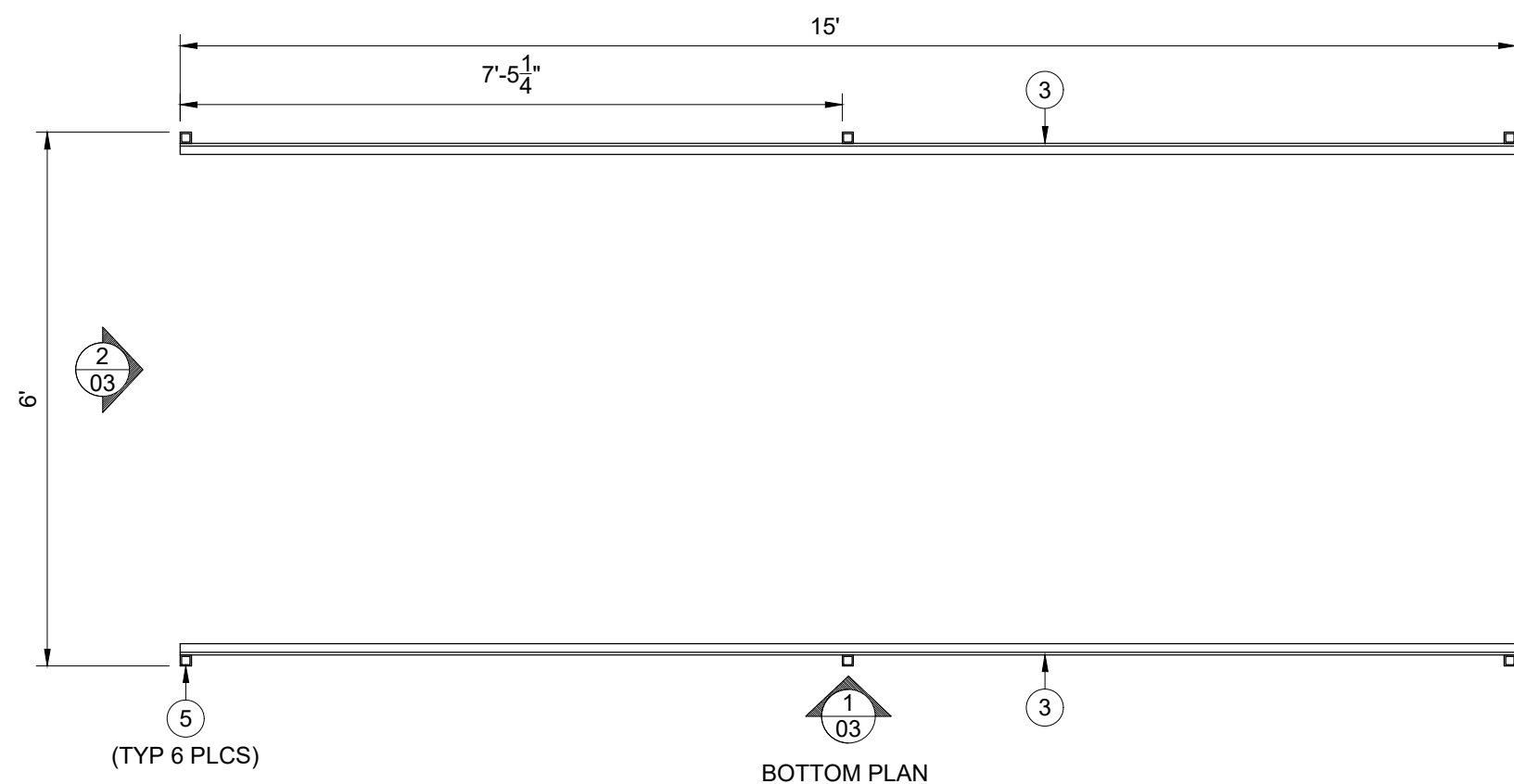
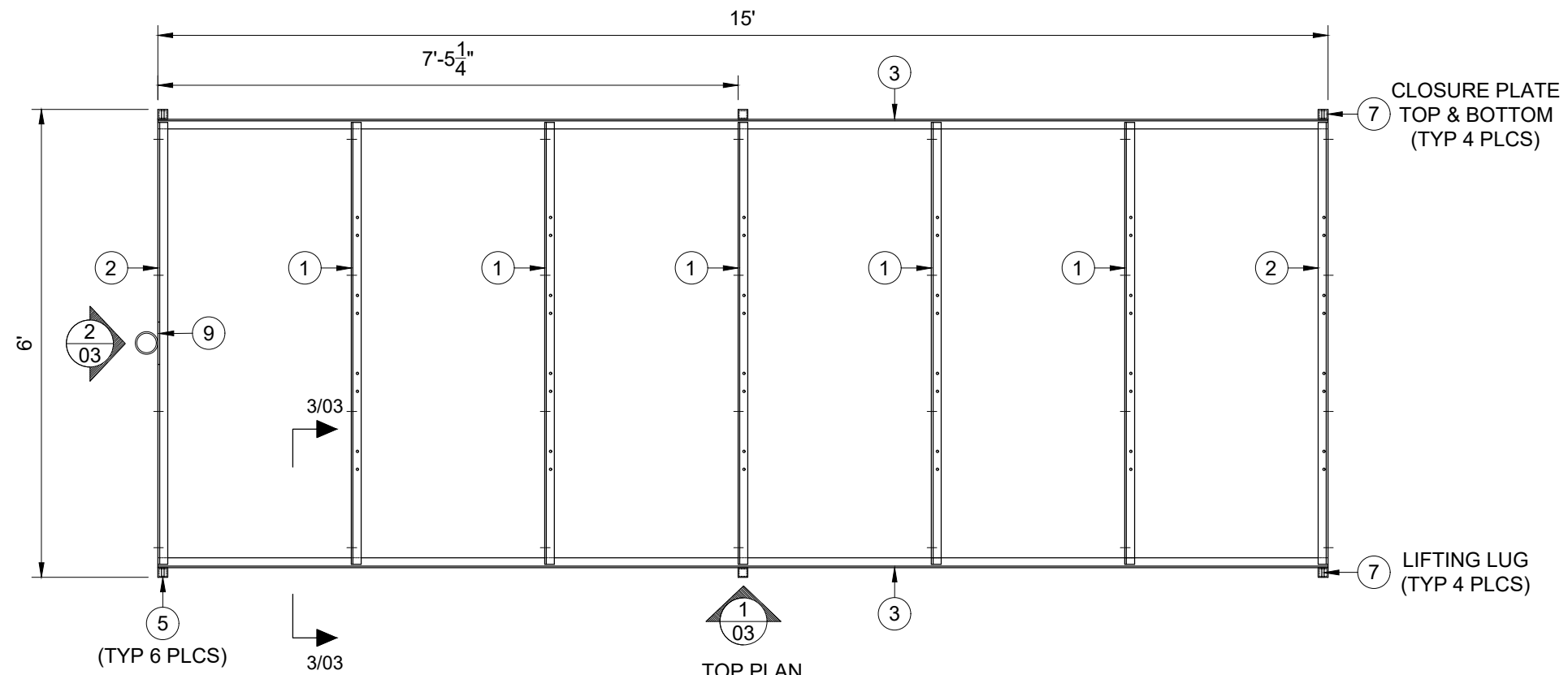

04/14/2023 10:31am - Admin - C:\Users\Admin\AppData\Local\Temp\AcPublish-12360\7387-Wavtex_04-14-23_Submittal.dwg

Notes

This drawing contains confidential data and information that is the property of Entex Technologies Inc. It is not to be copied or disclosed to third parties without prior written permission from Entex Technologies Inc.

Rev	Date	Description	By	App'd

TOLERANCE UNLESS NOTED:
 ALL DIMENSIONS IN INCHES
 DIMENSIONS IN [] = METRIC
 BREAK ALL SHARP EDGES
 CONNECTION POINTS = ± 1/4"
 ANGLES = ± 1°
 NON-FUNCTIONAL DIM'S = ± 1"

DRAWN ACS DATE 03-13-20
 CHECKED JD DATE 03-13-20
 APPROVED JD DATE 03-13-20
 NEXT ASS'Y WEIGHT

Entex Technologies Inc.
 1340 Environ Way
 Chapel Hill, NC 27517
 (919) 913-4798
 www.EntexInc.com

Title		WAVTEX FRAME Midwest City WWTP WavTex Pilot	
Scale	Dwg. No.	Rev.	
1/2"=1'-0"	7387-S002	0	
SUBMITTAL			

04/14/2023 10:31am - Admin - C:\Users\Admin\AppData\Local\Temp\AcPublish-12360\7387-Wavtex_04-14-23_Submittal.dwg

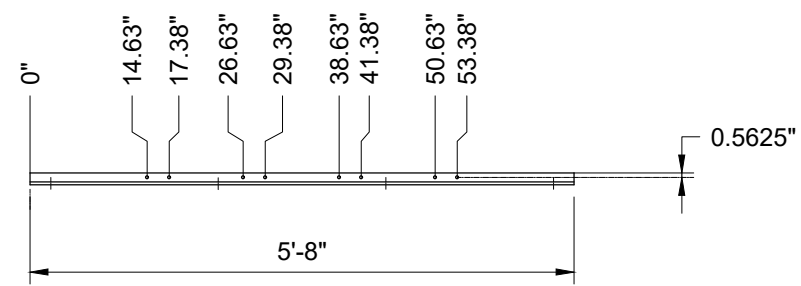

ITEM 1 TOP VIEW

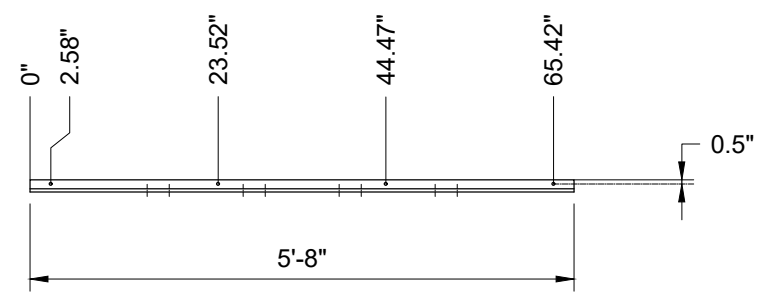

ITEM 1 SIDE VIEW

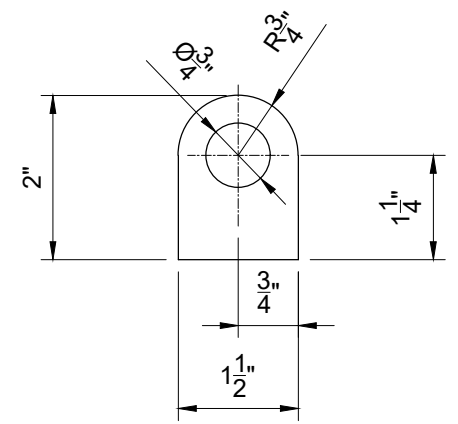

ITEM 6 DETAIL

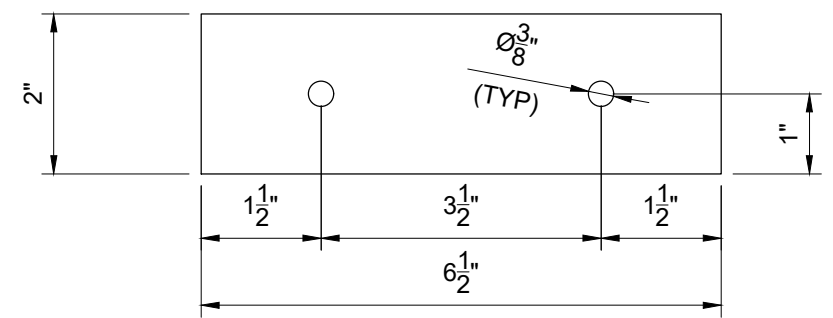

ITEM 9 DETAIL

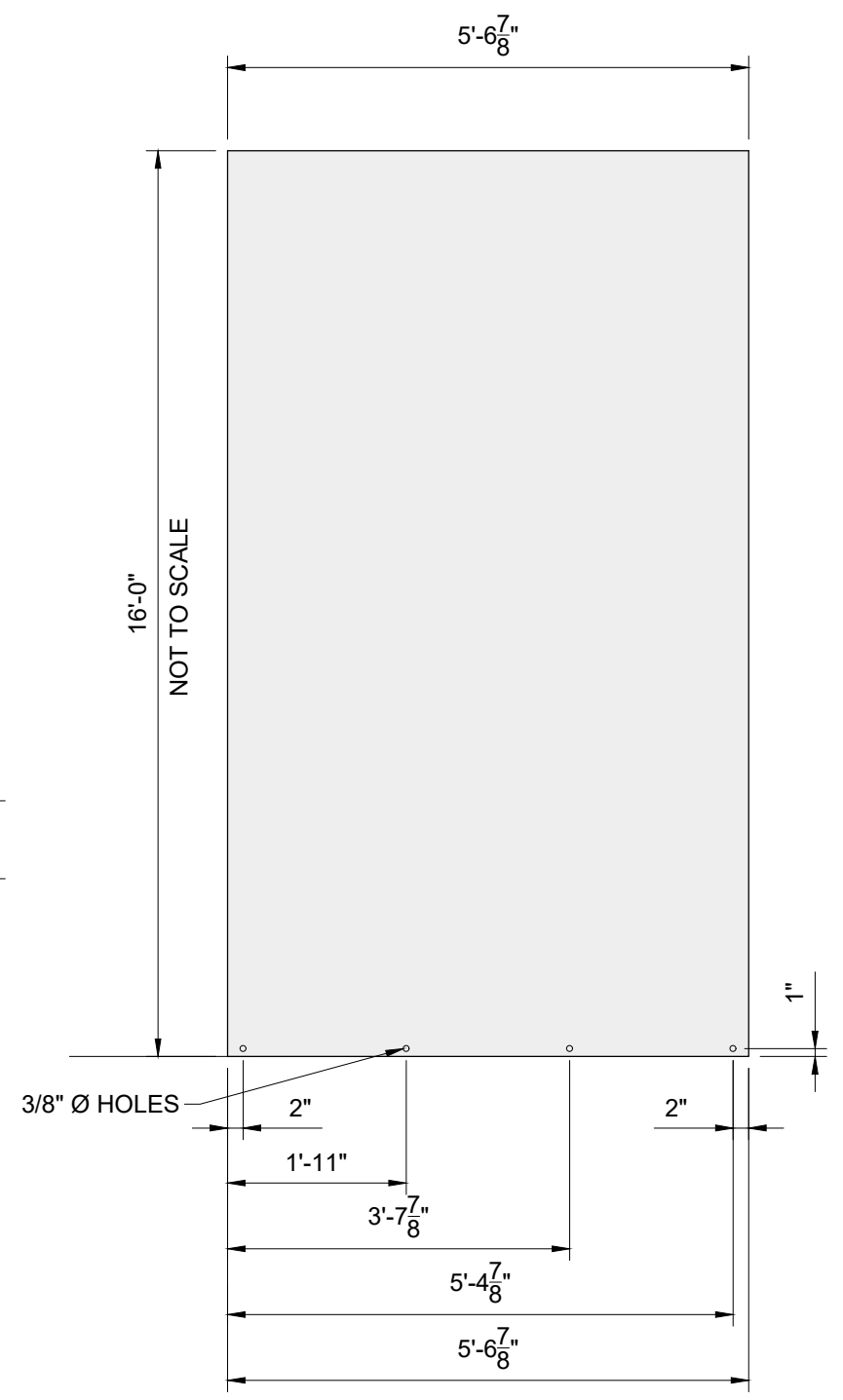

MEDIA SHEET

Notes

This drawing contains confidential data and information that is the property of Entex Technologies Inc. It is not to be copied or disclosed to third parties without prior written permission from Entex Technologies Inc.

Rev	Date	Description	By	App'd

TOLERANCE UNLESS NOTED:
 ALL DIMENSIONS IN INCHES
 DIMENSIONS IN [] = METRIC
 BREAK ALL SHARP EDGES
 CONNECTION POINTS = ± 1/4"
 ANGLES = ± 1°
 NON-FUNCTIONAL DIM'S = ± 1"

DRAWN ACS DATE 03-13-20
 CHECKED JD DATE 03-13-20
 APPROVED JD DATE 03-13-20
 NEXT ASS'Y WEIGHT



Engineering Clean Water Solutions

Entex Technologies Inc.
 1340 Environ Way
 Chapel Hill, NC 27517
 (919) 913-4798
 www.EntexInc.com

Title		WAVTEX FRAME Midwest City WWTP WavTex Pilot	
Scale	NONE	Dwg. No.	7387-S004
SUBMITTAL		Rev.	0

04/14/2023 10:31am - Admin - C:\Users\Admin\AppData\Local\Temp\AcP\dwg\12360\7387 Wavtex_04-14-23_Submittal.dwg

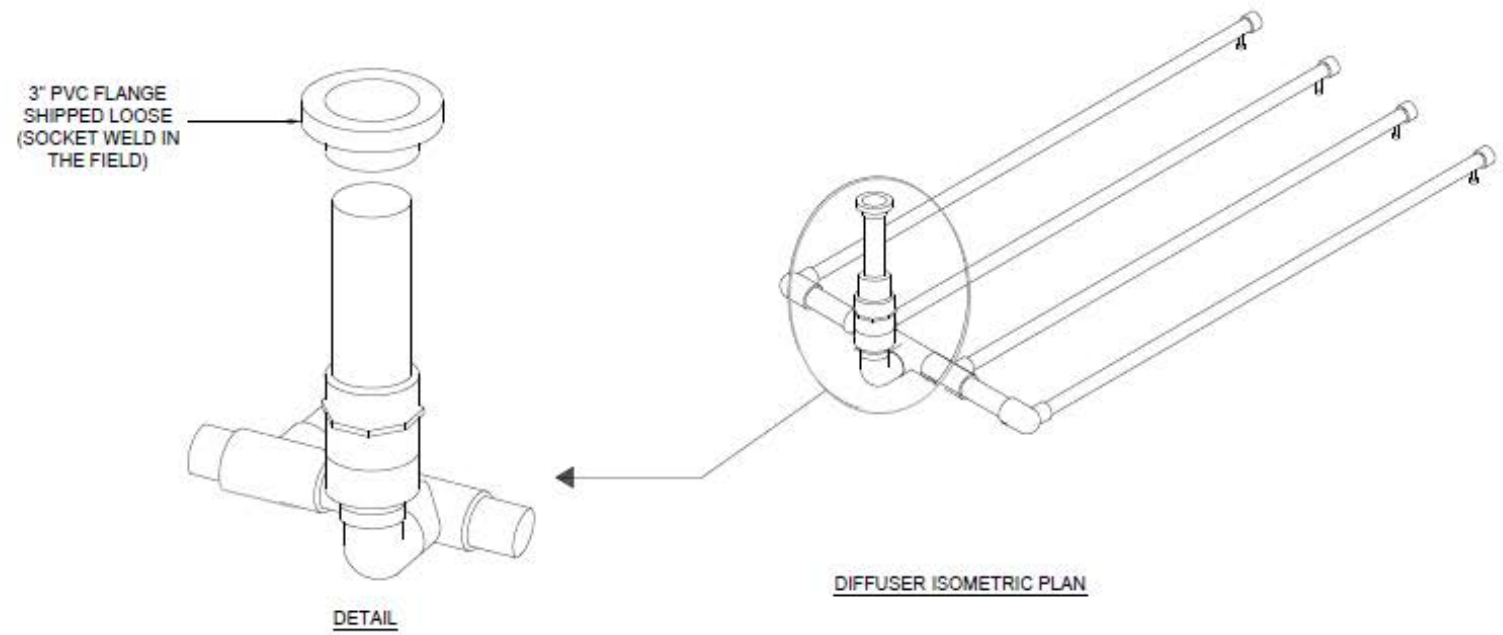

Notes

This drawing contains confidential data and information that is the property of Entex Technologies Inc. It is not to be copied or disclosed to third parties without prior written permission from Entex Technologies Inc.

Rev	Date	Description	By	App'd

TOLERANCE UNLESS NOTED:
 ALL DIMENSIONS IN INCHES
 DIMENSIONS IN [] = METRIC
 BREAK ALL SHARP EDGES
 CONNECTION POINTS = ± 1/4"
 ANGLES = ± 1°
 NON-FUNCTIONAL DIM'S = ± 1"

DRAWN ACS DATE 03-13-20
 CHECKED JD DATE 03-13-20
 APPROVED JD DATE 03-13-20
 NEXT ASS'Y WEIGHT



Engineering Clean Water Solutions

Entex Technologies Inc.
 1340 Environ Way
 Chapel Hill, NC 27517
 (919) 913-4798
 www.EntexInc.com

Title		WAVTEX FRAME Midwest City WWTP WavTex Pilot	
Scale	Dwg. No.	Rev.	
NONE	7387-S005	0	
SUBMITTAL			

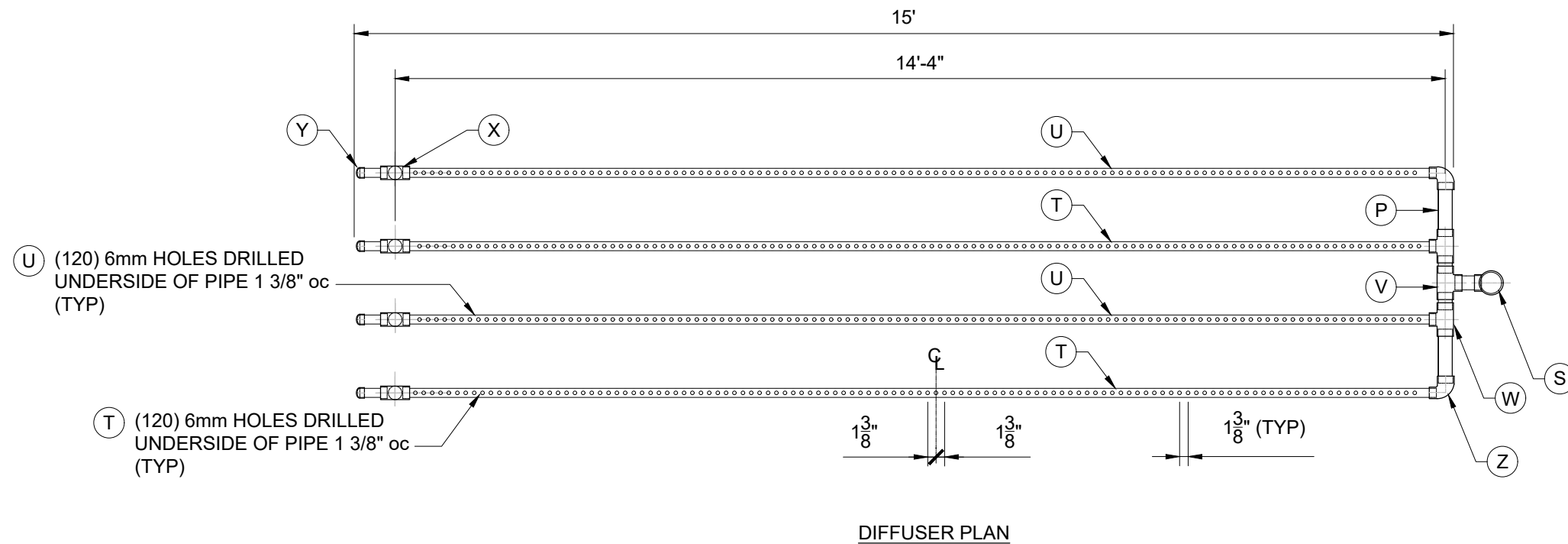
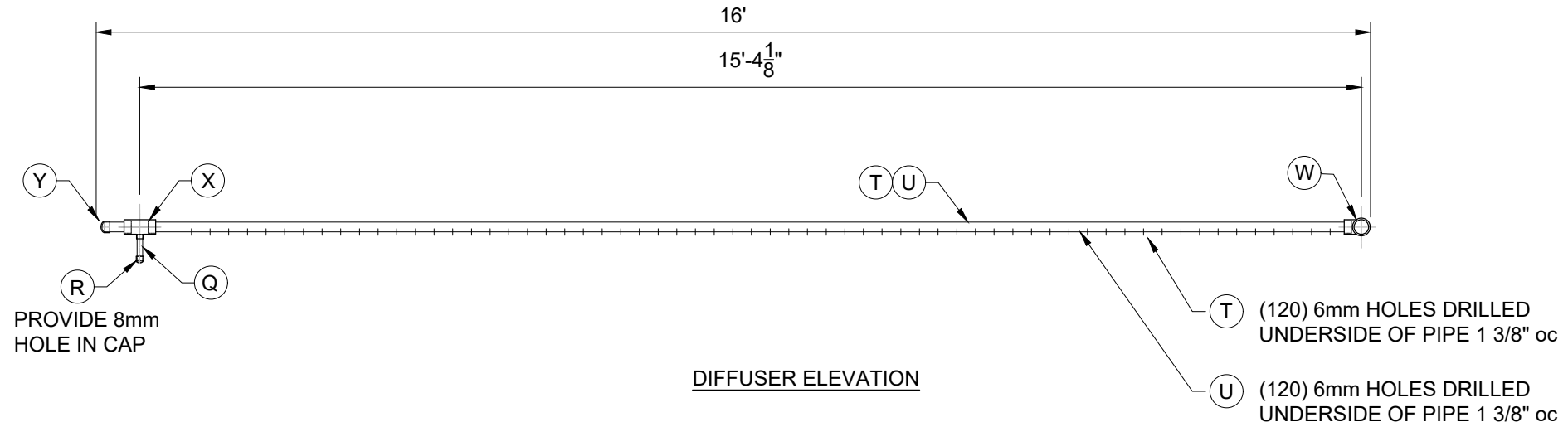

04/14/2023 10:31am - Admin - C:\Users\Admin\AppData\Local\Temp\AcPublish-17360\7387-Wavtex_04-14-23_Submittal.dwg

Notes

This drawing contains confidential data and information that is the property of Entex Technologies Inc. It is not to be copied or disclosed to third parties without prior written permission from Entex Technologies Inc.

Rev	Date	Description	By	App'd

TOLERANCE UNLESS NOTED:
 ALL DIMENSIONS IN INCHES
 DIMENSIONS IN [] = METRIC
 BREAK ALL SHARP EDGES
 CONNECTION POINTS = ± 1/4"
 ANGLES = ± 1°
 NON-FUNCTIONAL DIM'S = ± 1"

DRAWN ACS DATE 03-13-20
 CHECKED JD DATE 03-13-20
 APPROVED JD DATE 03-13-20
 NEXT ASS'Y WEIGHT



Engineering Clean Water Solutions

Entex Technologies Inc.
 1340 Environ Way
 Chapel Hill, NC 27517
 (919) 913-4798
 www.EntexInc.com

Title		WAVTEX FRAME Midwest City WWTP WavTex Pilot	
Scale	NONE	Dwg. No.	7387-S006
SUBMITTAL		Rev.	0

C:\Users\Admin\AppData\Local\Temp\AcPublish-12360\7387-Wavtex_04-14-23_Submittal.dwg

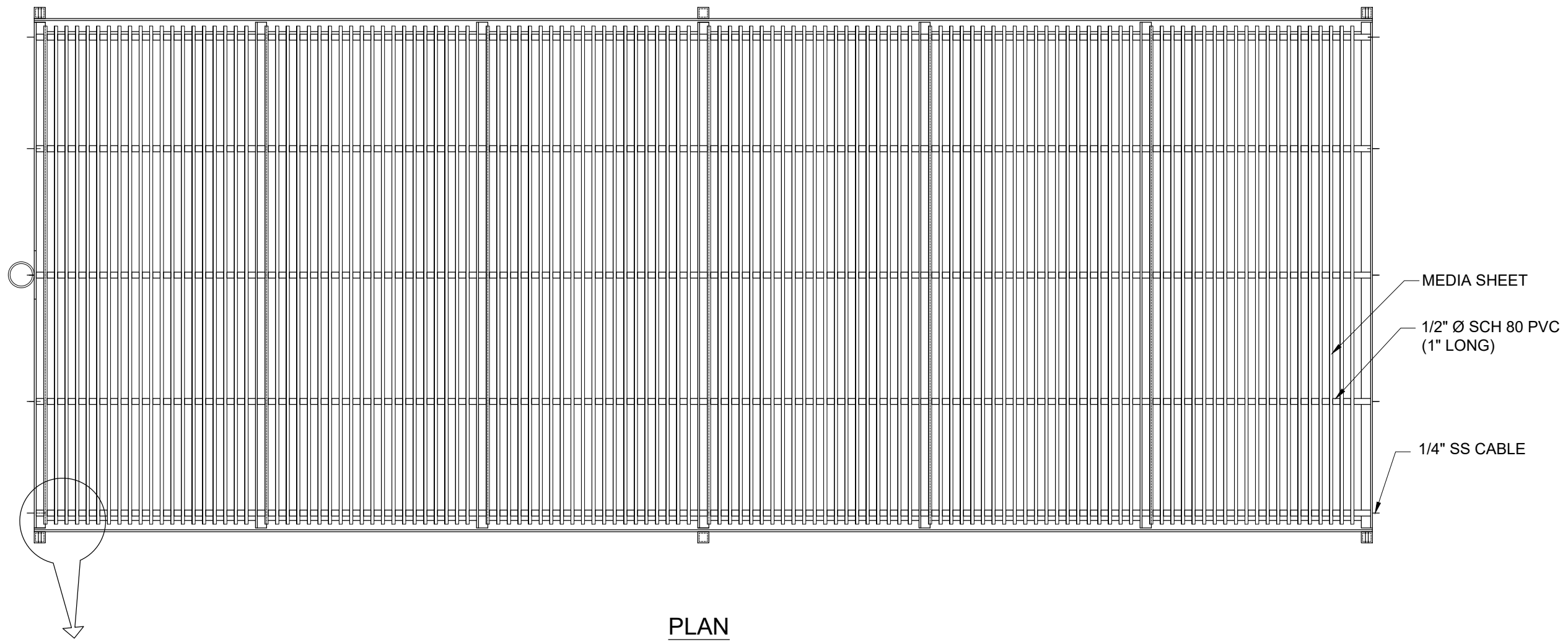

PLAN

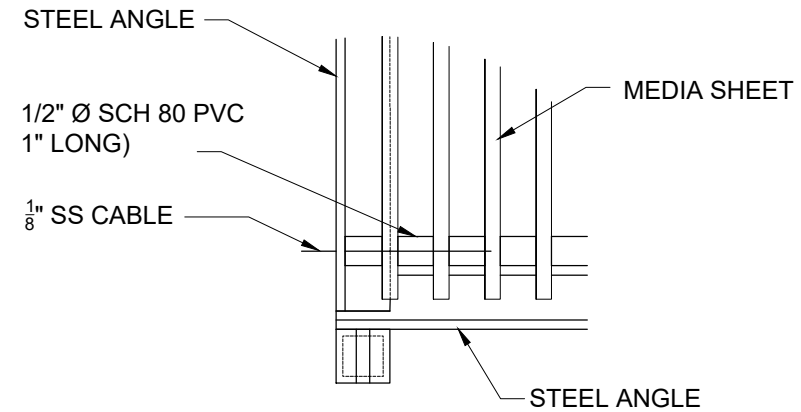

ENLARGED DETAIL

Notes

This drawing contains confidential data and information that is the property of Entex Technologies Inc. It is not to be copied or disclosed to third parties without prior written permission from Entex Technologies Inc.

Rev	Date	Description	By	App'd

TOLERANCE UNLESS NOTED:
 ALL DIMENSIONS IN INCHES
 DIMENSIONS IN [] = METRIC
 BREAK ALL SHARP EDGES
 CONNECTION POINTS = ± 1/4"
 ANGLES = ± 1°
 NON-FUNCTIONAL DIM'S = ± 1"

DRAWN	ACS	DATE	03-13-20
CHECKED	JD	DATE	03-13-20
APPROVED	JD	DATE	03-13-20
NEXT ASS'Y	WEIGHT		



Engineering Clean Water Solutions

Entex Technologies Inc.
 1340 Environ Way
 Chapel Hill, NC 27517
 (919) 913-4798
 www.EntexInc.com

Title		WAVTEX FRAME Midwest City WWTP WavTex Pilot	
Scale	Dwg. No.	Rev.	
3/4"=1'-0"	7387-S007	0	
SUBMITTAL			

DIMENSION	ft	
A	15.0	
B	6.00	
C	18.0	
D	2.00	
E	16.0	
F	NUMBER OF SHEETS = 120	
G	1.0	

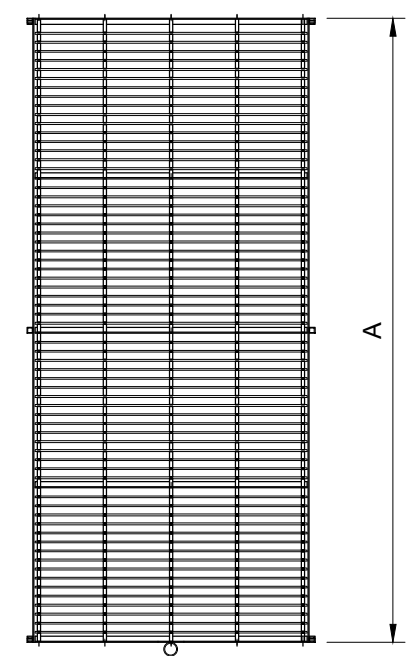

TOP

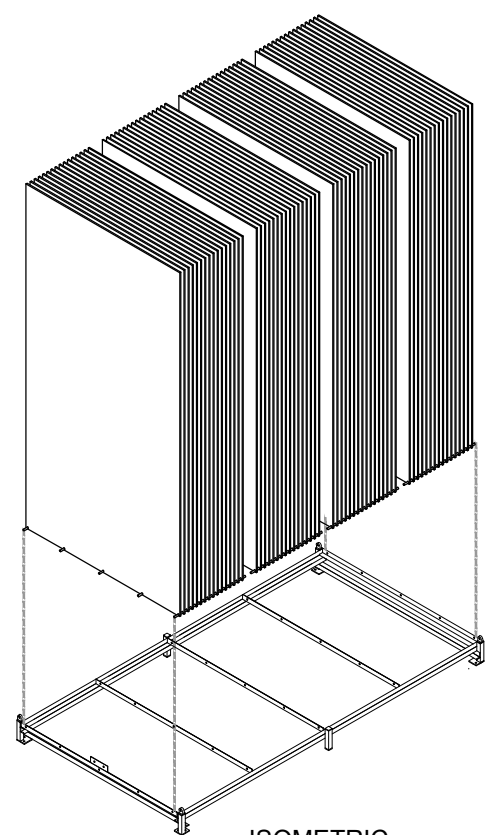

ISOMETRIC

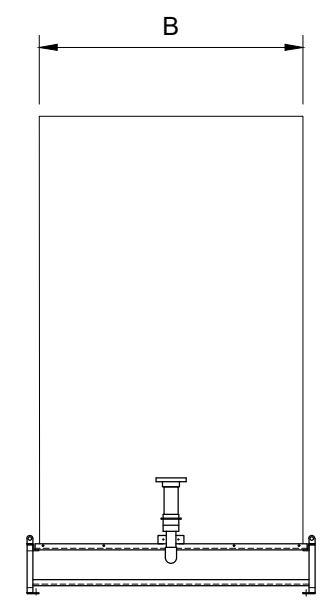

FRONT

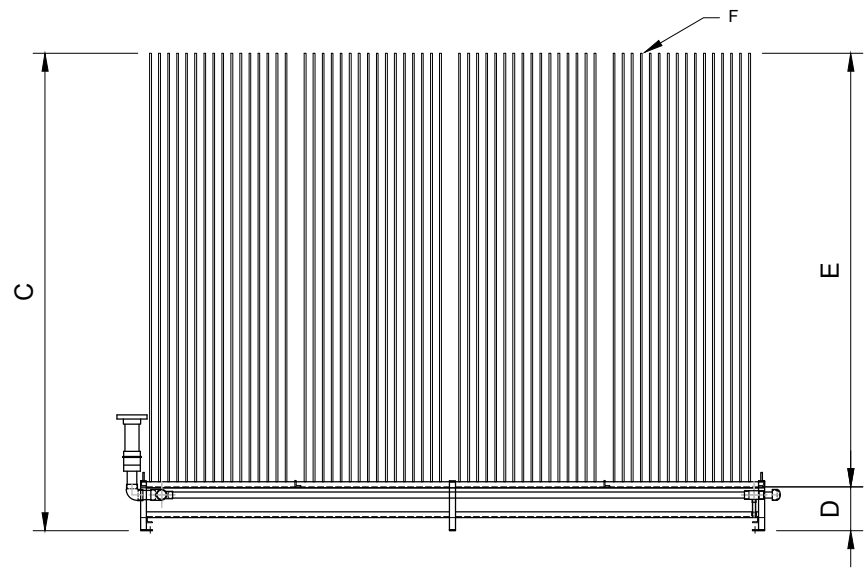

SIDE

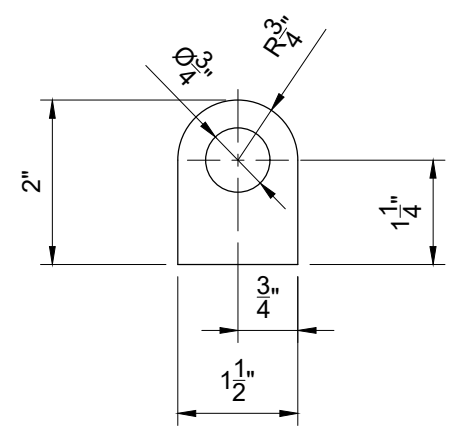
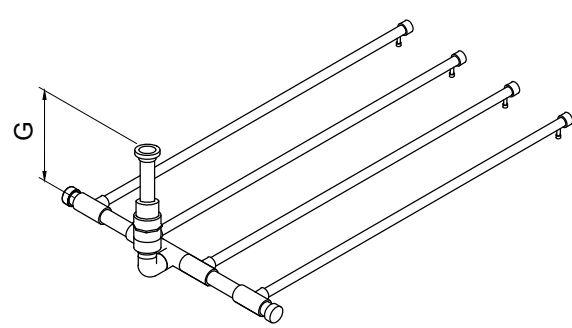

LIFTING LUG DETAIL

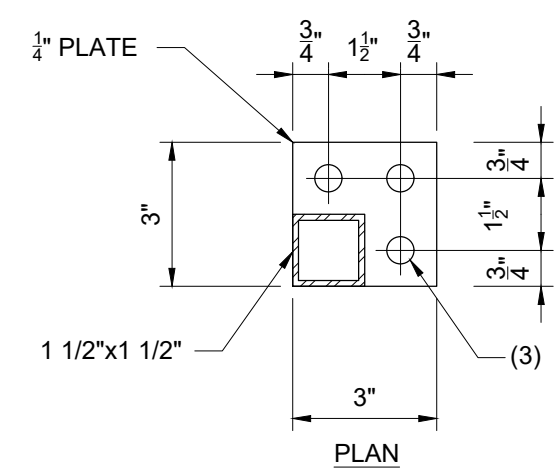

PLAN

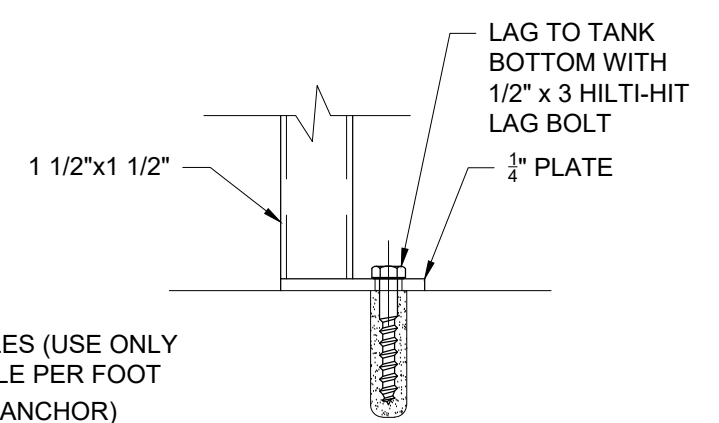

ELEVATION

BASE PLATE DETAIL

07/11/2023 3:44pm - Admin - H:\654 - Entex\654-149 Typical Wavtex Typical Wavtex 7-11-23 Submittal.dwg

Notes
TYPICAL WAVTEX DRAWING SET.
DIMENSIONS MAY NOT TO BE SCALE.

This drawing contains confidential data and information that is the property of Entex Technologies Inc. It is not to be copied or disclosed to third parties without prior written permission from Entex Technologies Inc.

Rev	Date	Description	By	App'd

TOLERANCE UNLESS NOTED:
ALL DIMENSIONS IN INCHES
DIMENSIONS IN [] = METRIC
BREAK ALL SHARP EDGES
CONNECTION POINTS = ± 1/4"
ANGLES = ± 1°
NON-FUNCTIONAL DIM'S = ± 1"

DRAWN ACS DATE 07-20-22
CHECKED LT DATE 07-20-22
APPROVED LT DATE 07-20-22
NEXT ASS'Y WEIGHT

Engineering Clean Water Solutions

Entex Technologies Inc.
1340 Environ Way
Chapel Hill, NC 27517
(919) 913-4798
www.EntexInc.com

Title WAVTEX FRAME Midwest City WWTP WavTex Pilot		Scale NONE	Dwg. No. 7387-S008	Rev. 0
--	--	---------------	-----------------------	-----------

B) Cut Sheets

WavTex™ by ENTEX Technologies

Moving Flex Media

Engineering
Clean Water
Solutions



WavTex

is a moving woven media system using Entex's patent pending EnTextile™ media in Integrated Fixed-film Activated Sludge (IFAS) and Submerged Fixed-Film (SFF) systems.

Independently moving EnTextile media sheets continually wave in the aeration basin in a random motion, ensuring excellent oxygen and substrate transfer.

WavTex is a cost-effective solution for existing activated sludge plants that need more advanced treatment. Because little or no additional tankage is required, WavTex is ideal for plants with limited room for expansion.

It is also an excellent choice for space efficient, high performance new plant designs.

EnTextile Media

EnTextile media provides an exceptionally high effective biological surface area, and the narrow thickness of the media provides excellent transfer of waste and oxygen to the thin biological film, providing high rate treatment.

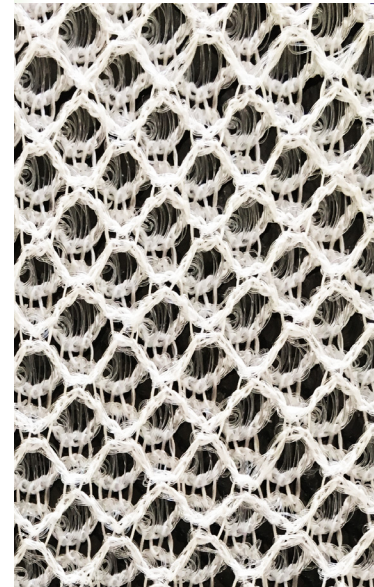

WavTex means Simplicity

WavTex requires no in basin retention or drain screens and can be used with existing fine bubble diffuser grids for maximum energy efficiency and minimum retrofit costs.

Entex Technologies Inc
400 Silver Cedar Court
Suite 200
Chapel Hill, NC 27514

919.933.2770 phone
919.287.2258
entexinc.com

WavTex by ENTEX Technologies, continued

WavTex means Versatility

Unlike traditional moving media systems, WavTex moving flex media can be used effectively in both fine bubble and coarse bubble systems, without the need to remove existing efficient fine bubble diffuser systems.

Increase capacity & biomass

WavTex moving flex media provides extensive surface area for biomass growth. The attached biomass population can more than double the effective MLSS concentration. The vigorous motion of the EnTextile media in the aeration basin provides a high shear on the surface of the EnTextile media, maintaining a thin biological film. The thin film provides for high rate biological kinetics.

Eliminates Screening

Never worry about plugging of retention screens. The WavTex system also allows for a broader range of tank dimensions, since the system eliminates the potential for media “bunching” at the back end of long basins.

Nitrification & Denitrification

WavTex provides stable growth platforms for slow-growing nitrifiers. Nitrifying plants perform better; non-nitrifying plants are able to nitrify. Plants needing to convert to nitrification can do so at a far lower cost than adding basins.

High Performance Media

Developed based on over 20 years of experience using attached growth media for wastewater treatment, EnTextile media provides high biomass surface area designed to maximize random turbulence and open pathways to create optimum conditions for substrate and oxygen transfer while maintaining biomass density control.

Cost Effectiveness

WavTex improves water treatment with little or no addition of aeration basins or clarifiers. It's a significantly less expensive way to upgrade activated sludge plants.

Advanced Systems. Proven Solutions.

ENTEX engineers have been involved in hundreds of plant installations. We'd like to be involved in yours.

Features

- Double offset design reduces seal wear
- High quality, 316SS (CF8M) construction
- Heavy-duty, single piece cast & machined disc with integral mounting sleeve
- Reinforced Teflon (RPTFE) seat for expanded temperature range
- Spring-loaded seat cover for easier removal and replacement of the valve seat
- Adjustable stem packing without loading seats
- Integral ISO 5211 direct mounting pad eliminates additional mounting brackets
- Integral disc stop prevents overtravel
- Stainless steel, single piece shaft
- Optional 10 position locking hand lever for 3 and 4" sizes
- Optional hand wheel gear operator for 3-8" sizes
- Pressure-rated 285psi

Applications

High performance wafer butterfly valves are used to control the flow of water, oils, air, certain caustics, and other media compatible with the materials of construction for general service and where an expanded temperature range or higher pressure is required.

Temperature Range

RPTFE Seals: -20 to 500°F (-29 to 260°C)

Construction

Valve Body	316 stainless steel CF8M
Disc	316 stainless steel CF8M
Disc Seat/Liner - Options	RPTFE
Stem Seals	V-ring (same material as seat)
Stem	17-4PH/316SS
Bearings	RPTFE
Fasteners	Stainless Steel



Operation

Direct mount wafer butterfly valves can be easily fitted with optional manual operator, air actuator or electric actuator using standard ISO5211 top mounting. Rotating the square stem one quarter turn moves the stainless steel disc and open or closes the valve.

Description

High Performance Wafer butterfly valves with 316 Stainless Steel body are designed to control various media in commercial and industrial applications. Valve mounts between two standard ANSI/ASME Class 125/ 150 and other international flanges. Disc is precision machined 316SS. Flange gaskets required.

Standards

- ANSI/ASME B16.5 CLASS150
- ANSI/ASME B16.1 CLASS125
- EN1092 PN10, PN16
- JIS B 2239 10K, 16K

Options

- Hand lever with 10 position locking (3-4")
- Gear Operators (3-8")
- Air Actuators
- Electric Actuators
- High Temperature Brackets

Construction Features

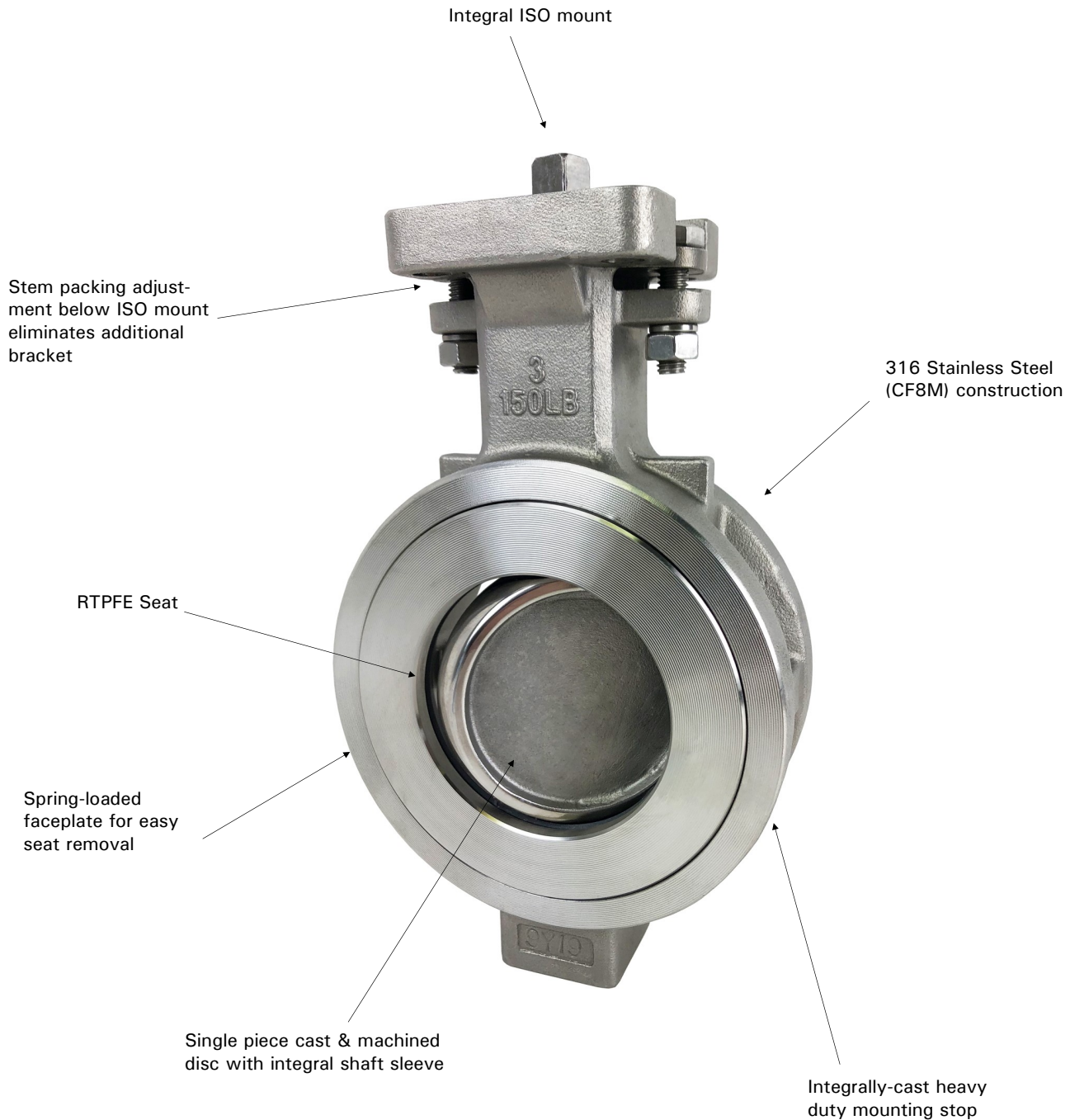

Specifications (English units)

Stock	Pipe Size	Orifice	Cv Flow	Pressure**	Fluid Media*	Body	Disc
Wafer Body EPDM Seals: BARE STEM (no handle)							
569003	3	2.9	165	285	Air, oil and other fluids compatible with materials of construction	316SS (CF8M)	316SS
569004	4	3.8	400	285	Air, oil and other fluids compatible with materials of construction	316SS (CF8M)	316SS
569006	6	5.6	1050	285	Air, oil and other fluids compatible with materials of construction	316SS (CF8M)	316SS
569008	8	7.4	2200	285	Air, oil and other fluids compatible with materials of construction	316SS (CF8M)	316SS

Cv = The GPM of water at 60° F that will pass through the valve with 1 PSI pressure drop

* Consult compatibility chart for other fluid media. Suitable for vacuum up to 29 inHg

* See P/T Chart

Specifications (Metric units)

Stock Number	Pipe Size (DN)	Orifice Diam. (mm)	Kv Flow Factor	Pressure** Max.(Bar)	Fluid Media*	Body	Disc
Wafer Body EPDM Seals: BARE STEM (no handle)							
569003	80	73.7	143	19.7	Air, oil and other fluids compatible with materials of construction	316SS (CF8M)	316SS
569004	100	96.5	346	19.7	Air, oil and other fluids compatible with materials of construction	316SS (CF8M)	316SS
569006	150	142.2	908	19.7	Air, oil and other fluids compatible with materials of construction	316SS (CF8M)	316SS
569008	200	188.0	1903	19.7	Air, oil and other fluids compatible with materials of construction	316SS (CF8M)	316SS

Kv = The number of m³ per hour of 20° C water at 1 bar pressure drop

* Consult compatibility chart for other fluid media. Suitable for vacuum up to 29 inHg

* See P/T Chart

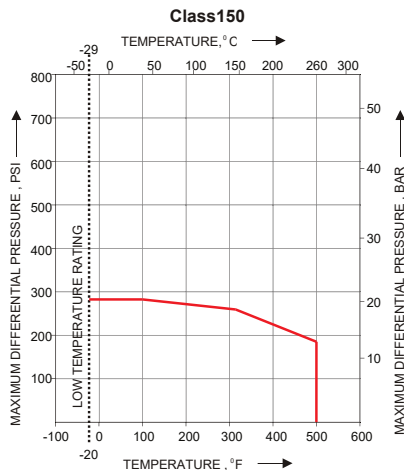

Rated value for 150 Lb body			
Temperature °F	Temperature °C	CF8M (PSI)	CF8M (bar)
-20.2 to 100.4	-29 to 38	275.6	19.0
199.4	93	235.0	16.2
300.2	149	214.7	14.8
399.2	204	194.4	13.4
500	260	169.7	11.7

Dimensions

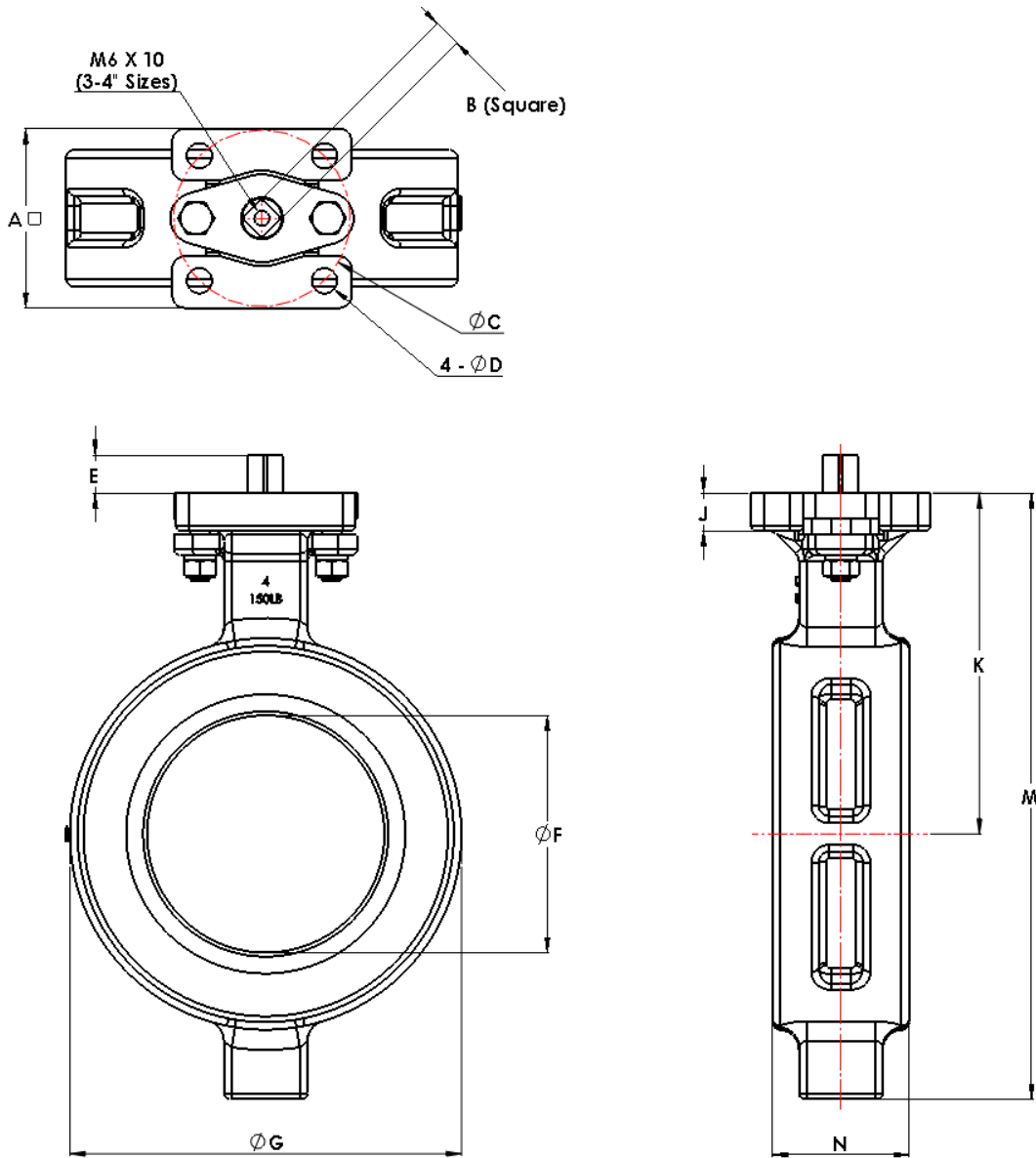

Pipe Size		A	B	C	D	E	F	G	J	K	M	N	ISO	Weight
3	inch	2.8	0.4	2.8	0.4	0.6	2.8	5.2	0.4	4.8	8.3	1.9	F07	9.7 lb
DN80	mm	70.0	11.0	70.0	10.0	15.0	72.0	131.0	11.0	122.0	212.0	49.0		4.4 kg
4	inch	2.8	0.4	2.8	0.4	0.6	3.7	6.1	0.6	5.3	9.4	2.1	F07	12.9 lb
DN100	mm	71.0	11.0	70.0	10.0	15.0	94.0	155.0	14.0	135.0	240.0	54.0		5.9 kg
6	inch	4.1	0.6	0.5	4.0	0.9	5.5	8.5	0.6	6.6	12.0	2.2	F10	25.4 lb
DN150	mm	103.0	14.0	12.0	102.0	23.0	140.0	216.0	16.0	168.0	300.0	57.0		11.5 kg
8	inch	4.1	0.7	0.5	4.0	0.9	7.3	10.6	0.6	7.8	14.6	2.5	F17	37.8 lb
DN200	mm	103.0	17.0	12.0	102.0	24.0	185.0	270.0	16.0	199.0	371.0	64.0		17.1 kg

Valve Seating Torques (inch lbs)

SIZE	Standard Disc Differential Pressure (PSI)		
	100	200	285
3	25	27	29
4	35	39	43
6	72	83	93
8	121	142	160

Valve Seating Torques (nm)

SIZE	Standard Disc Differential Pressure (Bar)		
	6.9	13.8	19.7
DN80	34	37	39
DN100	47	53	58
DN150	97	113	126
DN200	164	193	217

Torques shown are for on-off "wet" service (ex: water), for dry service (ex: air) multiply above values by 1.25, or see below. Valve disc turned clockwise and actuated at least once per month. The effect of dynamic torque is not considered in calculation.

Typical Wafer Valve Installation

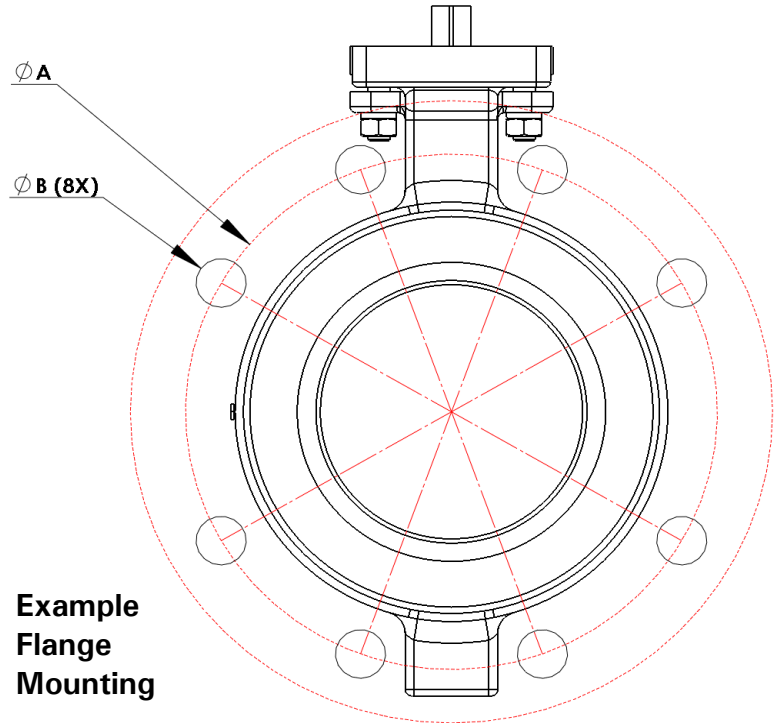

Example
Flange
Mounting

Valve suitable between flanges:

- ◆ ANSI/ASME B16.5 CLASS150
- ◆ ANSI/ASME B16.1 CLASS125
- ◆ EN1092 PN10, PN16
- ◆ JIS B 2239 10K, 16K
- ◆ BS 10 Table D, Table E

Pipe Size		A	B (8X)
3	inch	6	0.7
	mm	152.4	18
4	inch	7.5	0.7
	mm	190.5	18
6	inch	9.5	0.9
	mm	241.3	22
8	inch	11.8	0.9
	mm	298.5	22

Example Valve Torque Service and Medium Factors

SERVICE FACTOR (SF)	Multiply by	Medium Factor (MF)	Multiply by	Medium Factor (MF)	Multiply by
ON/OFF operation	1.15	Lubricating liquid/gas	0.90	For dry service (dry gas/air)	1.25
Modulating operation	1.25	Viscous liquids/molasses	1.30	Dirty air slurry, natural gas, dirty slurry	1.50-1.80
*2 cycle/day "NC"	1.15	Degreasing liquid	1.25	Lime water, powder	1.50-1.80
**1 cycle/week "NC"	1.50	Saturated steam	1.20	Hydrodynamic torque	N/A

* Valve normally remains completely closed (NC), and is opened 2 times a day minimum.

** Valve normally remains completely closed (NC), and is opened only one time per week or less.

Having a long period without cycling the valve will increase the breakaway torque.

Only choose one Service Factor (SF) and one Medium Factor (MF) when calculating the sizing torque.

Typical Wafer Valve Installation

- Always keep the valve closed during installation and disassembly
- The piping must have a straight line and the flanges have to be parallel.
- The distance between the flange must correspond to the face-to-face dimensions of the butterfly valve.
- The installation direction of the butterfly valve needs to be based on the flow direction arrow on the body.
- Before commissioning, the pipework has to be rinsed out to remove dirt and remnants of welding material, to avoid damage to the liner. During the rinsing procedure, the butterfly valve has to be positioned as open and may not be operated before the rinsing has been completed.
- Welding operations may not be performed near the butterfly valve, as welding drops can damage the liner.
- When installing and disassembling, the pipe must be completely relieved of pressure to avoid injury to people or damage to equipment.
- Where vacuum, high flow rate or water hammering can occur, flanges without a loose collar should be used.
- Carefully place the gasket between the flanges and place them in the center of the pipe to ensure a good seal. (see Fig.1)
- Place the valve between the gaskets and make sure the valve disc is parallel to the flange.
- Tighten the flange bolts in a diagonally opposite way to ensure that the valve is evenly stressed. (see Fig.2)
- After the installation is complete, carefully open and close the valve to ensure smooth operation.

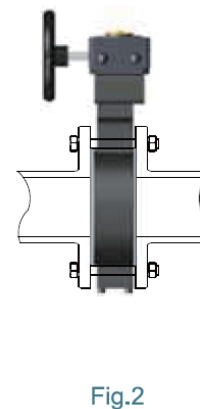
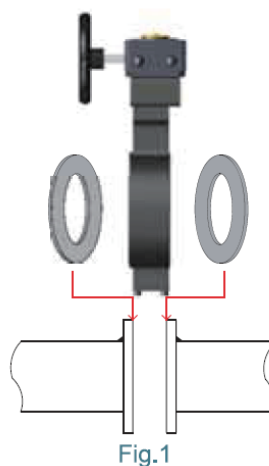

Seat Liner Resistance to Media

* Many conditions can affect the valve material choices, including: pressure, temperature, chemical mix, material compounding, viscosity and environment. Ultimately it is the user's responsibility to ensure valve materials are suitable for any specific purpose.

Features

- Stainless steel construction
- 10 position locking handle
- Convenient installation and usage
- 304SS bolts and nuts

Application

Hand lever operator for high performance butterfly valves. The valve disc can be locked in any one of 10 positions with spring loaded lever. Hand lever kit includes lever, gear locking plate and stainless hardware for mounting.



Specifications

Stock No.	Description
565020	Hand lever for valve sizes 3-4", stainless steel

Dimensions

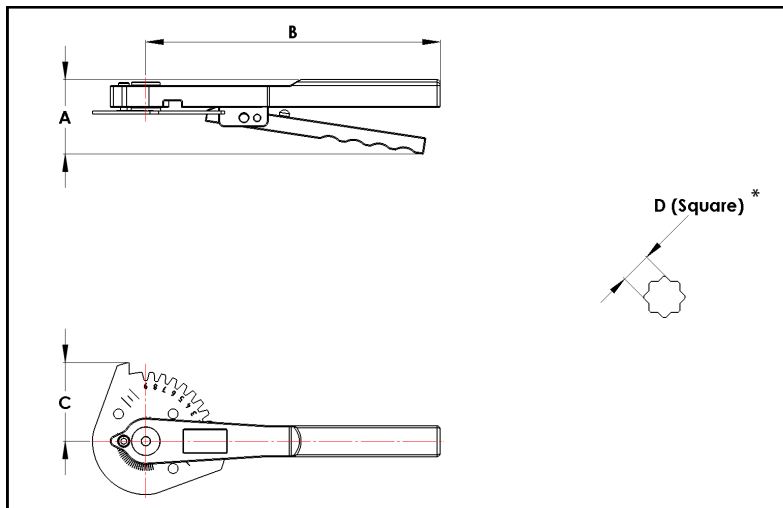

*14x11 square reducer included

Pipe Size		A	B	C	D	ISO	Weight
3-4	inch	3.7	10.5	2.9	14x14	F07	1.8 lbs
	mm	95.0	267.0	73.0			0.8 kg

Features

- Double offset design reduces seal wear
- High quality, 316SS (CF8M) valve body, disc, and stem
- Reinforced Teflon (RTPFE) seats for expanded temperature range
- Heavy-duty, single piece cast & machined disc with integral mounting sleeve
- Spring loaded seat cover for easier removal and replacement of the valve seat
- Visual valve position indicator
- Rugged aluminum Type 4X weatherproof enclosure
- Heavy duty motors with overload protection
- Thermostatically controlled anti-condensation heater
- Manual override with end of travel mechanical stops
- Two auxiliary position confirmation limit switches
- EPS - Electronic Positioning System models available
- Actuators CSA Listed per UL429 and CSA C22.2

Applications

High performance wafer butterfly valves are used to control the flow of waters, oils, air, certain caustics, and other media compatible with the materials of construction for general service and where an expanded temperature range or higher pressure is required. Actuators designed for 70% duty cycle.

Operation

On-Off electric actuated valve uses power-to-open and power-to-close, stays in the last known position with loss of power. On receipt of a continuous voltage signal, the motor runs and via a rugged all metal gear system rotates the ball 90°. The motor is automatically stopped by internal cams striking limit switches. On receipt of a reversing continuous signal, the motor turns in the opposite direction reversing the valve position. Power connections direct to terminal strip via included cable connector, or optional 1/2" NPT conduit adapters.

Construction

Valve Body	316 stainless steel CF8M
Disc	316 stainless steel CF8M
Disc Seat/ Liner	RPTFE
Stem/ Stem Seals	17-4PH/316SS/ V-ring (same material as seat)
Gear Drive	Heavy duty alloy steel/ aluminum bronze, self locking
Actuator Enclosure	Aluminum, polyester powder painted, Type 4X, IP67
Visual Valve Position Indicator	Clear Polycarbonate cover, red/yellow open-closed
Fasteners	Stainless Steel
Auxiliary Limit Switches	2 x SPDT (5A/125VAC), on-off actuators only



Description

Electric operated direct mount high performance butterfly valves with 316 stainless steel wafer body are designed for commercial and industrial applications. Valve mounts between two standard ANSI/ASME Class 125/150 flanges. Disc is precision machined 316SS. Double offset design to reduce seal wear. Rugged corrosion resistant electric actuator includes a manual override, valve position confirmation switches (on-off units), thermostatically controlled anti-condensation heater, and over-torque protection.

Approvals

Actuators

- CSA Listed to:
 - UL429 and CSA C22.2 no 139
 - Type 4X, IP67 weatherproof enclosure
- CE conformance
 - ISO5211 Mounting



Valves– Standards

- ANSI/ASME B16.5 CLASS150
- ANSI/ASME B16.1 CLASS125
- EN1092 PN10, PN16
- JIS B 2239 10K, 16K

Construction Features



Visual Valve Position Indicator

Pressure Rating

Pressure Rating: 285 PSI (19.7 Bar)

Temperature Rating

Actuator Temperature Rating: -13 to 131° F (-25 to 55° C)

Valve Temperature Rating: RPTFE seals: -20 to 500° F (-29 to 260°C)

Specifications (English units)

Stock Number	Pipe Size (inch)	Orifice Diam. (inch)	Cv Flow Factor	Pressure Max. (PSI)	Cycle Time/90° (seconds)	Voltage	Current (amps)	Duty Cycle	Electrical Dwg.
120 VAC ELECTRIC ACTUATED HIGH PERFORMANCE WAFER BODY BUTTERFLY VALVE, RPTFE SEALS									
569103	3	2.9	165	285	30/25	110 VAC, 50/60Hz	0.6	70%	B
569104	4	3.8	400	285	30/25	110 VAC, 50/60Hz	0.6	70%	B
569106	6	5.6	1050	285	30/25	110 VAC, 50/60Hz	0.7	70%	B
569108	8	7.4	2200	285	45/37	110 VAC, 50/60Hz	1.3	70%	B
24 VDC ELECTRIC ACTUATED HIGH PERFORMANCE WAFER BODY BUTTERFLY VALVE, RPTFE SEALS									
569303	3	2.9	165	285	30	DC24	2.0	70%	G
569304	4	3.8	400	285	30	DC24	3.6	70%	G
569306	6	5.6	1050	285	30	DC24	3.6	70%	G

Cv = The GPM of water at 60° F that will pass through the valve with 1 PSI pressure drop

* Consult compatibility chart for other fluid media. Suitable for vacuum up to 29 inHg

* See P/T Chart

Specifications (Metric units)

Stock Number	Pipe Size	Orifice	Kv Flow	Pressure	Cycle Time/90°	Voltage	Current	Duty	Electrical
120 VAC ELECTRIC ACTUATED HIGH PERFORMANCE WAFER BODY BUTTERFLY VALVE, RPTFE SEALS									
569103	80	73.7	143	19.7	30/25	110 VAC, 50/60Hz	0.6	70%	B
569104	100	96.5	346	19.7	30/25	110 VAC, 50/60Hz	0.6	70%	B
569106	150	142.2	908	19.7	30/25	110 VAC, 50/60Hz	0.7	70%	B
569108	200	188.0	1903	19.7	45/37	110 VAC, 50/60Hz	1.3	70%	B
24 VDC ELECTRIC ACTUATED HIGH PERFORMANCE WAFER BODY BUTTERFLY VALVE, RPTFE SEALS									
569303	80	73.7	143	19.7	30	DC24	2.0	70%	G
569304	100	96.5	346	19.7	30	DC24	3.6	70%	G
569306	150	142.2	908	19.7	30	DC24	3.6	70%	G

Kv = The number of m³ per hour of 20° C water at 1 bar pressure drop

* Consult compatibility chart for other fluid media. Suitable for vacuum up to 29 inHg

* See P/T Chart

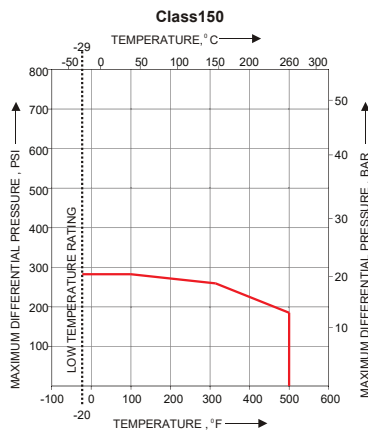

Rated value for 150 Lb body			
Temperature °F	Temperature °C	CF8M (PSI)	CF8M (bar)
-20.2 to 100.4	-29 to 38	275.6	19.0
199.4	93	235.0	16.2
300.2	149	214.7	14.8
399.2	204	194.4	13.4
500	260	169.7	11.7

Electrical Wiring

AC Voltages

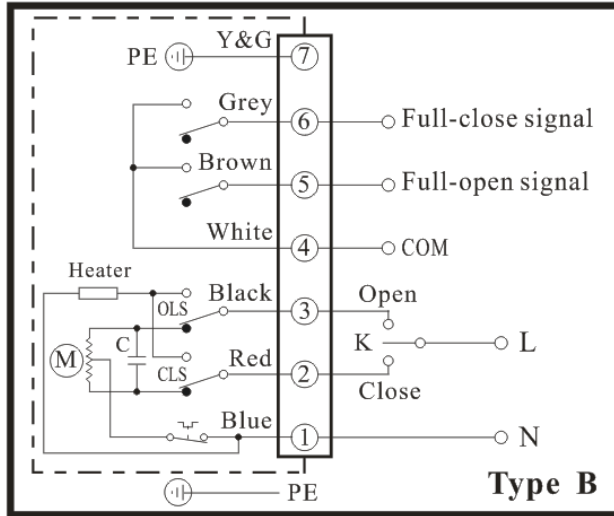

DC Voltages

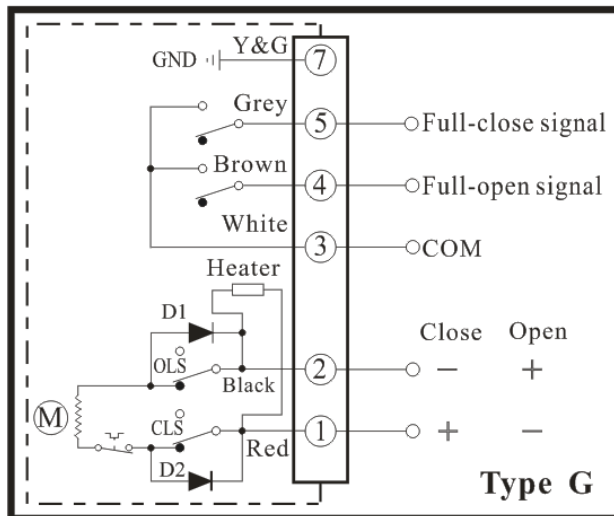

Dimensions: (110AC)

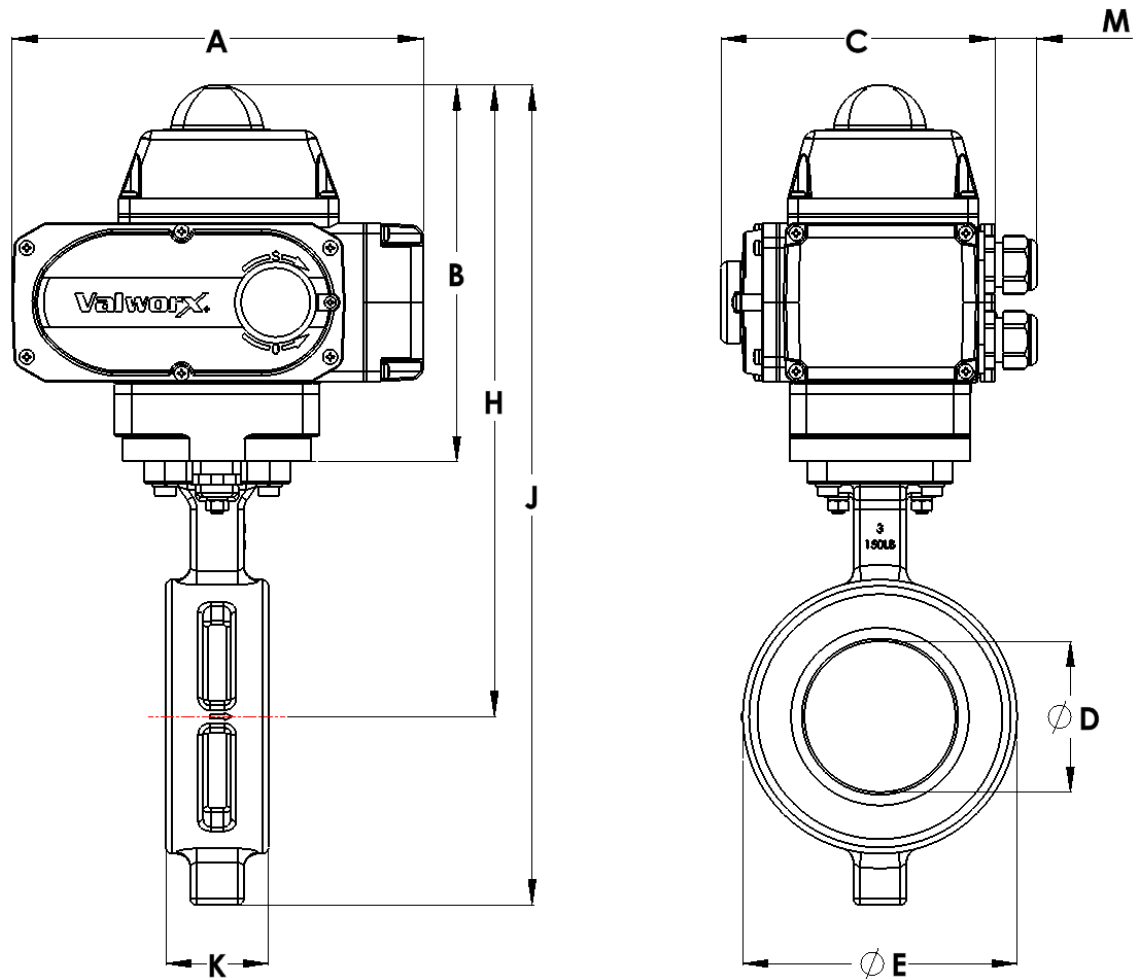

Suitable between flanges:

- ◆ ANSI/ASME B16.5 CLASS150
- ◆ ANSI/ASME B16.1 CLASS125
- ◆ EN1092 PN10, PN16
- ◆ JIS B 2239 10K, 16K
- ◆ BS 10 Table D, Table E

Pipe Size		A	B	C	D	E	H	J	K	M	Weight (AC)
3	inch	7.7	7.1	5.0	2.8	5.2	11.9	15.4	1.9	1.0	18.7 lb
	mm	195.6	180.3	127.0	72	131	302.3	391.2	49	25.4	8.4 kg
4	inch	7.7	7.1	5.0	3.7	6.1	12.4	16.5	2.1	1.0	21.9 lb
	mm	195.6	180.3	127.0	94	155	315.0	419.1	54	25.4	9.9 kg
6	inch	10.1	8.5	6.4	5.5	8.5	15.1	20.5	2.2	1.0	45.4 lb
	mm	256.5	215.9	162.6	140	216	383.5	520.7	57	25.4	20.5 kg
8	inch	10.1	8.5	6.4	7.3	10.6	16.3	23.1	2.5	1.0	57.8 lb
	mm	256.5	215.9	162.6	185	270	414.0	586.7	64	25.4	26.1 kg

Dimensions: (24DC)

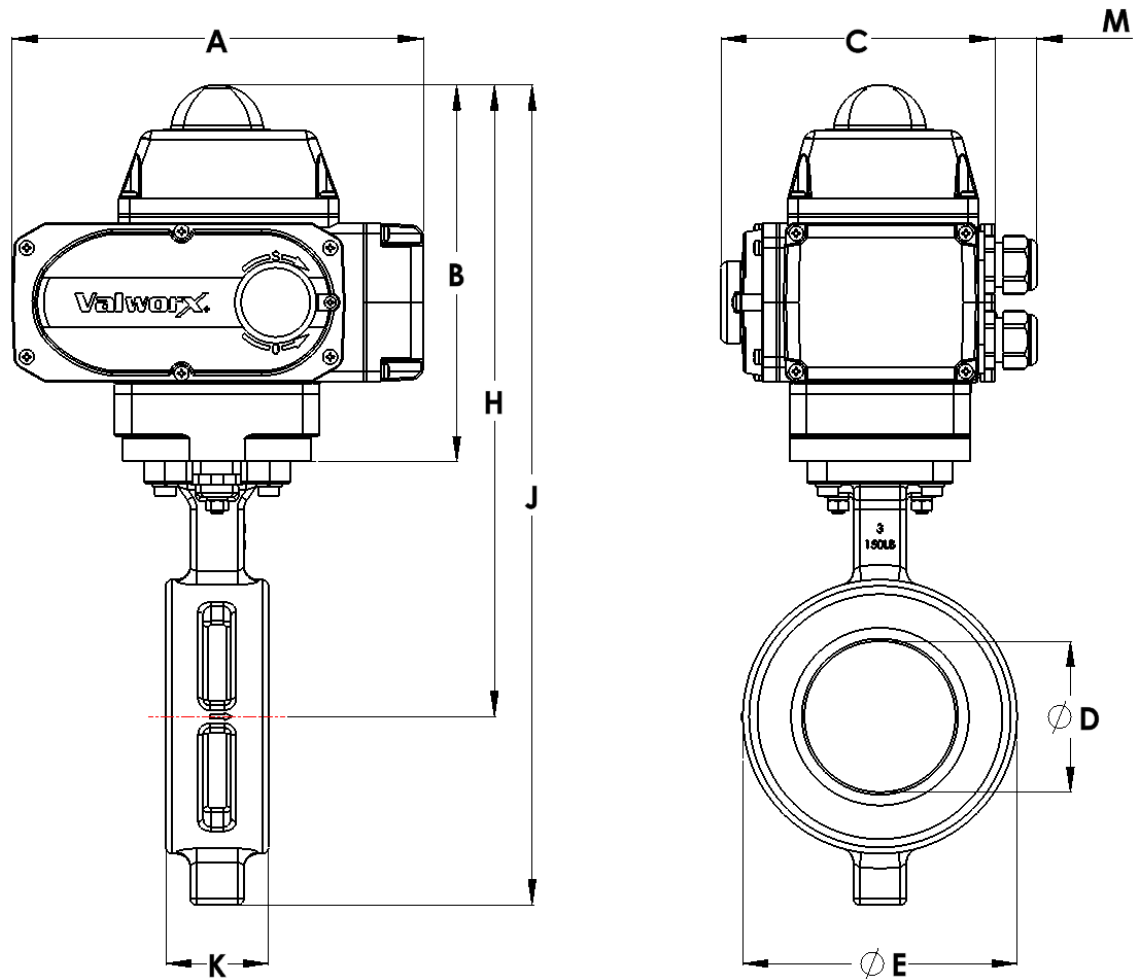

Suitable between flanges:

- ◆ ANSI/ASME B16.5 CLASS150
- ◆ ANSI/ASME B16.1 CLASS125
- ◆ EN1092 PN10, PN16
- ◆ JIS B 2239 10K, 16K
- ◆ BS 10 Table D, Table E

Pipe Size		A	B	C	D	E	H	J	K	M	Weight (DC)
3 DN80	inch	7.7	7.1	5.0	2.8	5.2	11.9	15.4	1.9	1.0	18.7 lb
	mm	195.6	180.3	127.0	72	131	302.3	391.2	49		8.4 kg
4 DN100	inch	10.1	8.5	6.4	3.7	6.1	13.8	17.9	2.1	1.0	21.9 lb
	mm	256.5	215.9	162.6	94	155	350.5	454.7	54		9.9 kg
6 DN150	inch	10.1	8.5	6.4	5.5	8.5	15.1	20.5	2.2	1.0	45.4 lb
	mm	256.5	215.9	162.6	140	216	383.5	520.7	57		20.5 kg

PROFESSIONAL SERVICES AGREEMENT
between
(Service Provider Name)
And
MIDWEST CITY MUNICIPAL AUTHORITY

THIS PROFESSIONAL SERVICES AGREEMENT (hereinafter referred to as “**Agreement**”) is entered into by and among The Midwest City Municipal Authority, a public trust created pursuant to Oklahoma State Law for the benefit of Midwest City (hereinafter referred to as “**Authority**”), and (SERVICE PROVIDER NAME), (hereinafter referred to as “**Service Provider**”) (**Authority**, and **Service Provider** being collectively referred to herein as the “**Parties**”) and is effective upon the date of execution by the last party hereto.

WITNESSETH:

WHEREAS, Authority is in need of the following professional services to drain and clean the West Reactors of the Moving Bed Biofilm Reactor (MBBR) and install two WavTex modules; and

WHEREAS, Service Provider is in the business of providing professional services that is needed by the **Authority**; and

WHEREAS, the Authority and the **Service Provider** have reached an agreement for the **Service Provider** to provide the **Authority** the requested professional services; and

WHEREAS, Authority hereby retains **Service Provider** to provide professional services as an independent contractor; and

WHEREAS, Service Provider agrees to provide the **Authority** all services, in accordance with the standards exercised by experts in the field, necessary to provide the **Authority** services, products, solutions and deliverables that meet all the purposes and functionality requested or described in this Agreement.

NOW, THEREFORE, for and in consideration of the above premises and mutual covenants as set forth herein, the **Authority**, and **Service Provider** hereby agree as follows:

1. Services, Products, Solutions and Deliverables

Subject to the terms and conditions of this Agreement, the Authority retains the Service Provider as an independent contractor, to provide **Authority** all services, in accordance with the standards exercised by experts in the field, necessary to provide the Authority

PROFESSIONAL SERVICES AGREEMENT
between
(Service Provider Name)
And
MIDWEST CITY MUNICIPAL AUTHORITY

services, products, solutions, and deliverables (collectively referred to as “Deliverables”) that meet all the purposes and functionality requested or described in this Agreement. The Authority shall meet with Service Provider to identify service needs on a project by project basis. Service Provider will provide a written proposal for the identified services in accord with the terms and conditions of this Agreement. The Authority may issue a purchase order for the identified services accompanied by Service Provider’s written proposal. Upon issuance of the purchase order, the Service Provider shall be responsible for timely providing the services authorized by the purchase order (“Project”). Upon completion of the Project (services in a purchase order), the Service Provider will issue an invoice to the Authority and, upon approval of the invoice, the Authority will pay the invoice. Upon completion of each Project and provision to the Authority of all Deliverables for that Project and payment of the invoice for that Project to the Service Provider, the Authority shall own all rights and license for the Deliverables and other work products related to that Project.

a) This Agreement governs the Scope of Services including, but not limited to, all Deliverables to be provided by Service Provider to the Authority. The Attachments are incorporated into this Agreement by reference and, should there be a conflict in language, terms, conditions, or provisions, shall have the priority and precedential value as set forth in this Agreement.

b) The text of this Agreement together with the Attachments constitutes the entire Agreement and the only understanding and agreement between the Authority and the Service Provider with respect to the services, products, solutions and deliverables to be provided by the Service Provider hereunder. This Agreement may only be amended, modified or changed in writing when signed by all parties, or their respective specifically authorized representatives, as set forth in this Agreement.

c) If there is a conflict in language, terms, conditions, or provisions, in this Agreement

PROFESSIONAL SERVICES AGREEMENT
between
(Service Provider Name)
And
MIDWEST CITY MUNICIPAL AUTHORITY

between the text of this document, and any language, term, condition, or provision in any Attachment, then the text of this document, shall govern and control over any conflicting language, term, condition, or provision in any Attachment. As among the Attachments any conflict in the language, terms, conditions, or provisions shall be governed in the following order of priority and precedence:

- Attachment “A” (“Scope of Services”)
- Attachment “B” (“Schedule of Fees / Rate Card”),
- Attachment “C” (“**Service Provider’s Team**”),
- Attachment “D” (“Insurance”).

2. RETENTION OF SERVICES PROVIDER AND SCOPE OF SERVICES

A. **Service Provider** is solely responsible for the actions, non-action, omissions, and performance of **Service Provider’s** employees, agents, contractors, and subcontractors (herein collectively included in the term “Service Provider’s Project Team”) and to ensure the timely provision of each Project, timely performance of the Scope of Services, and the timely performance of each Project and the provision of all Deliverables as each are defined in **Attachment “A” (“Scope of Services”)** or the Project.

B. **Service Provider** will be solely responsible to ensure the **Service Provider’s Project Team** fully understands each Project, the Scope of Services, the Deliverables, the schedule for performance, and **Authority’s** goals and purposes. Service Provider will be solely responsible to ensure the **Service Provider’s Team**, specifically assigned to work on the Project for the Authority, is adequately trained, instructed, and managed so that **Service Provider** timely provides each Project task and satisfies the **Service Provider’s** obligations under this Agreement. The **Service Provider** may not change the **Service Provider’s Team**, for the services to be provided as set forth on Attachment “C” (“**Service Provider’s Team**”) without the prior written consent of the **Authority**.

PROFESSIONAL SERVICES AGREEMENT
between
(Service Provider Name)
And
MIDWEST CITY MUNICIPAL AUTHORITY

C. **Service Provider** shall comply with all applicable federal, state and local laws, standards, codes, ordinances, administrative regulations and all amendments and additions thereto, pertaining in any manner to the performance or services provided under this **Agreement**. **Service Provider** shall obtain all patents, licenses and any other permission required to provide all Deliverables and for use of all Deliverables by the **Authority**.

3. CONSIDERATION

A. The **Authority** shall pay the **Service Provider** the compensation after completion of Projects or Deliverables as specified in **Attachment “B” (“Schedule of Fees / Rate Card”)**.

B. The **Authority** and the **Service Provider** acknowledge that the compensation to be paid the **Service Provider** pursuant to this **Agreement** has been established at an amount reasonable for the availability and services of the **Service Provider and the Service Provider’s** Team.

4. INDEPENDENT CONTRACTOR STATUS

The parties hereby acknowledge and covenant that:

A. **Service Provider** is an independent contractor and will act exclusively as an independent contractor is not an agent or employee of the **Authority** in performing the duties in this Agreement.

1. The parties do not intend, and will not hold out that there exists, any corporation, joint venture, undertaking for a profit or other form of business venture or any employment relationship among the parties other than that of an independent contractor relationship.

2. All payments to **Service Provider** pursuant to this **Agreement** shall be due and payable in the State of Oklahoma, even if services of **Service Provider** are performed outside the State of Oklahoma.

PROFESSIONAL SERVICES AGREEMENT
between
(Service Provider Name)
And
MIDWEST CITY MUNICIPAL AUTHORITY

B. The **Authority** shall not withhold any social security tax, workmen's compensation, Medicare tax, federal unemployment tax, federal income tax, or state income tax from any compensation paid to **Service Provider** as **Service Provider** is an independent contractor and the members of its **Service Provider's Team**, assigned to work on the Project for the **Authority** are not employees of the **Authority**. Any such taxes, if due, are the responsibilities of **Service Provider** and will not be charged to the **Authority**.

C. **Service Provider** acknowledges that as an independent contractor it and **Service Provider's Project Team**, assigned to work on the Project for the **Authority** are not eligible to participate in any health, welfare or retirement benefit programs provided by the **Authority** or its employees.

5. TERM, TERMINATION AND STOP WORK

A. This **Agreement** shall commence upon execution by the last party hereto and shall continue in effect for one-year from the date of execution, unless terminated by either party as provided for herein. This **Agreement** may be extended by mutual agreement of the **Parties** in one-year increments, until the Project is completed and accepted as provided herein.

B. The **Authority** issue notices of termination or suspension to the **Service Provider**. This **Agreement** may be terminated, with or without cause, upon written notice, at the option of **Authority**.

1. Upon receipt of a notice of termination for *convenience* from the **Authority**, the **Service Provider** shall immediately discontinue all services and activities (unless the notice directs otherwise), and

2. Upon payment for products or services fully performed and accepted, **Service Provider** shall deliver to the **Authority** all licenses, work, products, deliverables, solutions, communication recommendations, plans, messaging strategies, style guides, design elements, internal and external messaging campaigns, documents, data analysis, reports, and other information and materials accumulated or created in performing this **Agreement**, whether same

PROFESSIONAL SERVICES AGREEMENT
between
(Service Provider Name)
And
MIDWEST CITY MUNICIPAL AUTHORITY

are complete or incomplete, unless the notice directs otherwise. Upon termination for the *convenience* by the **Authority**, the **Authority** shall pay **Service Provider** for completed Projects and Deliverables up to the time of the notice of termination for *convenience*, in accordance with the terms, limits and conditions of the **Agreement** and as further limited by the “not to exceed” amounts set out in this **Agreement**.

3. Upon notice of termination for *cause* from the **Authority**, the **Service Provider** shall not be entitled to any prior or future payments, including, but not limited to, any services, performances, work, products, deliverables, solutions, costs, or expenses, and **Service Provider** shall release and waive any interest in any retainage. The **Authority** may hold any outstanding payments for prior completed Projects, Deliverables, Services or expenses and any retainage as security for payment of any costs, expenses, or damages incurred by the **Authority** by reason of **Service Provider’s** breach or other cause. Provided, however, upon notice of termination for cause, the **Service Provider** shall deliver to the **Authority** services, products, solutions, and Deliverables including, but limited to, all communication recommendations, plans, messaging strategies, style guides, design elements, internal and external messaging campaigns, documents, data analysis, reports, and other information and materials accumulated or created in performing this **Agreement**, whether complete or incomplete, unless the notice directs otherwise.

4. The rights and remedies of the **Authority** provided in this paragraph are in addition to any other rights and remedies provided by law or under the **Agreement**. Termination herein shall not terminate or suspend any warranty, indemnification, insurance, or confidentiality required to be provided by **Service Provider** under this **Agreement**.

C. Upon notice to **Service Provider**, the **Authority** may issue a stop work order suspending any Projects, services, performances, work, products, Deliverables, or solutions under this **Agreement**. Any stop work order shall not terminate or suspend any warranty, indemnification, insurance, or confidentiality required to be provided by **Service Provider** under

PROFESSIONAL SERVICES AGREEMENT
between
(Service Provider Name)
And
MIDWEST CITY MUNICIPAL AUTHORITY

this **Agreement**. In the event the **Authority** issues a stop work order to **Service Provider**, the **Authority** will provide a copy of such stop work order to the **Service Provider**. Upon receipt of a stop work order issued from the **Authority**, the **Service Provider** shall suspend all work, services and activities except such work, services, and activities expressly directed by the **Authority** in the stop work order. Upon notice to the **Service Provider**, this **Agreement**, and any or all work, services, and activities thereunder, may be suspended up to thirty (30) calendar days by the **Authority**, without cause and without cost to the **Authority**; provided however, the **Service Provider** shall be entitled to an extension of all subsequent deadlines for a period equal to the suspension periods for those suspended work, services, and activities only.

D. Obligation upon Termination for Convenience.

1. In the event this **Agreement** is terminated for convenience hereunder, the **Authority** shall pay **Service Provider** for such properly documented invoices, if any, in accordance with the provisions of this **Agreement** above, through the date of termination for *convenience* and the period set forth in the notice, and thereafter the **Authority** shall have no further liability under this **Agreement** to **Service Provider** and **Service Provider** shall have no further obligations to the **Authority**.

2. Upon termination for *convenience* of the Project and the providing to the **Authority** of all Deliverables for the Project and payment of the invoice for the Project to **Service Provider**, the **Authority** shall own all rights and license for the Deliverables and other work products related to that Project.

6. WARRANTIES

A. **Service Provider** warrants that the Projects performed and Deliverables provided under this **Agreement** shall be performed consistent with generally prevailing professional standards and expertise. **Service Provider** shall maintain during the course of this **Agreement** said standard of care, expertise, skill, diligence and professional competency for any and all such services, products, solutions and deliverables. **Service Provider** agrees to require all

PROFESSIONAL SERVICES AGREEMENT
between
(Service Provider Name)
And
MIDWEST CITY MUNICIPAL AUTHORITY

members of the **Service Provider’s Team**, also including FTEs assigned to work on the Project, to provide any and all services, products, solutions and Deliverables at said same standard of care, expertise, skill, diligence and professional competence required of **Service Provider**.

B. During the term of this **Agreement**, the **Authority’s** initial remedy for any breach of the above warranty shall be to permit **Service Provider** one additional opportunity to perform the work, services, and activities or provide the Projects and Deliverables without additional cost to the **Authority**. If the **Services Provider** cannot perform the work, services, and activities or provide the products, solutions and deliverables according to the standards and requirements set forth in this **Agreement** within thirty (30) calendar days of the original performance date, the **Authority** shall be entitled to recover, should the **Authority** so determine to be in their best interest, any fees paid to the **Service Provider** for previous payments, including, but not limited to, work, services, activities services, Projects and Deliverables and **Service Provider** shall make reimbursement or repayment within thirty (30) calendar days of a demand by the **Authority**. Should the **Service Provider** fail to reimburse the **Authority** within thirty (30) calendar days of demand, the **Authority** shall also be entitled to interest at 1.5% percent per month on all outstanding reimbursement and repayment obligations.

C. The **Service Provider** also acknowledges and agrees to provide all express and implied, warrants required or provided for by Oklahoma statutory and case law. This warrant is in addition to other warranties provided in or applicable to this **Agreement** and may not be waived by any other provision, expressed or implied, in this **Agreement** or in any **Attachment** hereto.

7. INSURANCE

A. **Service Provider** must provide and maintain at all times throughout the term of this **Agreement**, and any renewal hereof, such *commercial general insurance with a limit of \$1,000,000 per occurrence for bodily injury and property damage and \$5,000,000 general aggregate* protecting the **Authority** from claims for bodily injury (*including death*) and or Professional Services Agreement with (Service Provider Name)

PROFESSIONAL SERVICES AGREEMENT
between
(Service Provider Name)
And
MIDWEST CITY MUNICIPAL AUTHORITY

property damage arising out of or resulting from the **Service Provider**, and its employees, use and occupancy of the premises and the activities conducted thereon . The insurance coverage required in this paragraph must include the **Authority** as additional insureds as their interest may appear under this **Agreement** under the policy or policies.

B. A certificate of insurance evidencing the coverage required herein shall be provided to the **Authority** within five (5) days of the execution of this **Agreement**.

C. **Service Provider** shall require any contractor or subcontractor to obtain and maintain substantially the same coverage as required of **Service Provider** including the **Authority** as an additional insured as their interest may appear under this **Agreement**.

D. The insurance requirements set forth herein must not be deemed to limit, affect, waive, or define any obligations of the **Service Provider** in any other paragraph of this **Agreement** or any indemnification or insurance requirement in any other paragraph of this **Agreement**. This paragraph must continue in full force and affect for any act, omission, incident or occurrence occurring or commencing during the term of this **Agreement**. Further, the insurance coverage required by this paragraph will survive revocation, non-renewal, termination and expiration of this **Agreement** for any occurrence or event occurring, initiated, or commencing prior to such revocation, non-renewal, termination and expiration or during the period in which the **Service Provider** is services under the **Agreement**.

E. Provided, however, should the **Service Provider** or its officers, invitees, representatives, contractors, employees or agents carry any additional, different or other insurance or insurance coverage of any kind or nature, the provisions of this paragraph must not in any way limit, waive or inhibit the **Authority** from making a claim or recovering under such insurance or insurance coverage.

F. Notwithstanding any other provision to the contrary, upon termination or lapse of insurance coverage required hereunder, this **Agreement** may be terminated. Termination of this **Agreement** pursuant to this paragraph must take precedence and supersede any other paragraph establishing the term of this **Agreement**, establishing a procedure for revocation or termination,

PROFESSIONAL SERVICES AGREEMENT
between
(Service Provider Name)
And
MIDWEST CITY MUNICIPAL AUTHORITY

or requiring notice and/or providing an opportunity to cure a breach.

G. The insurance limits in this paragraph in no way act or will be deemed to define or limit the right of **Authority** to recover damages, expenses, losses or for personal injuries, death or property damage pursuant to applicable law or the indemnification provisions or under any other paragraph or provision in this **Agreement**.

8. INDEMNIFICATION

A. **Service Provider** agrees to indemnify, defend, and hold harmless the **Authority** from and against all liability for: (a) injuries or death to persons; (b) costs, losses, and expenses; (c) legal fees, legal expenses, and court costs; and (d) damages, loss to property, which are caused by the **Service Provider**, its officers, representatives, agents, contractors, and employees except to the extent such injuries, losses, damages and/or costs are caused by the negligence or willful misconduct of the indemnified party. The **Service Provider** must give the **Authority** prompt and timely notice of any claim or suit instituted which in any way, directly or indirectly, contingently or otherwise, affects or might affect the **Authority**, provided, however, such notice will not be a precondition to indemnification hereunder. The rights granted by this paragraph will not limit, restrict, or inhibit the rights of the **Authority** under any other paragraph, including but not limited to any insurance provision or requirement in this **Agreement**.

B. The provisions of this paragraph shall survive the expiration of this **Agreement**. It is understood that these indemnities and hold harmless provisions are not limited or defined by the insurance required under the insurance provisions of this **Agreement**.

9. CONFIDENTIALITY

Service Provider acknowledges that in the course of training and providing other services to the **Authority**, the **Authority** may provide **Service Provider** with access to valuable information of a confidential and proprietary nature including but not limited to information relating to the **Authority's** employees, customers, marketing strategies, business processes and

PROFESSIONAL SERVICES AGREEMENT
between
(Service Provider Name)
And
MIDWEST CITY MUNICIPAL AUTHORITY

strategies, security systems, data and technology. **Service Provider** agrees that during the time period this **Agreement** is in effect, and thereafter, neither **Service Provider** nor **Service Provider's Team**, without the prior written consent of the **Authority**, shall disclose to any person, other than to the **Authority**, any information obtained by **Service Provider**. **Service Provider** shall require and maintain adequate confidentiality agreements with its employees, agents, contractors, and subcontractors.

10. NOTICES

A. Notices and other communications to the **Authority** pursuant to the provisions hereof will be sufficient if sent by first class mail, postage prepaid, return receipt required, or by a nationally recognized courier service, addressed to:

Midwest City Municipal Authority, Secretary for the Authority
100 N. Midwest Boulevard
Midwest City, OK 73110

AND

Midwest City Municipal Authority,
c/o City of Midwest City Public Works Authority
Attention: Director of Public Works
100 N. Midwest Boulevard
Midwest City, OK 73110

respectively, and notices or other communications to the **Service Provider** pursuant to the provisions hereof will be sufficient if by first class mail, postage prepaid, return receipt required, or by a nationally recognized courier service, addressed to:

(Contact Person name for Service Provider)

(Name of Service Provider)

(street or mailing address for service provider)

(Authority, State and zip code for service provider)

PROFESSIONAL SERVICES AGREEMENT
between
(Service Provider Name)
And
MIDWEST CITY MUNICIPAL AUTHORITY

B. Any party hereto may change the address or addressee for the giving of notice to it by thirty (30) days prior written notice to the other parties hereto as provided herein. Unless otherwise specified in this **Agreement**, notice will be effective upon actual receipt or refusal as shown on the receipt obtained pursuant to this paragraph.

11. ABIDES BY LAW

The **Service Provider** must abide by the conditions of this **Agreement**, the ordinances of the **Authority**, and all laws and regulations of the State of Oklahoma and the United States of America (“Laws”), applicable to **Service Provider’s** activities. **Service Provider** will be responsible for securing any license, permits and/or zoning which may be required prior to commencement of the Project.

12. ASSIGNMENT AND SUBLEASE

Service Provider may not assign or sublease its interest under this **Agreement** without the prior written consent of the **Authority**. Any assignment or sublease shall become effective upon receipt of a request signed by authorized and empowered officers/agents of the **Service Provider** and sublessee and provision by the sublessee of a certificate of insurance evidencing the insurance required by this **Agreement** and upon approval of such sublease by **Authority**. The **Authority** may, but not required, to execute a letter approving either the assignment or sublease as provided herein on behalf of **Authority**. Upon approval of such assignment or sublease, **Service Provider** will not be relieved of future performance, liabilities, and obligations under this **Agreement**. **Authority** shall be provided with a copy of each written sublease agreement, and all amendments thereto, entered into by **Service Provider** within forty-five (45) days after the entering into of same.

13. COMPLETE AGREEMENT AND AMENDMENT

This is the complete agreement between the parties and no additions, amendments, alterations, or changes in this **Agreement** shall be effective unless reduced to writing and signed

PROFESSIONAL SERVICES AGREEMENT
between
(Service Provider Name)
And
MIDWEST CITY MUNICIPAL AUTHORITY

by all parties hereto. Additionally, no statements, discussions, or negotiations shall be deemed or interpreted to be included in this **Agreement**, unless specifically and expressly provided herein.

14. TIME OF ESSENCE

For the purposes of this **Agreement**, time shall be deemed to be of the essence.

15. MULTIPLE ORIGINALS

This **Agreement** shall be executed in multiple counterparts, each of which shall be deemed an original.

16. ANTI-COLLUSION

Service Provider agrees that it has not been and shall not be a party to any collusion with any of their officials, trustees, or employees of the **Authority** as to the terms or conditions of this **Agreement**, and has not and will not exchange, give or donate money or other things of value for special consideration to any officials, trustees, or employees of the **Authority**, either directly or indirectly, in procuring and execution of this **Agreement**.

17. BREACH AND DEFAULT

A. A breach of any provision of this **Agreement** shall act as a breach of the entire **Agreement** unless said breach is expressly waived in writing by all other parties hereto. Failure to enforce or timely pursue any breach shall not be deemed a waiver of that breach or any subsequent breach. No waiver of any breach by any party hereto of any terms, covenants, or conditions herein contained shall be deemed a waiver of any subsequent breach of the same, similar, or different nature.

B. Further, except as otherwise specifically and expressly provided and any other paragraph hereto, should any party hereto fail to perform, keep or observe any of the terms, covenants, or conditions herein contained, this **Agreement** may be terminated by any party not in

PROFESSIONAL SERVICES AGREEMENT
between
(Service Provider Name)
And
MIDWEST CITY MUNICIPAL AUTHORITY

default thirty (30) days after receipt of written notice and opportunity to cure, less and except as such lesser time is provided in this **Lease**.

C. Should the **Authority** breach this **Agreement**, **Service Provider** may only recover that proportion of services provided prior to the breach. **Service Provider** may not collect or recover any other or additional damages, losses, or expenses.

18. THIRD PARTY BENEFICIARIES

All parties expressly agree that no third-party beneficiaries, expressly or implicitly, are intended to be or shall be created or acknowledged by this **Agreement**. This **Agreement** is solely for the benefit of the **Service Provider** and the **Authority**, and none of the provisions hereof are intended to benefit any third parties.

19. VENUE AND CHOICE OF LAW

All parties hereto expressly agree that the venue of any litigation relating to or involving this **Agreement** and/or the rights, obligations, duties and covenants therein shall be in the appropriate court (state or federal) located in Oklahoma County, Oklahoma. All parties agree that this **Agreement** shall be interpreted and enforced in accordance with Oklahoma law and all rights of the parties shall be determined in accordance with Oklahoma law.

20. DISPUTE RESOLUTION

Either **Party** may commence the dispute resolution process pursuant to this provision, by providing the other **Party** written notice of the dispute between the **Parties** concerning any term of this **Agreement** or attachment hereto. The notice shall contain:

- (i) a statement setting forth the position of the party giving such notice and a summary of arguments supporting such position and
- (ii) the name and title of **Party** Representative and any other Persons who will accompany the Representative at the meeting at which the parties will attempt to settle the Dispute.

PROFESSIONAL SERVICES AGREEMENT
between
(Service Provider Name)
And
MIDWEST CITY MUNICIPAL AUTHORITY

Within ten (10) days of receipt of the notice, the other **Party** shall respond with

- (i) a statement setting forth the position of the party giving such notice and a summary of arguments supporting such position and
- (ii) the name and title of **Party** Representative and any other Persons who will accompany the Representative at the meeting at which the parties will attempt to settle the Dispute.

The **Parties** shall make good faith attempts to negotiate a settlement between their appointed representatives. If the **Parties** are unable to settle the dispute themselves, the **Parties** shall be required to mediate the dispute, with the **Parties** equally sharing in the cost of said mediation. Mediation shall last at least six (6) hours and be attempted before any litigation shall be filed.

21. VALIDITY

The invalidity or unenforceability of any provision of this **Agreement** shall not affect the validity or enforceability of any other provisions of this **Agreement**, which shall remain in full force and effect.

22. NO WAIVER

The failure or neglect of either of the **Parties** hereto to insist, in any one or more instances, upon the strict performance of any of the terms or conditions of this **Agreement**, or waiver by any party of strict performance of any of the terms or conditions of this **Agreement**, shall not be construed as a waiver or relinquishment in the future of such term or condition, but such term or condition shall continue in full force and effect.

23. NO EXTRA WORK

No claims for extra work, product, services, solution, or deliverables of any kind or nature or character shall be recognized or paid by or be binding upon the **Authority** unless such services, work, product, solution, or deliverable is first requested and approved in writing by the **Authority** through a purchase order.

PROFESSIONAL SERVICES AGREEMENT
between
(Service Provider Name) _____
And
MIDWEST CITY MUNICIPAL AUTHORITY

24. AMENDMENT

This **Agreement** may be amended by mutual agreement of the **Parties**, in writing and signed by both **Parties**. The **Authority** hereby delegates to the Authority Manager all amendments to this **Agreement** for approval and execution, unless the amendment would increase the contracted amount by more than ten percent (10%).

25. EFFECTIVE DATE

The Effective Date of this **Agreement** is the date approved by the **Authority** as the last party hereto.

[REMAINDER OF THIS PAGE INTENTIONALLY LEFT BANK]

PROFESSIONAL SERVICES AGREEMENT
between
(Service Provider Name) _____
And
MIDWEST CITY MUNICIPAL AUTHORITY

IN WITNESS WHEREOF, the parties have caused their properly authorized representatives to execute this **Agreement** on the dates set forth below.

Service Provider: _____ (Name of Service Provider)

By: _____

Name: _____

Title: _____

[REMAINDER OF THIS PAGE INTENTIONALLY LEFT BANK]

PROFESSIONAL SERVICES AGREEMENT
between
(Service Provider Name) _____
And
MIDWEST CITY MUNICIPAL AUTHORITY

APPROVED by the Trustees and **SIGNED** by the Chairman for the Midwest City Municipal Authority this _____ day of _____, 2023.

MIDWEST CITY MUNICIPAL AUTHORITY

MAYOR/CHAIRMAN

SARA HANCOCK, SECRETARY

REVIEWED for form and legality.

DONALD D. MAISCH, AUTHORITY ATTORNEY